

**BESTBERG**

GERMAN QUALITY

AG-18A

602 x 300 x 232 cm

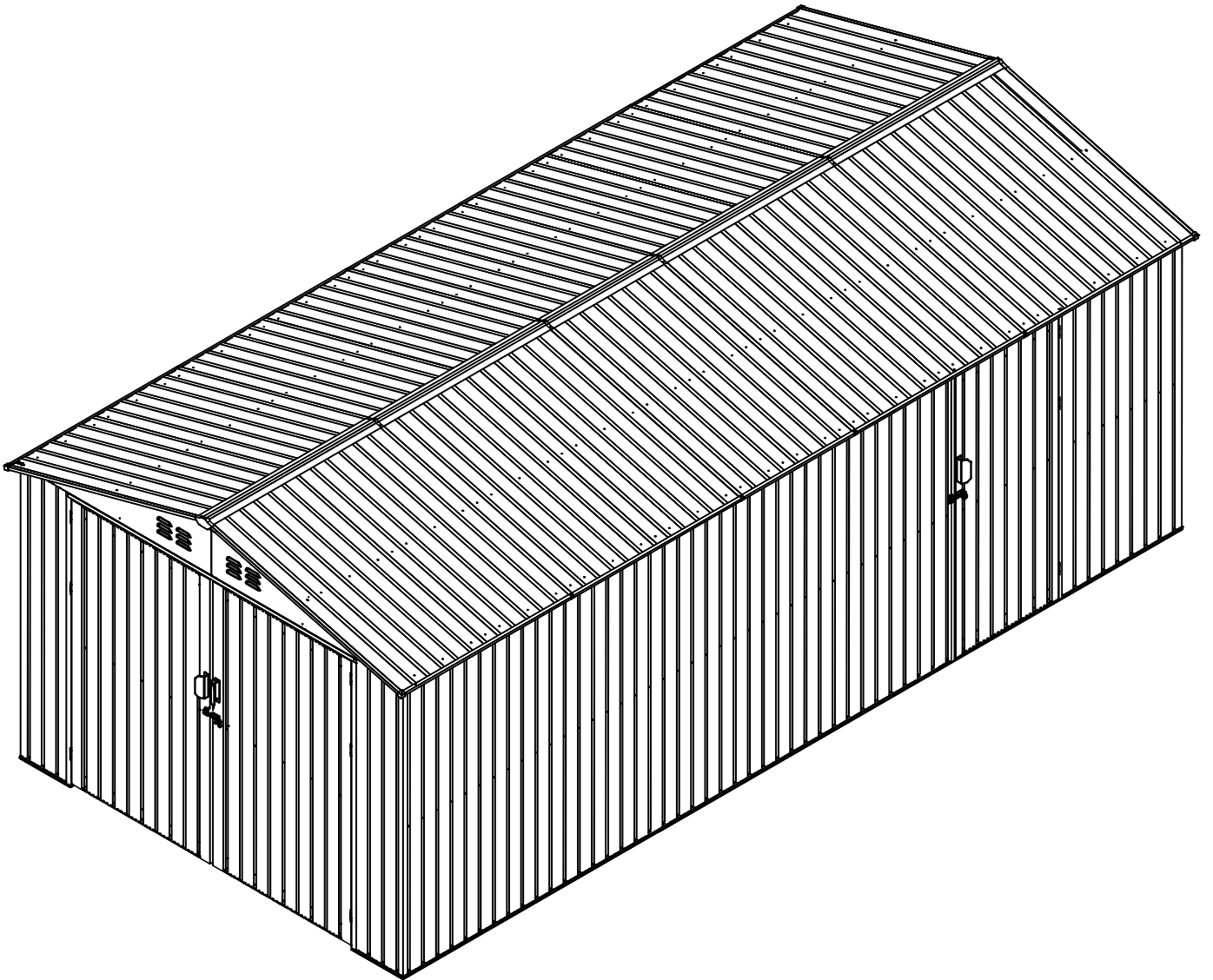

DE Garage für Auto

CZ Garáž pro automobil

SK Garáž pre automobil

PL Garaż na samochód

HU Garázs autónak

RO Garaj auto

Import:

IPRICE RE CARE s.r.o.,

Rybníky IV 326, Zlín 760 01

Czechia

bestberg@bestberg.eu

Made in China

DE

BEVOR SIE BEGINNEN

Benutzerhandbuch

Vor der Installation sollten Sie Ihre örtliche Behörde kontaktieren, um festzustellen, ob eine Baugenehmigung erforderlich ist. Lesen und verstehen Sie dieses Handbuch sorgfältig – wichtige Informationen und hilfreiche Tipps erleichtern den Aufbau und machen ihn angenehmer.

Montageanleitung

Die Anweisungen in diesem Handbuch beziehen sich auf Ihr spezielles Modell. Lesen Sie alle Schritte vollständig, bevor Sie beginnen. Folgen Sie während der Montage sorgfältig der Schrittfolge für ein korrektes Ergebnis.

Bitte beachten Sie: Für die vollständige Montage werden zwei Personen und etwa ein ganzer Arbeitstag benötigt.

Teilekontrolle

Überprüfen Sie, ob alle erforderlichen Teile vorhanden sind.

Sortieren Sie den Inhalt des Kartons anhand der Teilenummern und vergleichen Sie ihn mit der Stückliste.

Machen Sie sich mit allen Schrauben, Muttern und Befestigungen vertraut – zusätzliche Teile sind als Reserve beigelegt.

PLANUNG

Wetterbedingungen

Wählen Sie einen trockenen und windstillen Tag für die Installation.

Bauen Sie die Garage nicht bei Wind auf – es besteht Risiko von beschädigten Paneelen oder Verletzungen.

Achten Sie auf nassen oder schlammigen Untergrund.

Teamarbeit

Montagearbeiten sind deutlich einfacher, wenn zwei oder mehr Personen zusammenarbeiten. Eine Person kann Teile oder Paneele positionieren, während die andere die Befestigungselemente und Werkzeuge handhabt.

Standortwahl

Vermeiden Sie überhängende Bäume – fallende Blätter erfordern regelmäßige Reinigung, herabfallende Äste sind gefährlich.

Kleine Sträucher oder Zäune können als Windschutz dienen.

Vorbereitung des Untergrunds

Der Untergrund muss rundum waagrecht sein – prüfen Sie dies mit einer Wasserwaage.

Die Basis kann aus behandeltem Holz oder Beton bestehen, um Feuchtigkeit vom Inneren fernzuhalten.

Die Garage ist nicht dafür ausgelegt, direkt auf Rasen aufgebaut zu werden – bei Regen wird der Boden matschig.

Eine Betonplatte sollte leicht nach außen geneigt sein, um Wasser abfließen zu lassen.

Beton oder Zement müssen vollständig trocknen, bevor die Montage beginnt.

Ziegel oder Betonblöcke können ebenfalls als Fundament verwendet werden.

Der Rahmen muss mit geeigneten Schrauben oder Ankern sicher am Fundament befestigt werden.

WICHTIGE HINWEISE

Arbeiten Sie mit einer zweiten Person – viele Schritte sind zu zweit deutlich einfacher. Einige Montageschritte erfordern das gemeinsame Anheben größerer Teile.

Nehmen Sie sich ausreichend Zeit – bei Eile passieren häufig Fehler, die später korrigiert werden müssen. Wenn Sie noch nie eine Garage aufgebaut haben, kann dies den ganzen Tag dauern.

Halten Sie das richtige Werkzeug bereit.

Legen Sie alle Teile aus und überprüfen Sie die Vollständigkeit, bevor Sie beginnen. Verwenden Sie Tücher oder Folien, um Kratzer zu vermeiden.

Ziehen Sie alle Muttern sorgfältig fest und kontrollieren Sie, ob der Rahmen rechtwinklig und senkrecht steht (Wasserwaage verwenden).

CZ

PŘED ZAHÁJENÍM

Uživatelský manuál

Před montáží se informujte na místním úřadě, zda není vyžadováno stavební povolení. Pečlivě si přečtěte tento návod – důležité informace a tipy vám montáž výrazně usnadní.

Montážní pokyny

Pokyny v manuálu odpovídají vašemu modelu. Před zahájením si je celé přečtěte a postupujte pečlivě krok za krokem.

Upozornění: K úplné montáži jsou potřeba dvě osoby a přibližně jeden celý den.

Kontrola dílů

Zkontrolujte, zda máte všechny díly.

Roztřídte obsah balení podle čísel součástí.

Seznamte se se spojovacím materiálem – přiloženy jsou i náhradní kusy.

PLÁNOVÁNÍ

Počasí

Zvolte suchý a klidný den.

Garáž nesestavujte za větru – hrozí poškození panelů nebo zranění.

Pozor na mokrou a rozbahněnou zem.

Týmová práce

Montáž je o mnoho jednodušší ve dvou osobách.

Jeden člověk může držet a polohovat díly, druhý pracuje s nářadím.

Výběr místa

Vyhnete se stromům přímo nad stavbou – listí zvyšuje nutnost údržby a větve mohou být nebezpečné. Keře nebo plot mohou fungovat jako závětrří.

Příprava podkladu

Podklad musí být rovný – ověřte vodováhou.

Základ může být z impregnovaného dřeva nebo betonu, aby dovnitř nevnikala vlhkost.

Garáž není určena k montáži přímo na trávník.

Betonová deska musí být mírně vyspádovaná směrem ke krajům.

Před montáží nechte beton zcela vytvrdnout.

Použit lze také cihly nebo betonové bloky.

Rám musí být pevně připevněn k základně pomocí vhodných šroubů nebo kotev.

DŮLEŽITÉ POZNÁMKY

Najděte si pomocníka – řada kroků je mnohem jednodušší ve dvou.

Nespěchejte – chyby při montáži vznikají převážně kvůli spěchu.

Připravte si vhodné nářadí.

Používejte doporučené ochranné pomůcky.

Před zahájením montáže rozložte všechny díly a zkontrolujte jejich kompletnost.

Utáhněte všechny matice a ověřte, že rám je pravoúhlý a stojí rovně (vodováhou).

SK

PRED ZAČATÍM

Užívateľský manuál

Pred montážou si overte na miestnom úrade, či nie je potrebné stavebné povolenie. Dôkladne si prečítajte tento návod – pomôže vám zostaviť garáž jednoduchšie a bezpečnejšie.

Montážne pokyny

Pokyny sa vzťahujú na váš model. Prečítajte si ich pred začiatkom montáže a postupujte podľa uvedených krokov.

Upozornenie: Na kompletnú montáž sú potrebné dve osoby a približne celý deň.

Kontrola dielov

Skontrolujte všetky súčiastky podľa zoznamu dielov.

Roztriedte balenie podľa čísel.

Zoznámte sa so spojovacím materiálom – v balení sú aj rezervné kusy.

PLÁNOVANIE

Počasié

Vyberte suchý a bezveterný deň.

Garáž nemontujte vo vetre, hrozí poškodenie panelov alebo úraz.

Dávajte pozor na mokrú alebo blatistú pôdu.

Tímová práca

Montáž je omnoho jednoduchšia, ak ju vykonávajú dvaja ľudia.

Výber miesta

Vyhýbajte sa stromom s previsnutými konármi.

Kríky alebo plot môžu slúžiť ako prirodzené závetrie.

Príprava podložia

Podklad musí byť rovný – skontrolujte vodováhou.

Základ môže byť z dreva alebo betónu, aby sa zabránilo vlhkosti.

Garáž nie je určená na montáž priamo na trávnik.

Betónová doska musí byť vypsávaná smerom ku krajom.

Betón musí pred montážou úplne vytvrdnúť.

Použiť možno aj tehly alebo bloky.

Rám musí byť pevne priskrutkovaný ku základni vhodnými skrutkami alebo kotvami.

DÔLEŽITÉ POZNÁMKY

Požiadajte o pomoc – manipulácia s dielmi je omnoho jednoduchšia vo dvojici.

Pracujte bez zhonu – pri rýchlej montáži dochádza k chybám.

Majte pripravené správne náradie.

Používajte odporúčanú ochrannú výbavu.

Rozložte a skontrolujte všetky diely pred začiatkom práce.

Skontrolujte pravouhlosť a zvislosť rámu pomocou vodováhy.

PL PRZED ROZPOCZĘCIEM

Instrukcja użytkownika

Przed rozpoczęciem montażu sprawdź w lokalnym urzędzie, czy wymagane jest pozwolenie na budowę. Dokładnie przeczytaj tę instrukcję — zawarte informacje ułatwią montaż.

Instrukcje montażu

Instrukcje zawierają wszystkie informacje dotyczące Twojego modelu. Przeczytaj cały dokument przed rozpoczęciem.

Uwaga: Do montażu potrzeba dwóch osób i około jednego pełnego dnia pracy.

Części

Sprawdź kompletność wszystkich elementów.

Posegreguj zawartość kartonu według numerów.

Zapoznaj się z elementami mocującymi — zapasowe części są dołączone.

ZAPLANUJ PRACĘ

Pogoda

Wybierz suchy i bezwietrzny dzień.

NIE montuj garażu podczas wietrznej pogody.

Uważaj na mokry lub błotnisty teren.

Praca zespołowa

Najlepiej pracować w dwie osoby — jedna ustawia elementy, druga operuje narzędziami.

Wybór miejsca

Unikaj drzew znajdujących się nad konstrukcją.

Krzewy i ogrodzenia mogą działać jako osłona przeciwwiatrowa.

Przygotowanie podłoża

Podłoże musi być wypoziomowane.

Fundament może być wykonany z impregnowanego drewna lub betonu, aby zapobiec wnikaniu wilgoci.

Garaż nie jest przeznaczony do montażu na trawie.

Płyta betonowa powinna być nachylona ku krawężnikom.

Beton musi całkowicie wyschnąć.

Można wykorzystać bloczki lub cegły.

Rama musi być solidnie przymocowana do podstawy za pomocą odpowiednich śrub lub kotew.

WAŻNE UWAGI

Pracuj z drugą osobą — wiele czynności wymaga współpracy.

Zaplanuj odpowiednią ilość czasu — pośpiech prowadzi do błędów.

Przygotuj właściwe narzędzia i odzież ochronną.

Rozłóż elementy i sprawdź ich kompletność.

Sprawdź pion i poziom konstrukcji poziomą.

HU A KEZDÉS ELŐTT

Használati útmutató

A telepítés előtt érdeklődjön a helyi hatóságoknál, hogy szükséges-e építési engedély. Olvassa el figyelmesen az útmutatót.

Összeszerelési útmutató

A kézikönyv tartalmaz minden lényeges információt a modellhez. Olvassa el az összes lépést előre. Figyelem: A szereléshez két személy és körülbelül egy teljes nap szükséges.

Alkatrészek

Ellenőrizze az összes alkatrészt.
Rendezze a csomag tartalmát cikkszám szerint.
Ismerkedjen meg a rögzítőelemekkel.

TERVEZÉS

Időjárás

Válasszon száraz, szélcsendes napot.
NE szerelje össze a garázst szeles időben.
Kerülje a nedves, sáros talajt.

Csapatmunka

A szerelés két fővel sokkal könnyebb.

Hely kiválasztása

Kerülje a lelógó fákat.
Bokrok vagy kerítések szélfogóként szolgálhatnak.

A helyszín előkészítése

A talajnak teljesen egyenesnek kell lennie.
Az alap készülhet kezelt fából vagy betonból.
A garázst nem szabad közvetlenül a fűre telepíteni.
A betonlap legyen enyhén lejtős a szélek felé.
Hagyja a betont megszáradni.
Téglák vagy betonblokkok is használhatók.
A keretet megfelelő csavarokkal vagy rögzítőelemekkel biztonságosan kell rögzíteni.

FONTOS MEGJEGYZÉSEK

Kérjen segítséget — sok feladat két emberrel könnyebb.
Ne kapkodjon — a hibák többsége sietségből adódik.
Használjon megfelelő szerszámokat.
Viseljen védőfelszerelést.
Ellenőrizze az alkatrészek teljességét.
Ellenőrizze, hogy a keret derékszögű és függőleges (vízmértékkel).

RO

ÎNAINTE DE A ÎNCEPE

Manualul utilizatorului

Înainte de instalare, verificați dacă este necesară o autorizație de construcție. Citiți cu atenție acest manual.

Instrucțiuni de asamblare

Instrucțiunile se referă la modelul dumneavoastră. Citiți toate etapele înainte de începere. Atenție: Montajul complet necesită două persoane și aproximativ o zi întreagă.

Piese

Verificați toate componentele.
Sortați piesele după număr.
Familiarizați-vă cu elementele de fixare.

PLANIFICARE

Vremea

Alegeți o zi uscată și fără vânt.
NU montați garajul în condiții de vânt puternic.
Evitați solul noroiOS.

Lucru în echipă

Două persoane pot monta structura mult mai ușor.

Alegerea amplasamentului











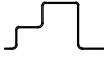
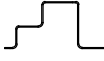
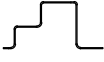
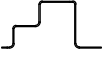
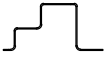
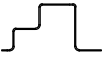





Evitați copacii cu ramuri deasupra.
Arbuștii sau gardurile pot acționa ca paravânt.



















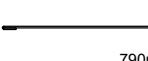

Pregătirea terenului







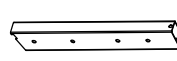

Baza trebuie să fie nivelată.
Fundatia poate fi realizată din lemn tratat sau beton.
Garajul nu este destinat instalării direct pe gazon.
Placa de beton trebuie să aibă o ușoară înclinație spre margini.
Lăsați betonul să se usuce complet.
Se pot folosi blocuri sau cărămizi.
Cadrul trebuie fixat în siguranță de bază folosind șuruburi sau ancore adecvate.

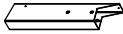





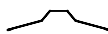
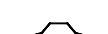

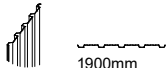
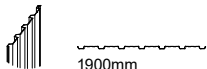
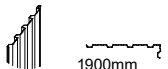
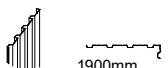
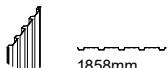
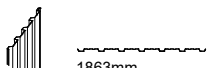
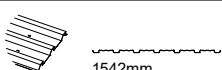
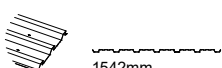
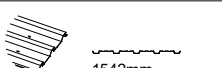
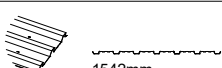





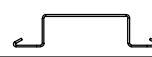





NOTE IMPORTANTE













Lucrați cu o a doua persoană — multe etape necesită ridicarea sau ținerea elementelor.
Acordați timp suficient — graba duce la greșeli.
Utilizați unelte adecvate și echipament de protecție.
Verificați componentele înainte de montaj.
Verificați verticalitatea și alinierea cadrului (nivela).

Part No.	Part	Qty
1	 1929mm	4
2	 2036mm	2
3L	 387mm	1
3R	 387mm	1
4L	 1490mm	1
4R	 1490mm	1
5L	 1914mm	1
5R	 1914mm	1
7	 2194mm	1
7L	 369mm	1
7R	 369mm	1
6L	 1440mm	1
6R	 1440mm	1
10L	 1439mm	1
10R	 1439mm	1
12	 1994mm	4
13	 1912mm	4
14	 1912mm	4
12L	 1871mm	1
12R	 1871mm	1
22	 1956mm	2
24	 993mm	1

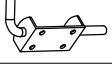
Part No.	Part	Qty
23L	 903mm	1
23R	 903mm	1
B1	 196mm	2
B2	 196mm	2
B3	 295mm	4
25L	 1900mm	1
25R	 1900mm	1
8	 2083mm	2
8L	 1939.5mm	2
8R	 1939.5mm	2
J4	 2	
35	 790mm	1
A1	 230mm	8
A2	 233mm	4
A9	 233mm	4
A4	 285mm	4
A5	 90mm	8
A10	 2194mm	1
J3	 137mm	2
J1	 142mm	4
J8	 180mm	4
A6	 1478.4mm	4

Part No.	Part	Qty
A7	 1860mm	2
A8	 1913mm	4
15	 1304mm	4
15-1	 1304mm	2
15-2	 1304mm	2
15-3	 876mm	2
17	 1542mm	2
18	 1542mm	2
19	 876mm	1
20	 1304mm	4
21L	 1900mm	2
21R	 1900mm	2
P2	 1900mm	6
P3	 1900mm	16
P4	 1900mm	2
P10	 1900mm	2
D1	 1858mm	4
D2	 1863mm	1
P5	 1542mm	2
P6	 1542mm	2
P7	 1542mm	4
P8	 1542mm	12

Part No.	Part	Qty
29	 1864mm	4
29-1	 1864mm	4
30	 1864mm	4
36	 1864mm	1
37	 867mm	1
38	 867mm	1
39	 775mm	1
40	 1864mm	1
41	 1864mm	1
42	 776mm	2
43	 1043mm	4
44	 1859mm	1
45	 1859mm	1
46	 1859mm	1
47	 1859mm	1
48	 1162mm	2
49	 1162mm	2
50	 1042mm	2
B6	 1864mm	9
Ø2.4	 1864mm	1
Ø5	 1864mm	1

Part No.	Part	Qty
F1		960
F2		177
F3		42
S2		550
S3		792
F5		40
F4		16
H2		2
GC		4
GE		2
B5		3
H1		2
J5		1
J6		1

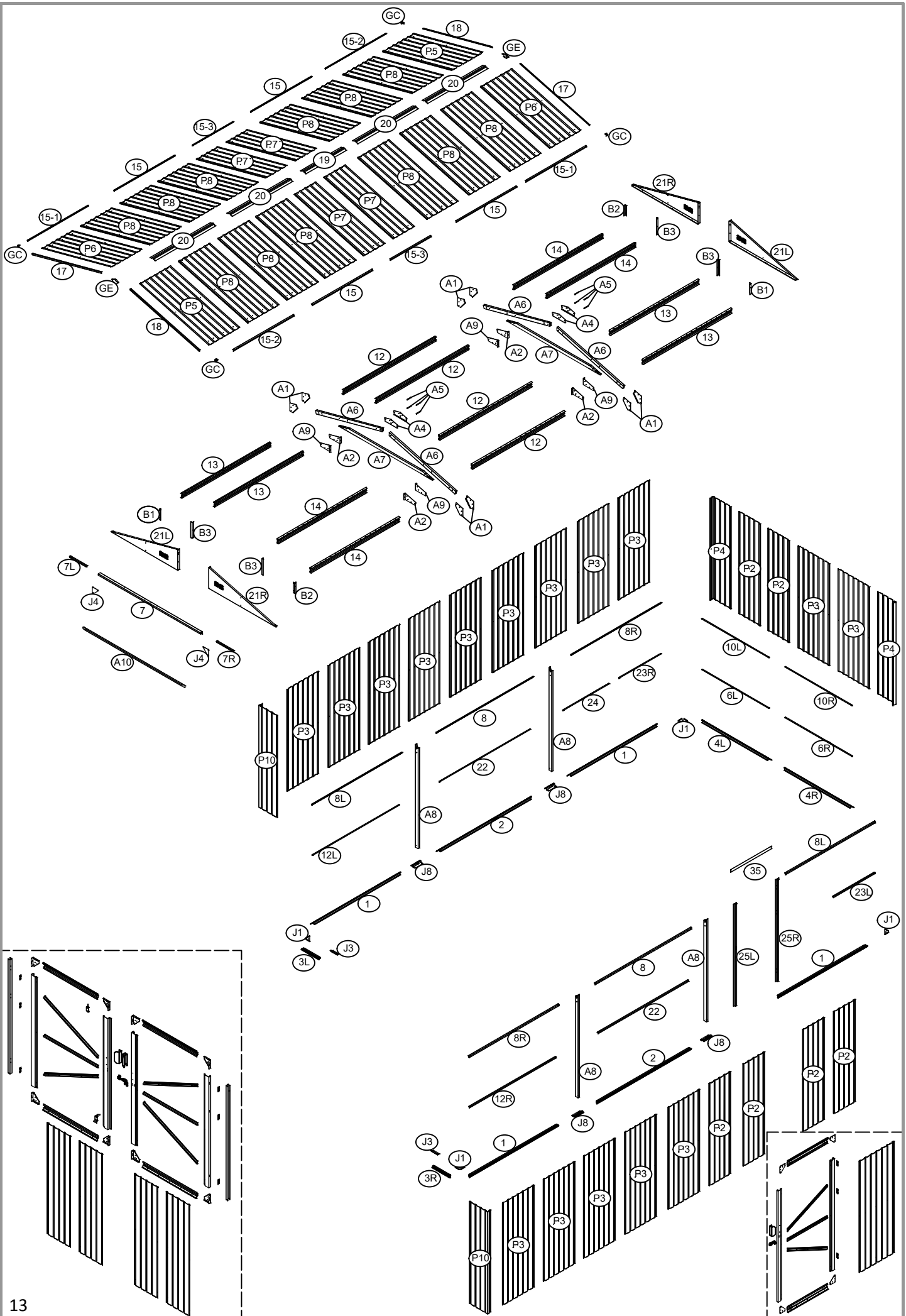

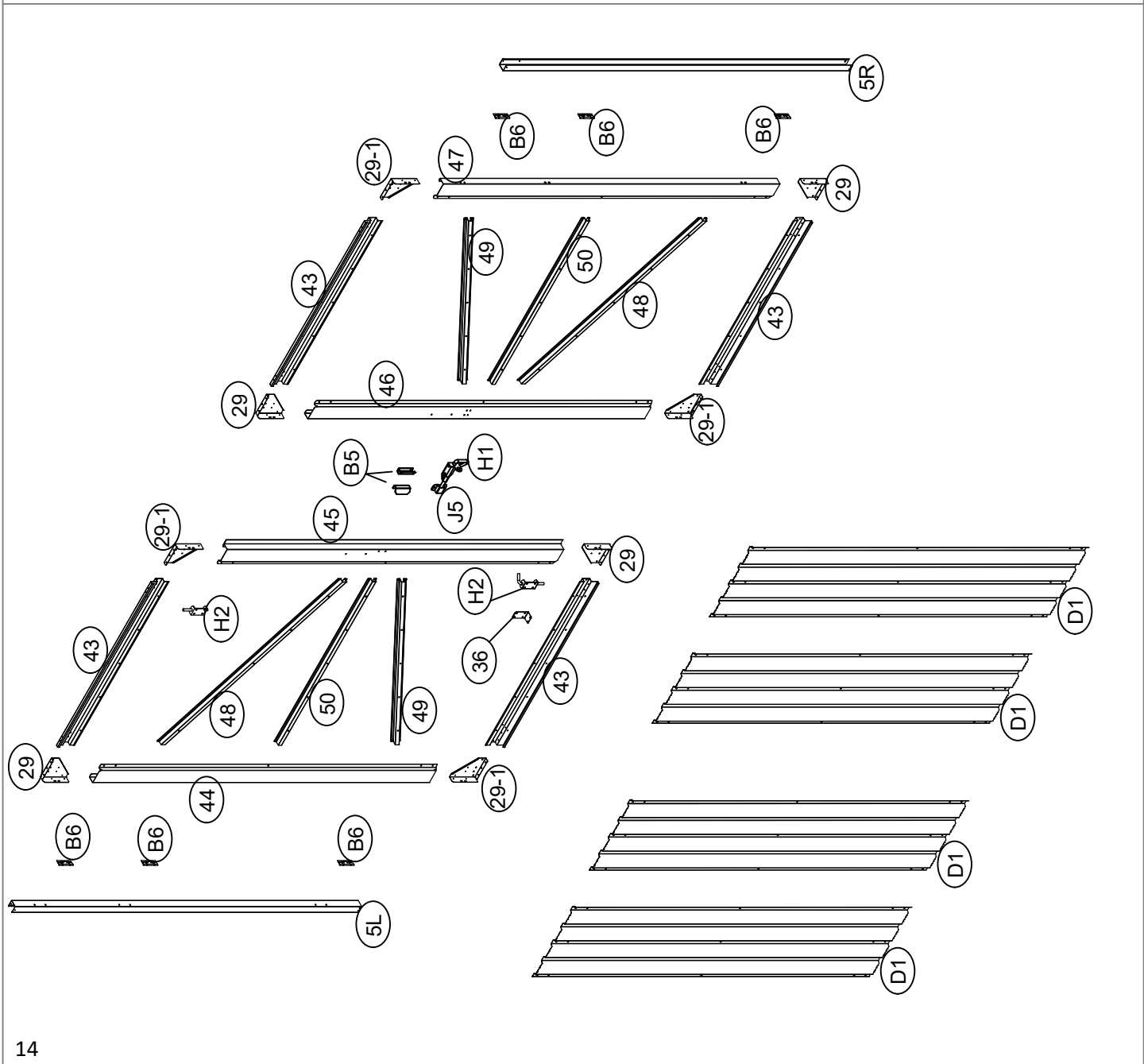
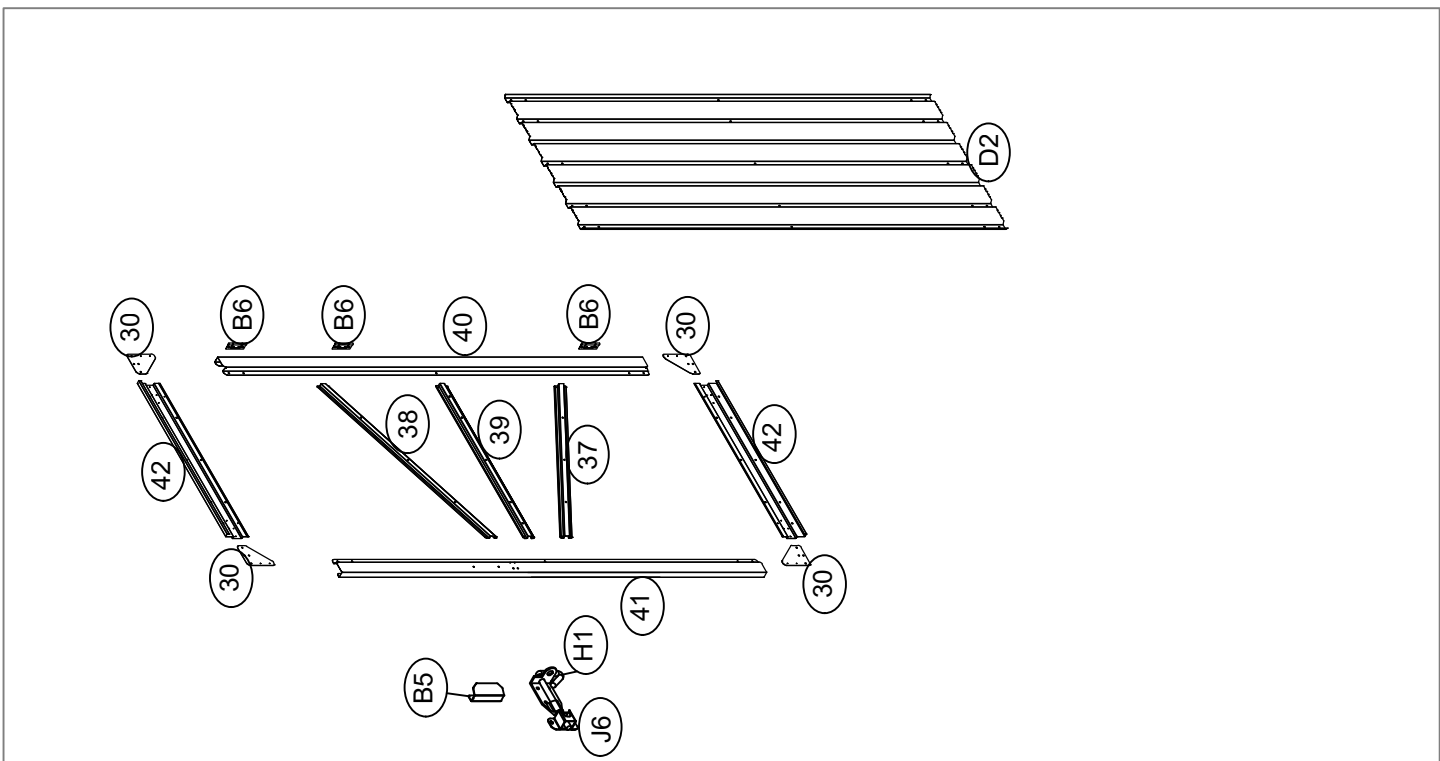



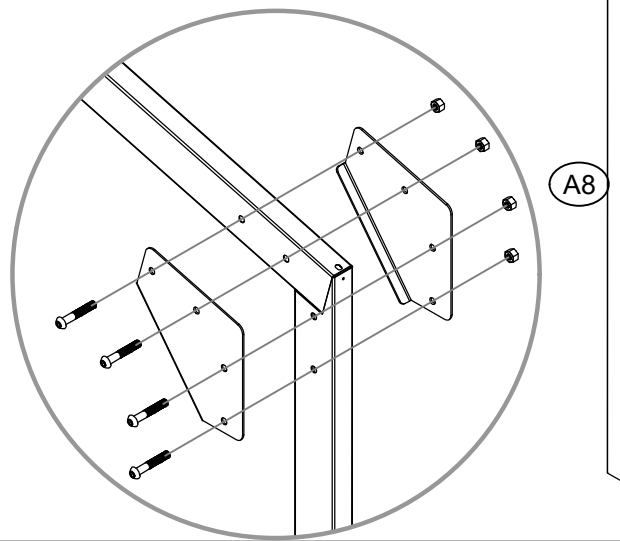
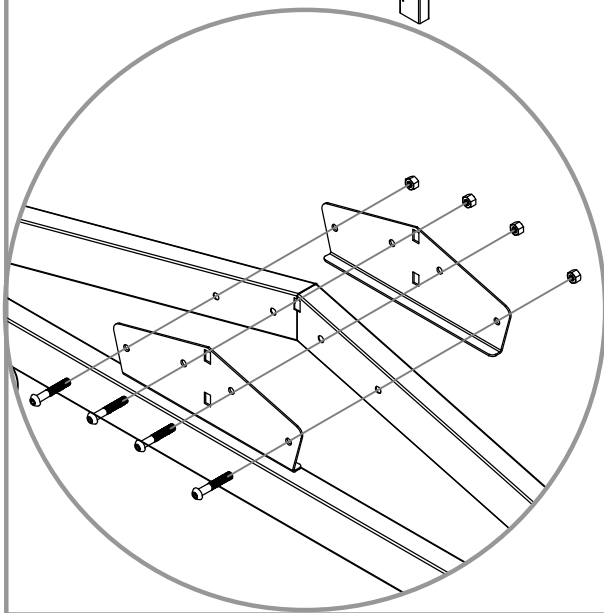
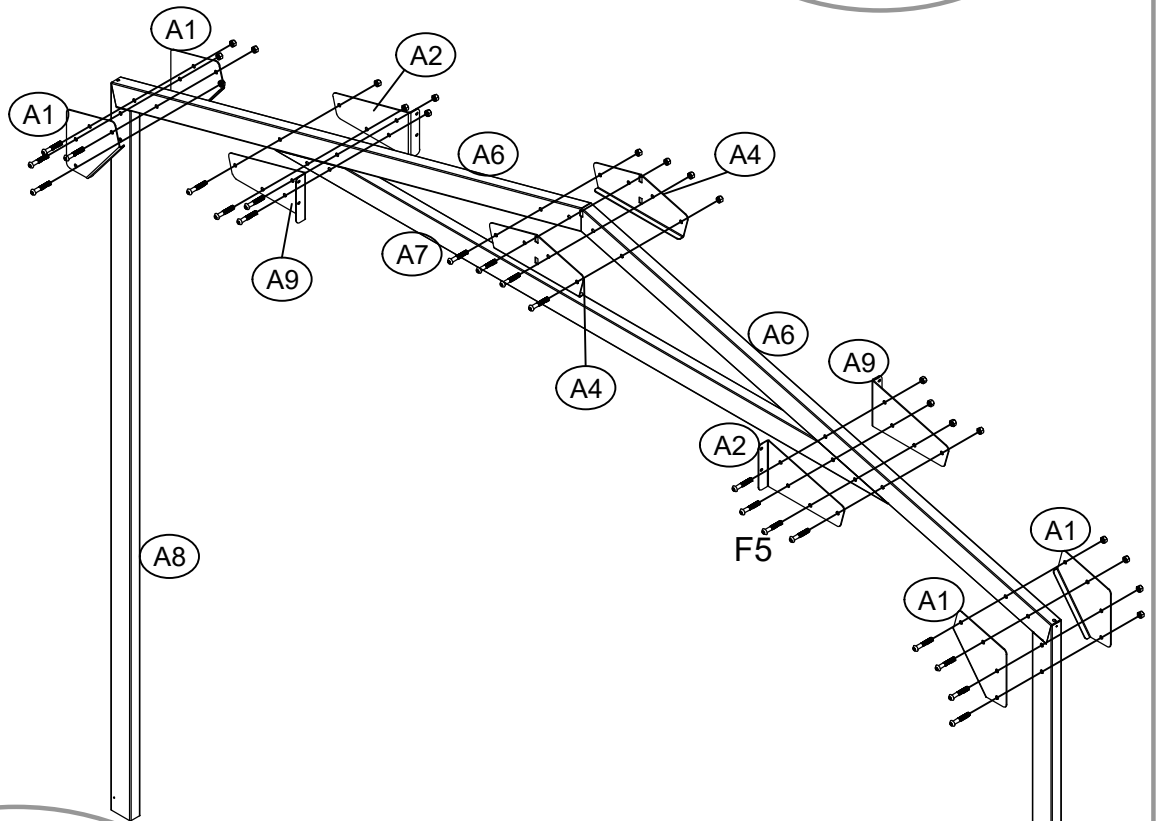
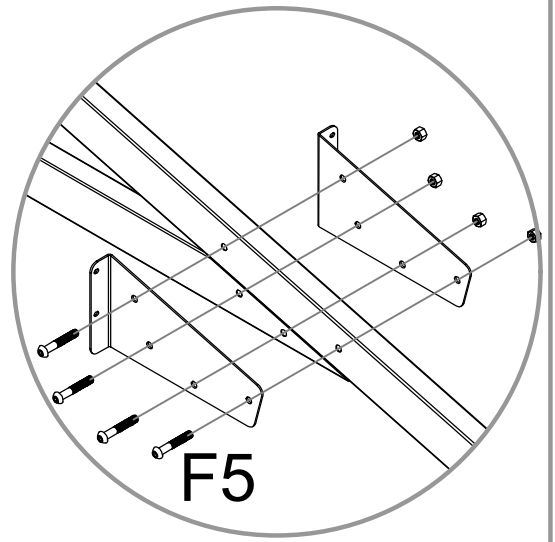

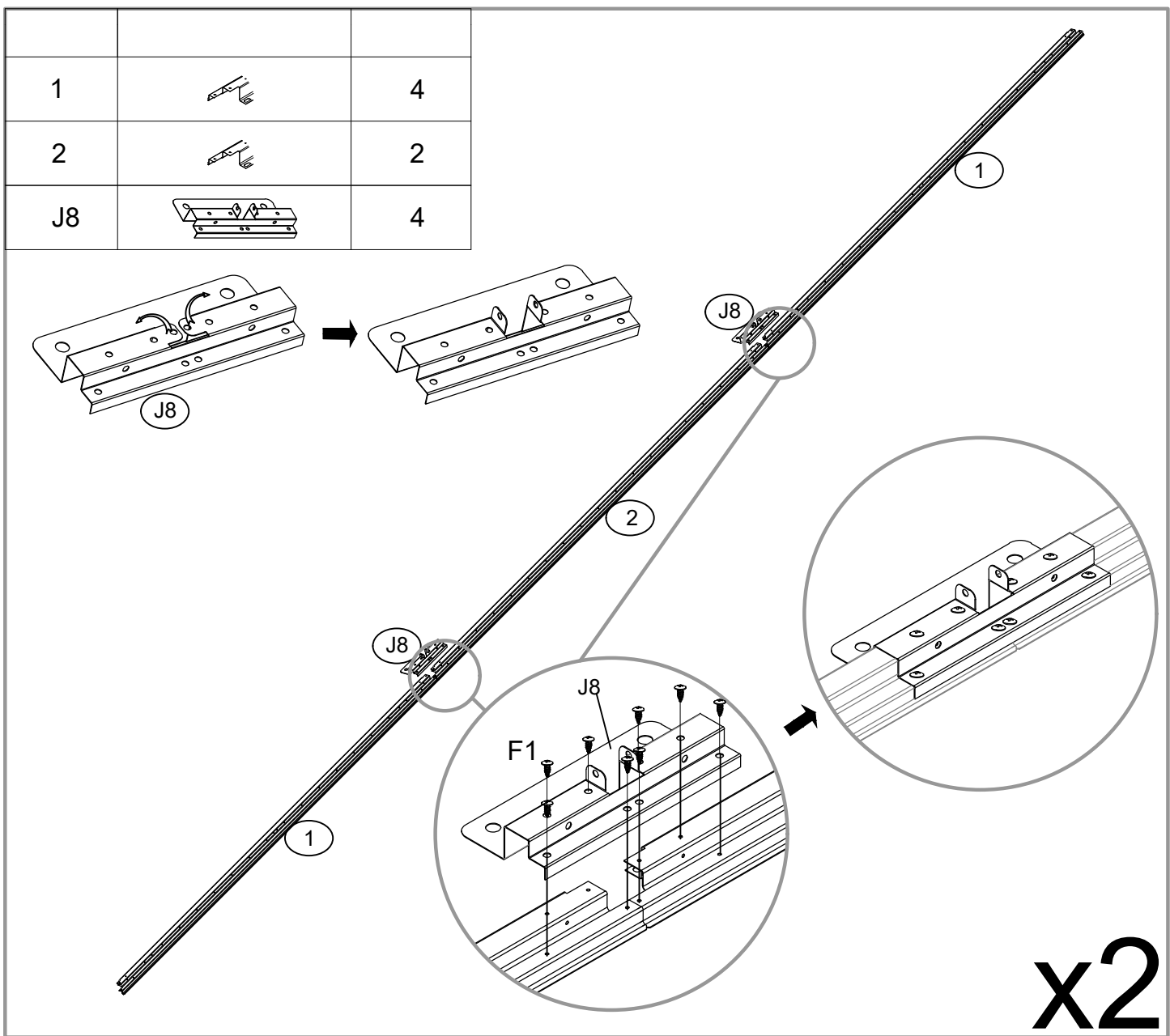
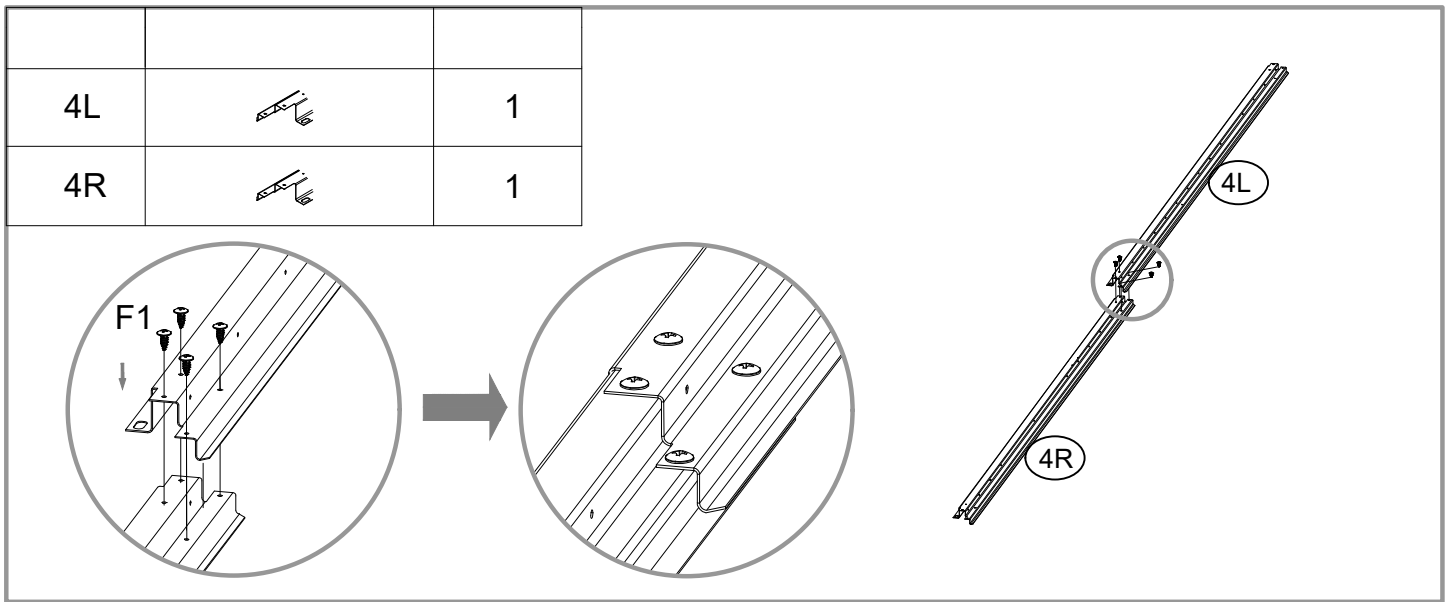
A1		8
A2		4
A9		4
A4		4
A6		4
A7		2
A8		4





3L		1
3R		1
J3		2
J1		4

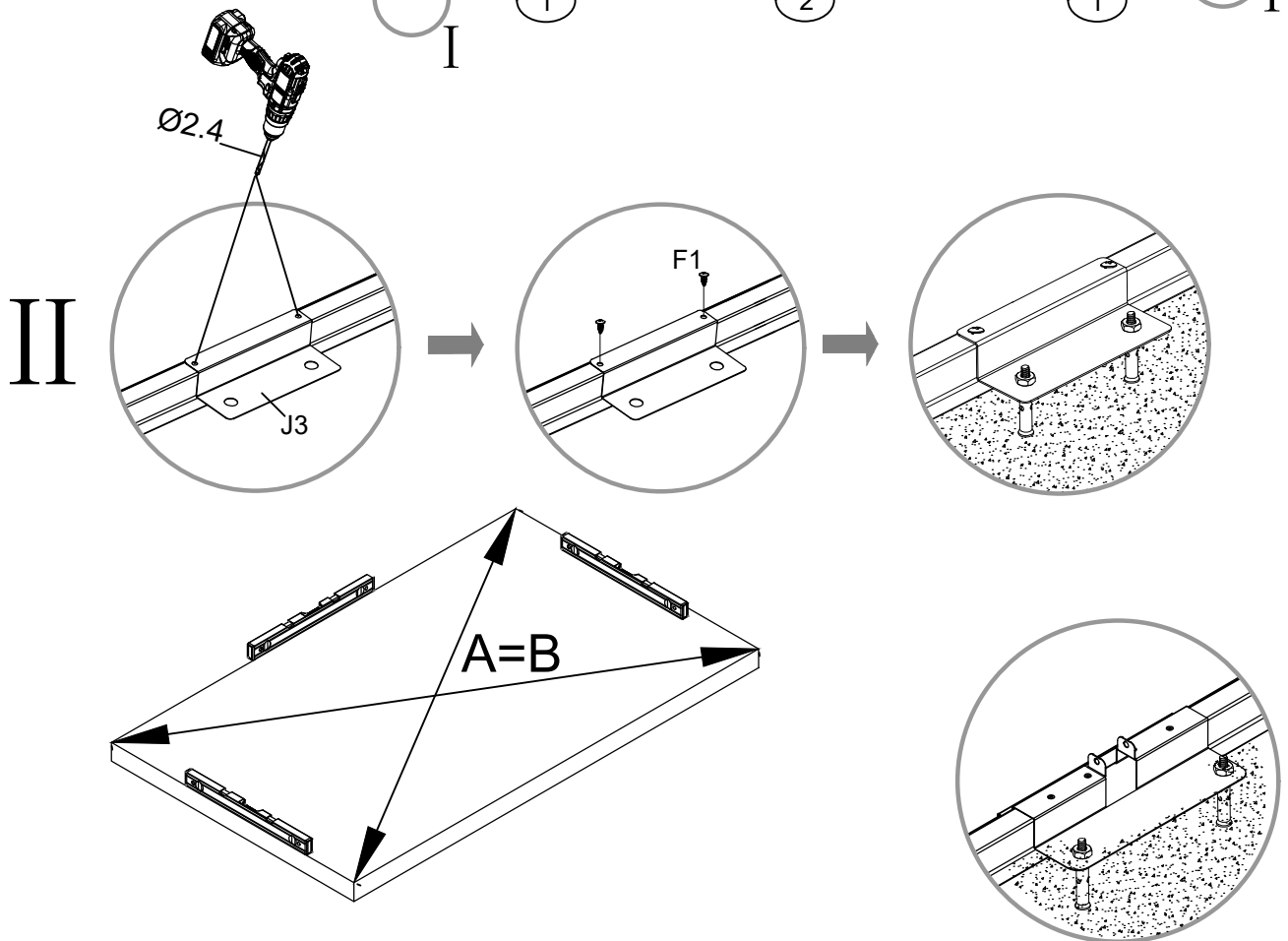
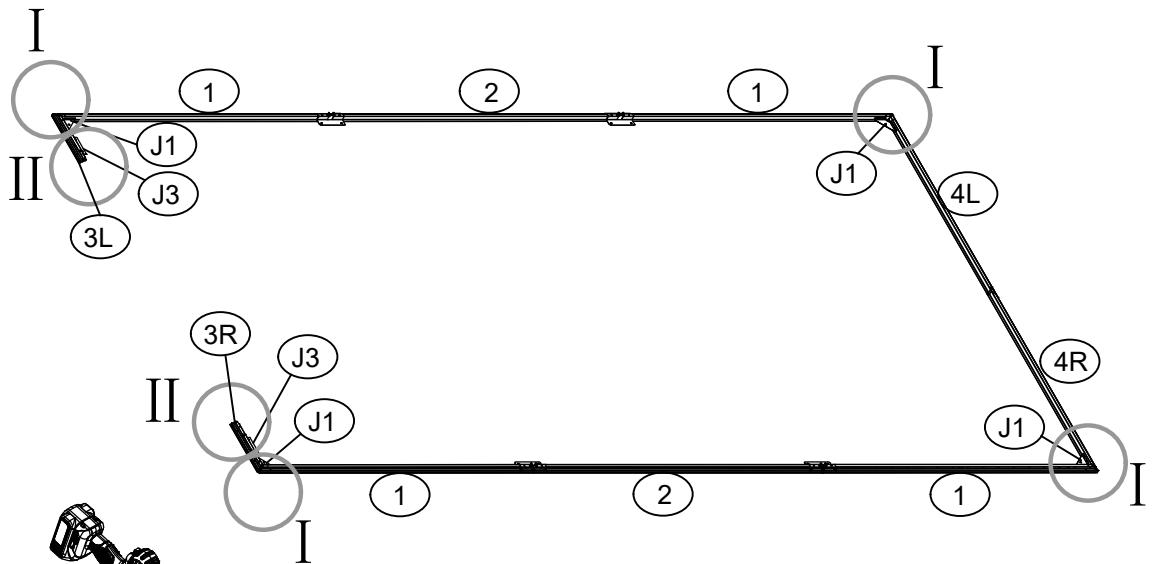
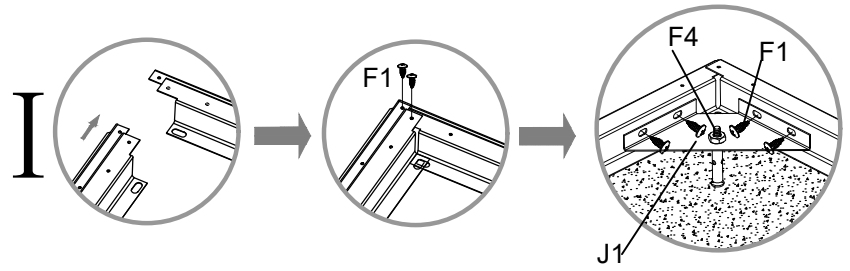

DE Wenn die diagonalen Maße übereinstimmen und der Bodenrahmen sowohl rechtwinklig als auch waagrecht ist, passen alle Bohrlöcher korrekt zueinander.

CZ Pokud jsou diagonální rozměry shodné a podlahový rám je zároveň pravouhlý i vodorovný, všechny montážní otvory se správně srovnají.

SK Ak sú diagonálne rozmery rovnaké a podlahový rám je zároveň pravouhlý aj vodorovný, všetky montážne otvory sa správne zarovnajú.

PL Jeśli pomiary przekątnych są równe, a rama podłogowa jest jednocześnie pod właściwym kątem i wypoziomowana, wszystkie otwory montażowe będą się prawidłowo pokrywać.

HU Ha az átlóméresék megegyeznek, és a padlókeret egyszerre derékszögű és vízszintes, akkor minden furat pontosan illeszkedni fog.

RO Dacă măsurătorile pe diagonală sunt egale, iar cadrul podelei este atât drept, cât și perfect nivelat, toate găurile de montaj se vor alinia corect.

DE Die Tür wird auf der linken Seite installiert.
CZ Dveře jsou instalovány vlevo.
SK Dvere sú nainštalované naľavo.
PL Drzwi są montowane po lewej stronie.
HU Az ajtó a bal oldalra kell felszerelni.
RO Ușa este instalată pe partea stângă.

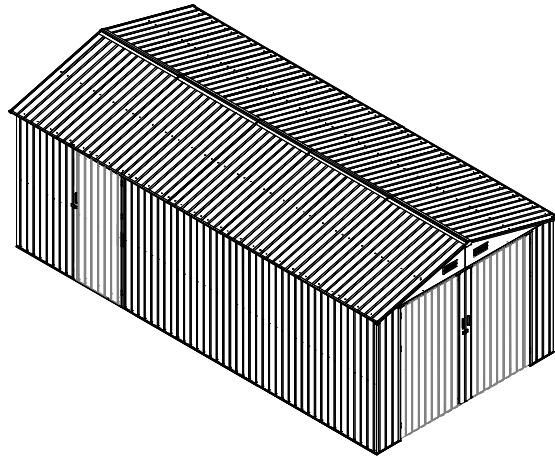

P3		1
P4		1
23L		1
6R		1

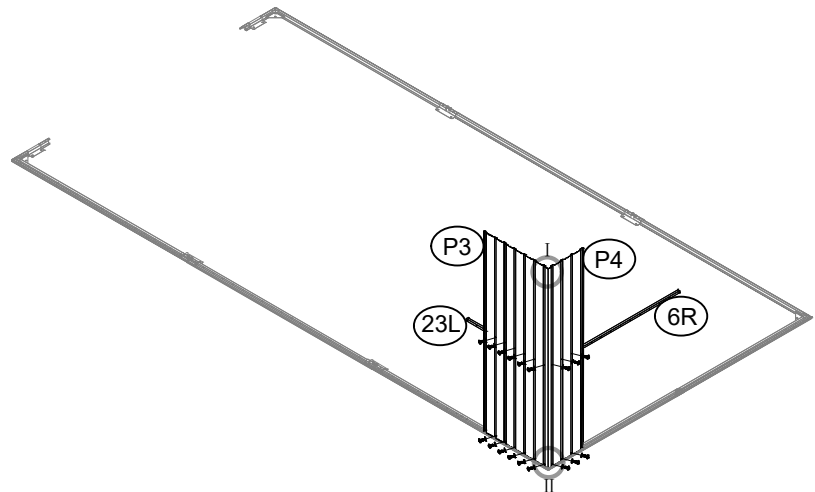
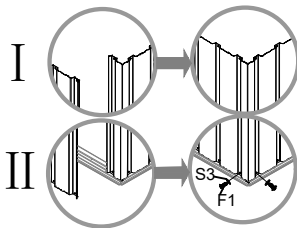

P2		1
P4		1
23R		1
6L		1

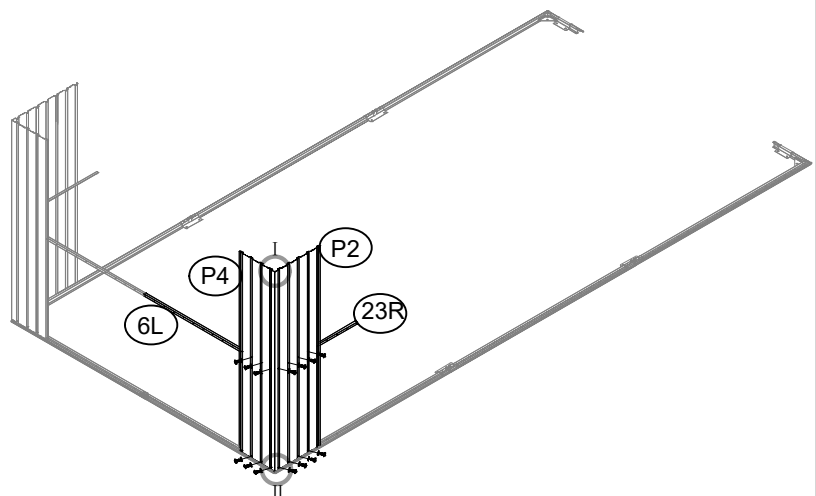
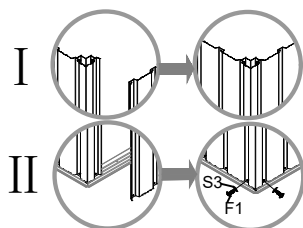

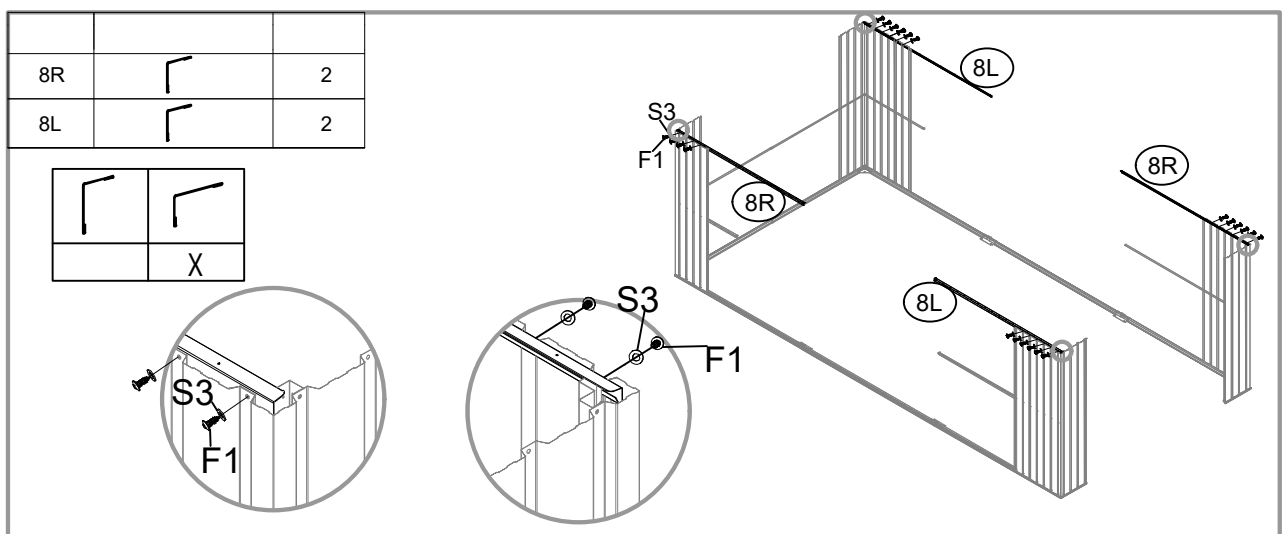
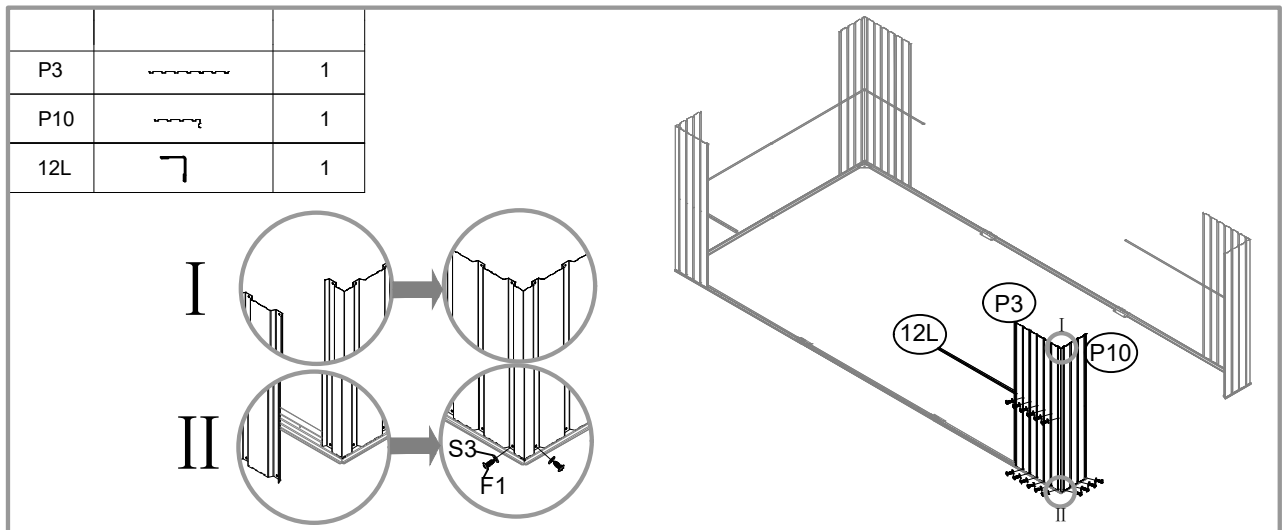
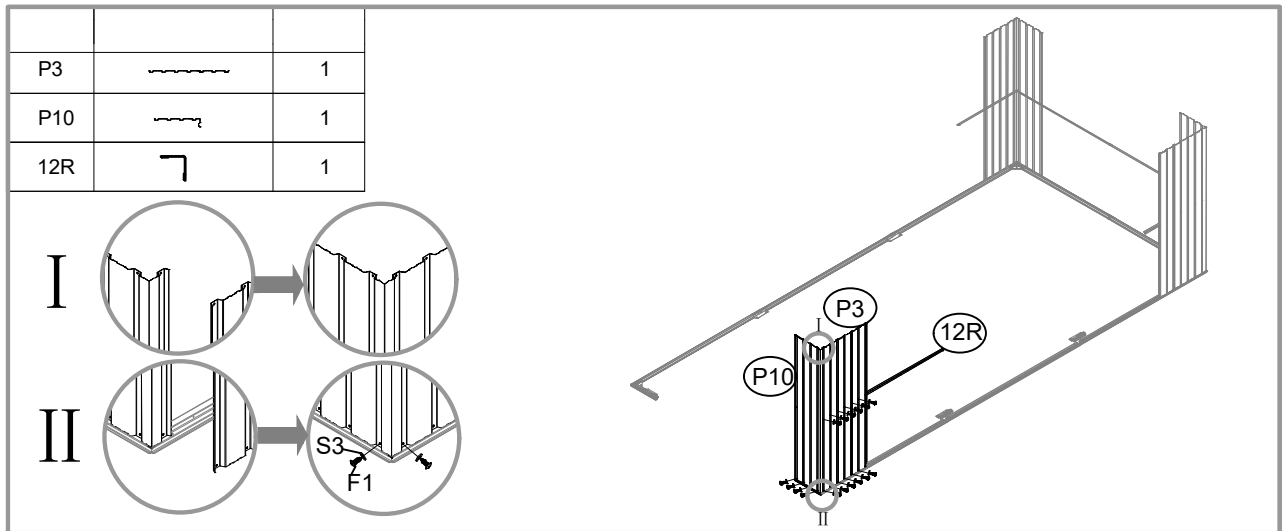

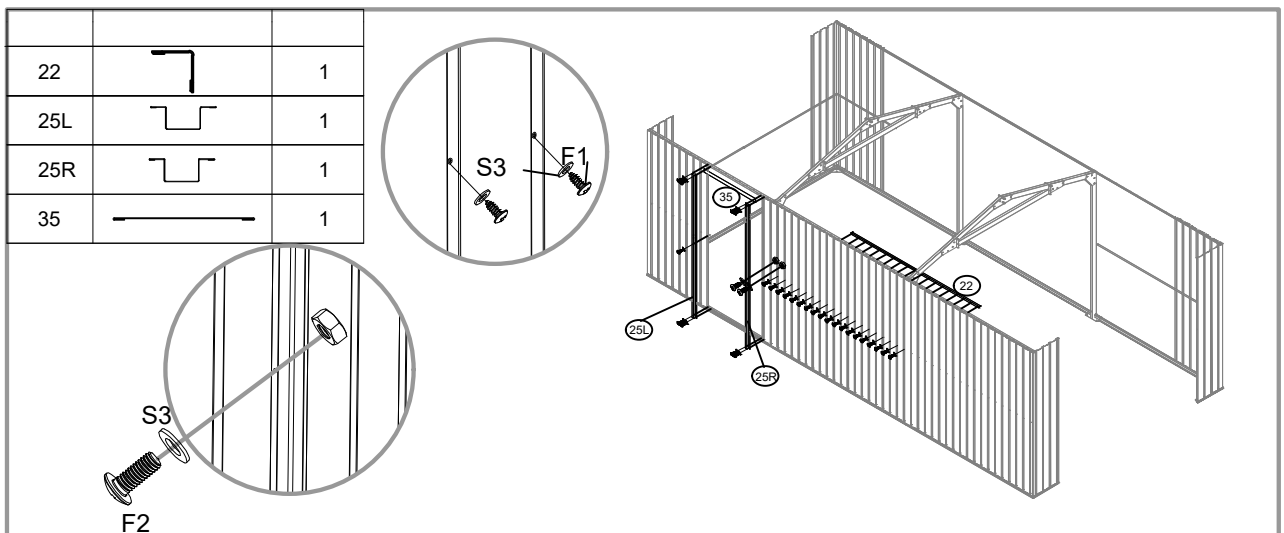
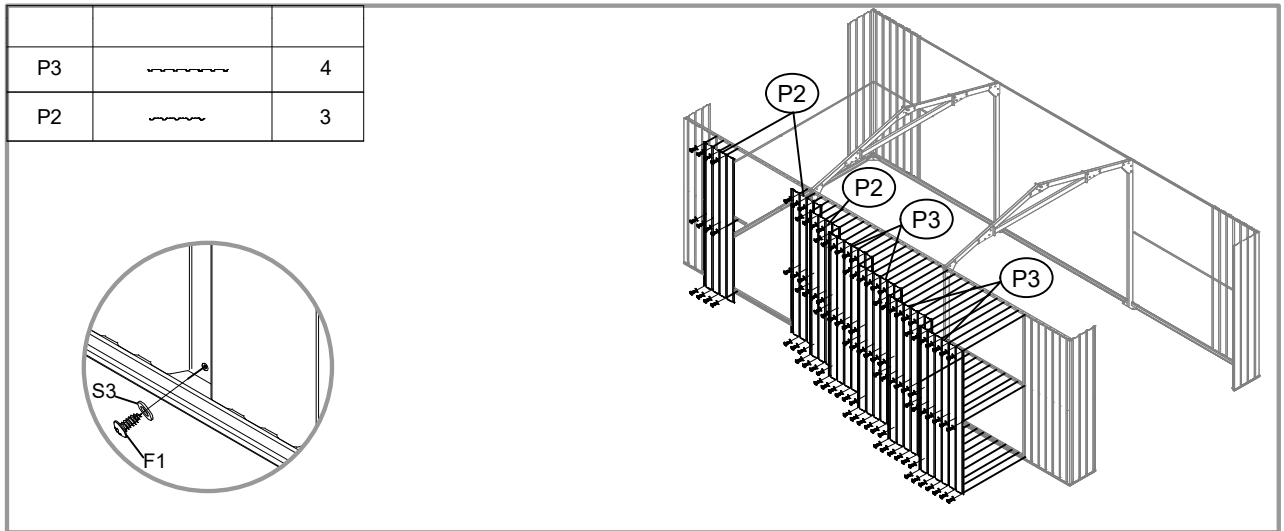
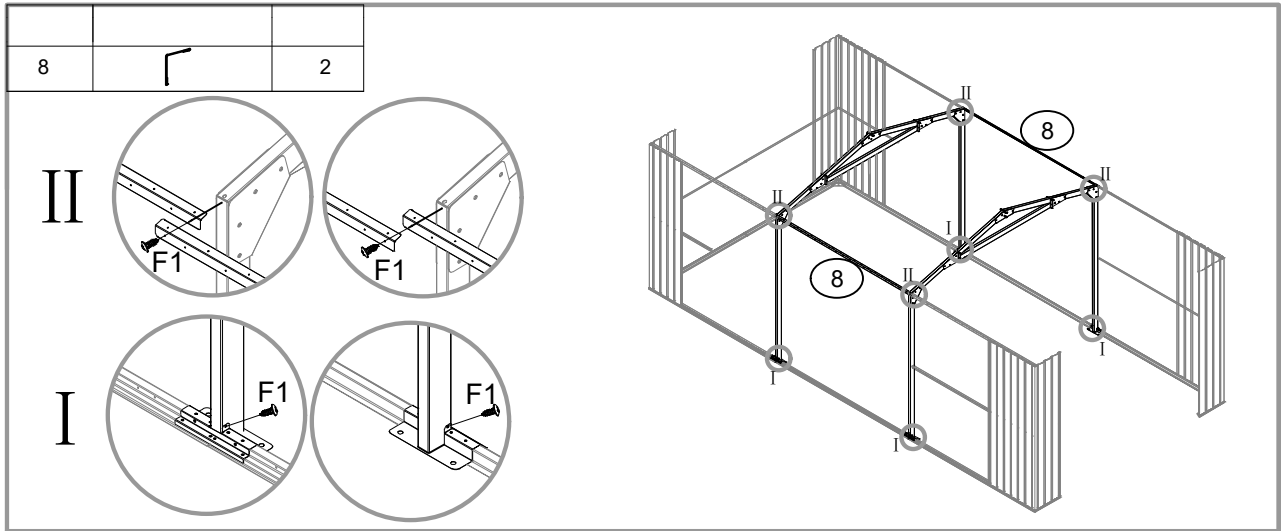



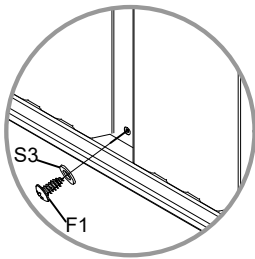
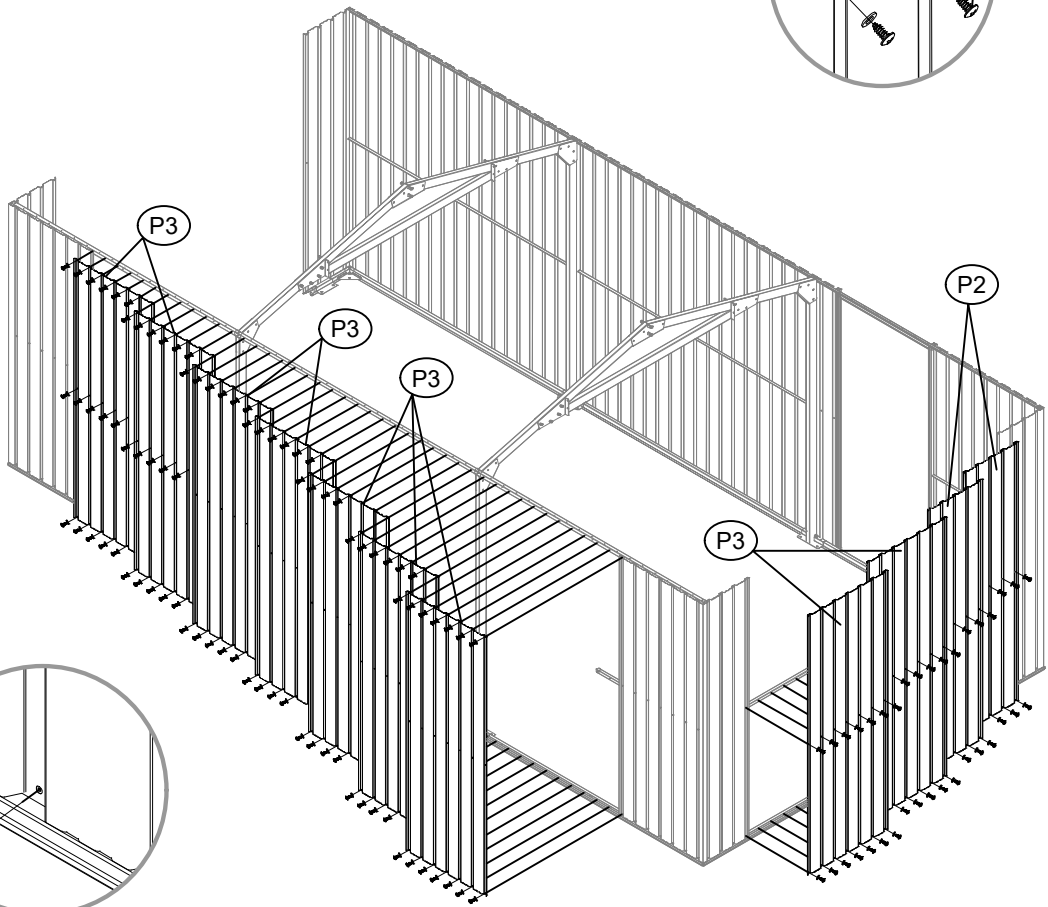
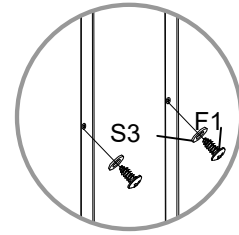

P3		9
P2		2



22		1
24		1
10L		1
10R		1

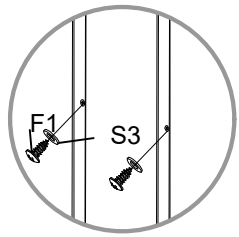
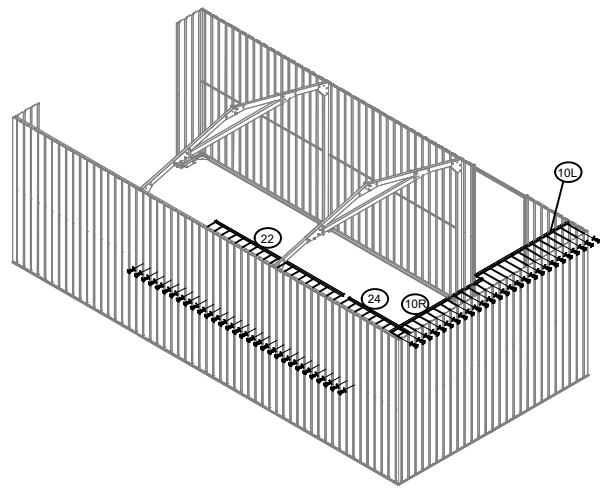

DE Die Tür wird auf der rechten Seite installiert.
CZ Dveře jsou instalovány vpravo.
SK Dvere sú nainštalované napravo.
PL Drzwi są montowane po prawej stronie.
HU Az ajtót a jobb oldalra kell felszerelni.
RO Ușa este instalată pe partea dreaptă.

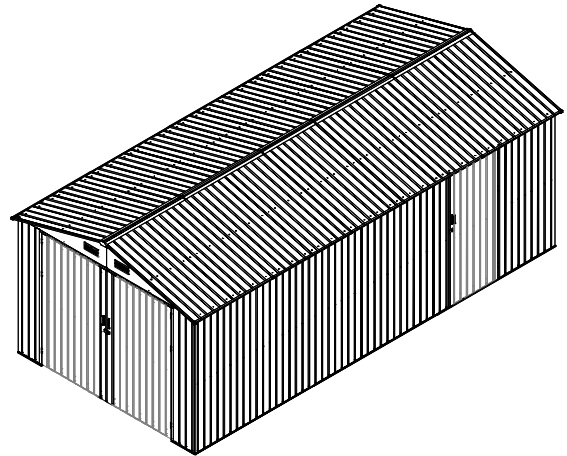

P2		1
P4		1
23L		1
6R		1

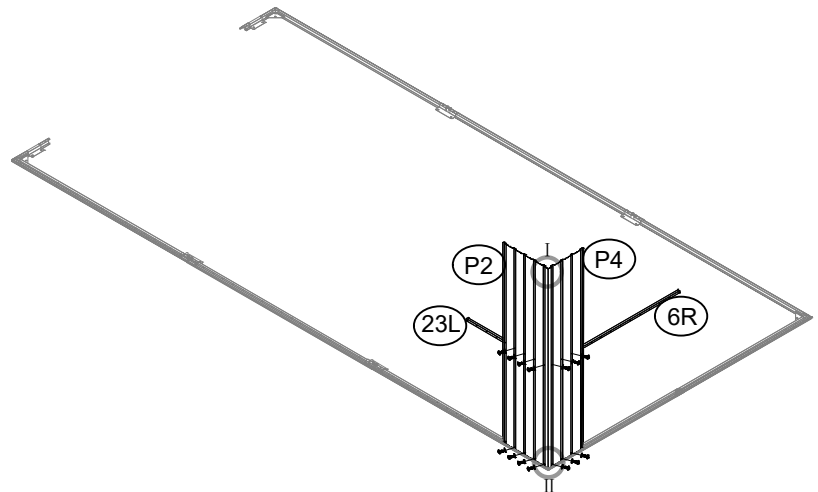
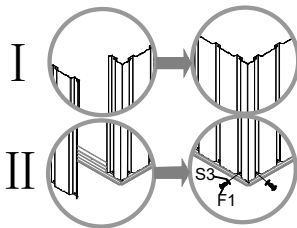

P3		1
P4		1
23R		1
6L		1

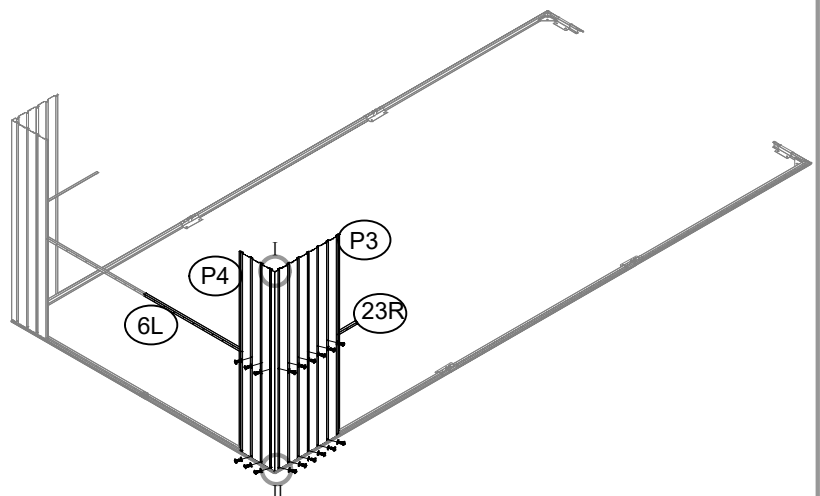
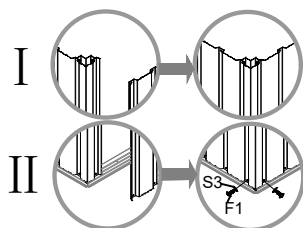

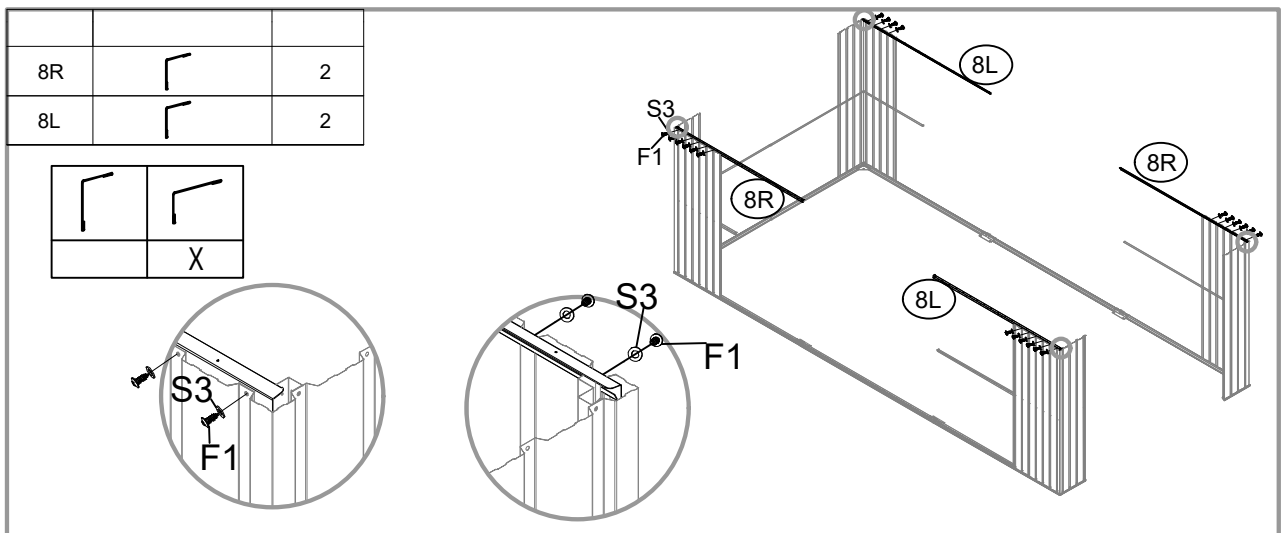
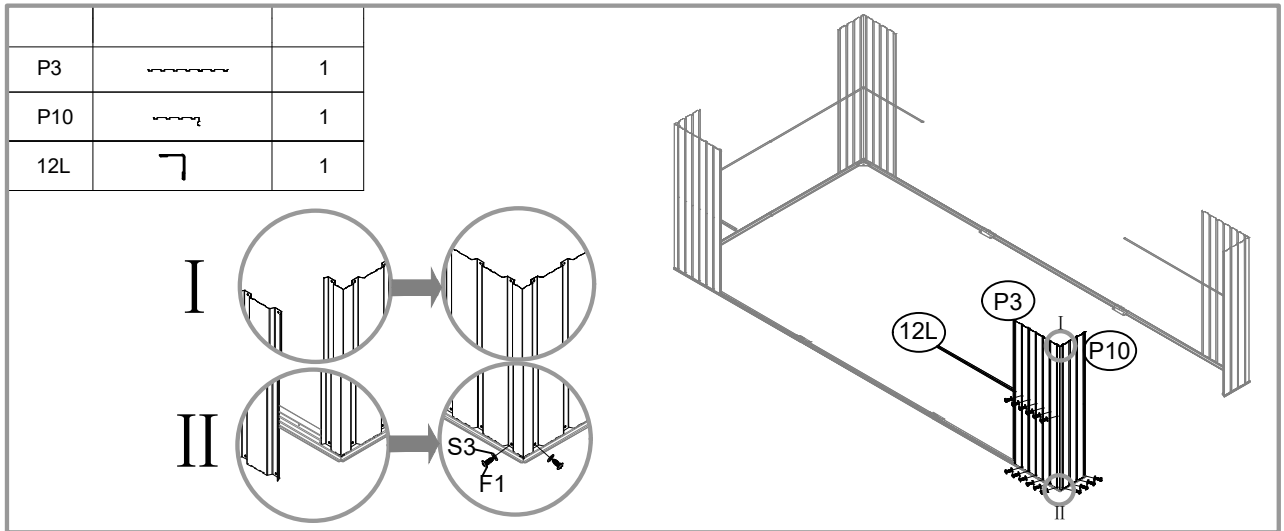
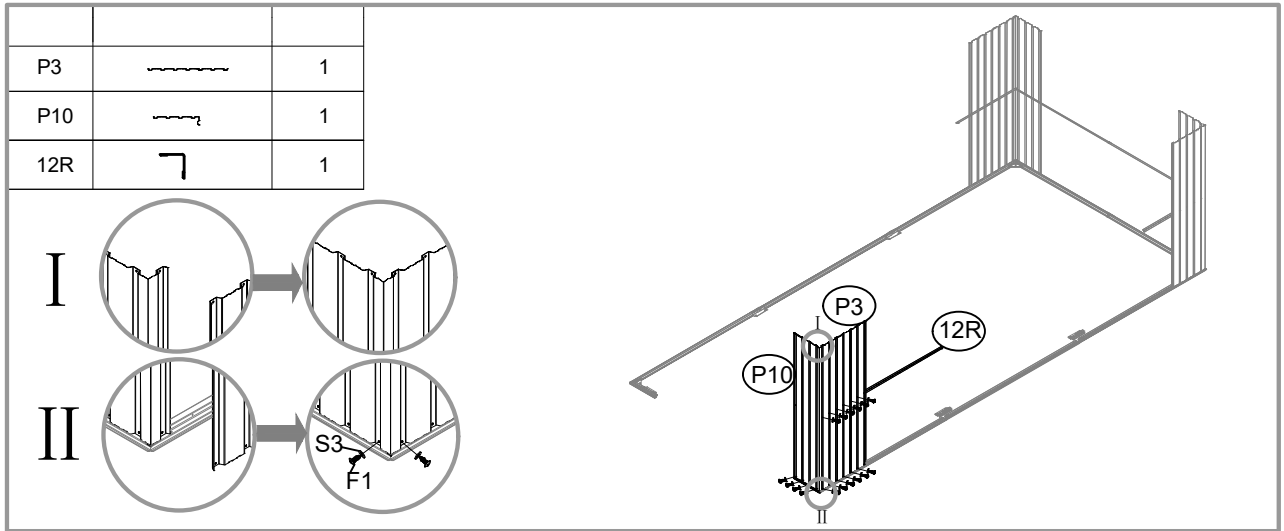

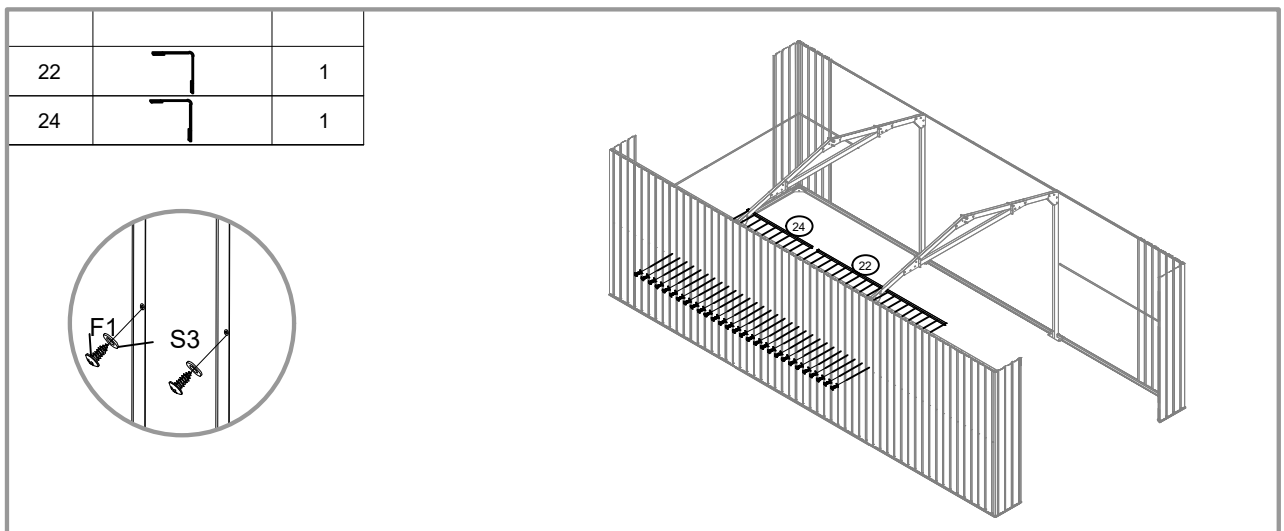
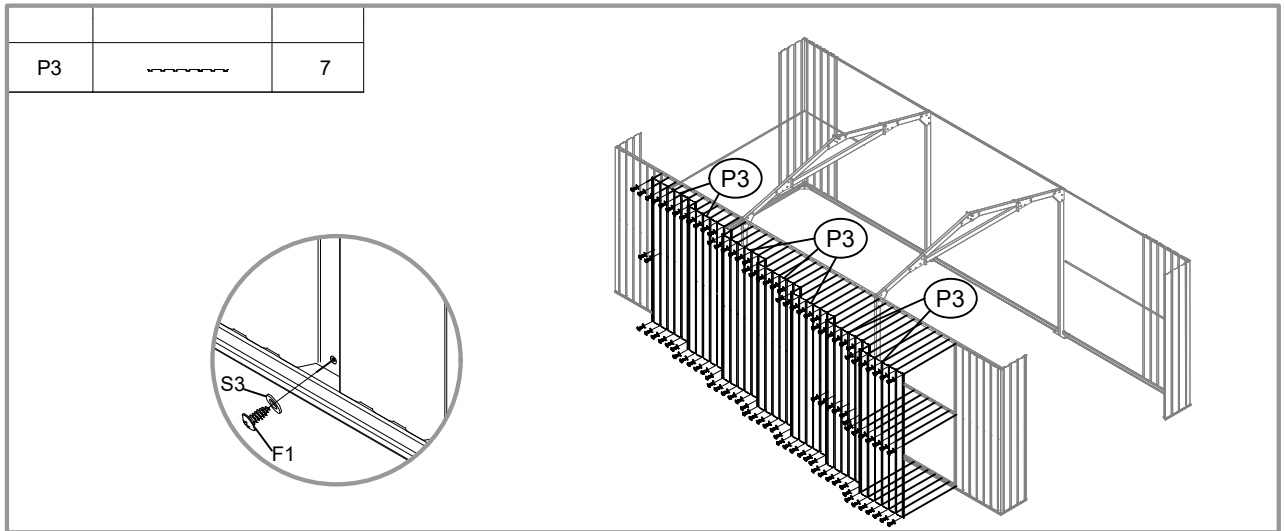
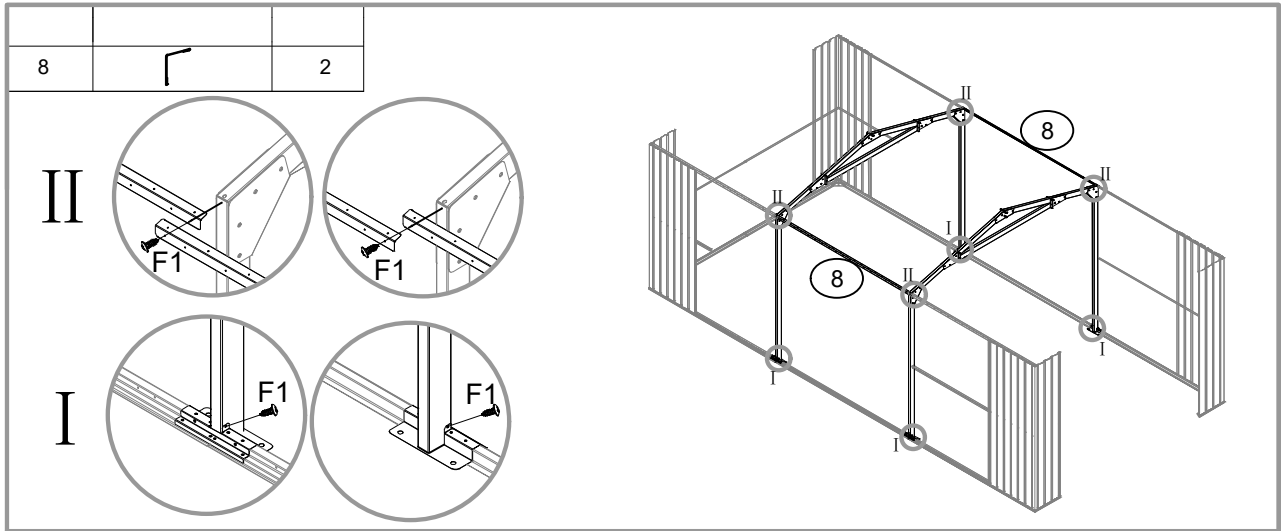

P3		6
P2		5

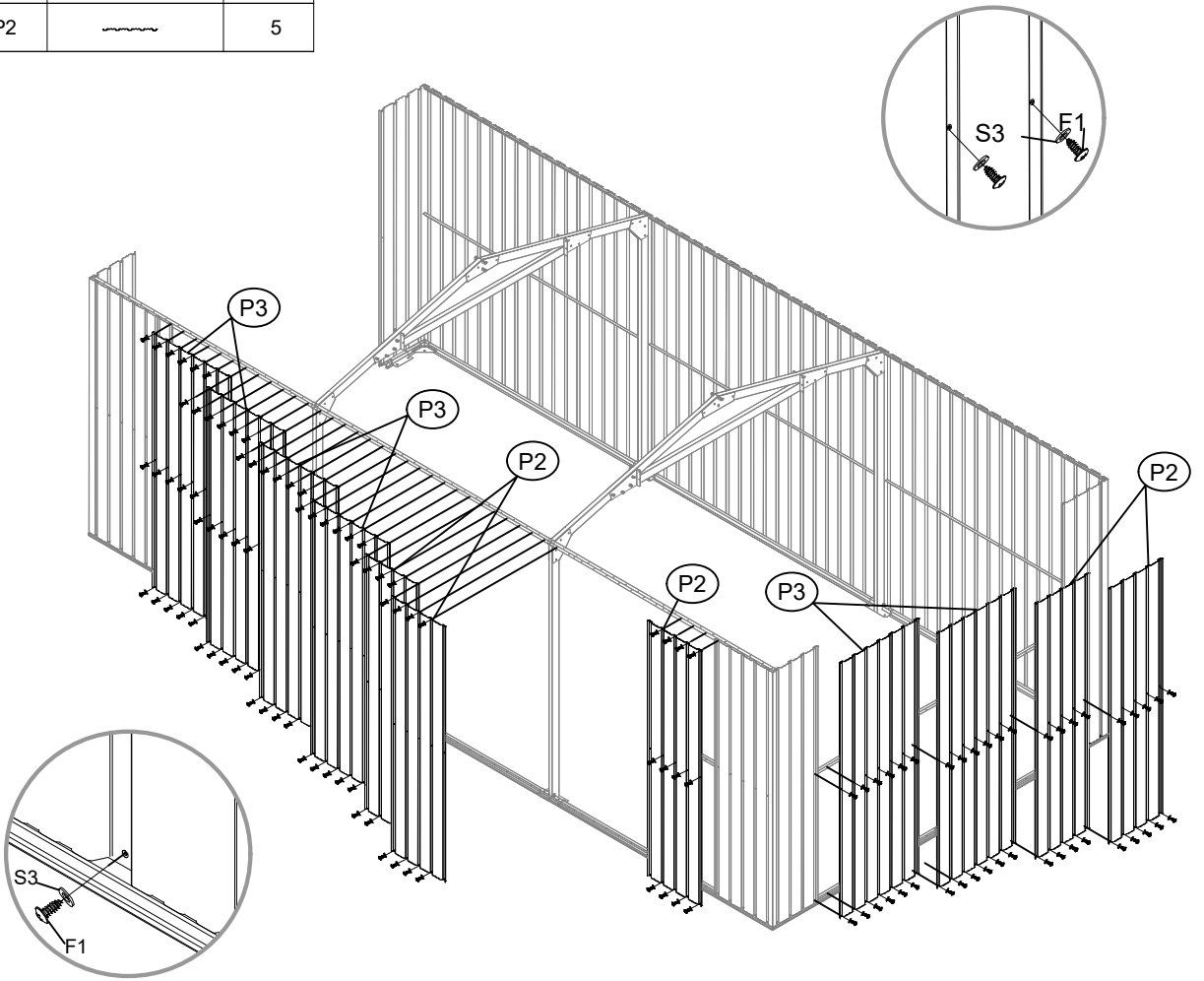

10L		1
10R		1
22		1
25L		1
25R		1
35		1

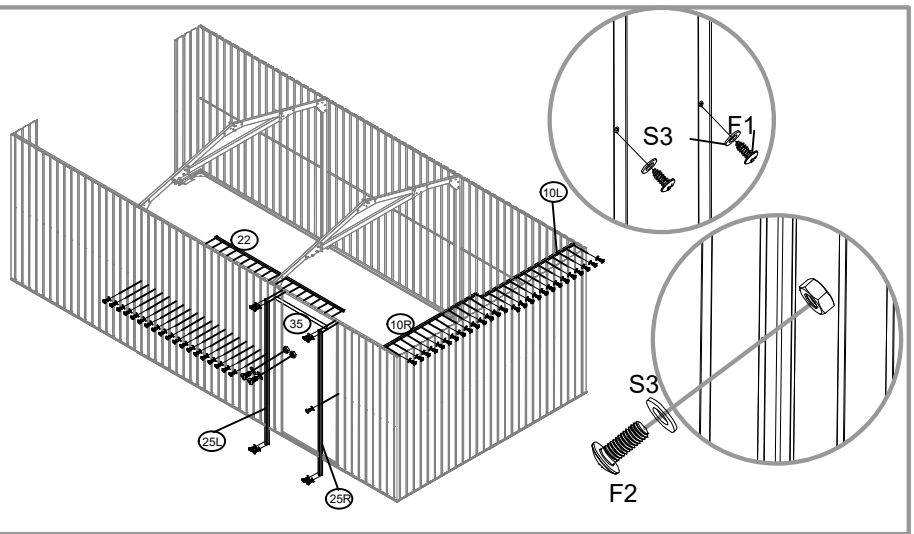

DE Die folgende Montage bezieht sich auf die Fronttür und das Dach; bitte ignorieren Sie die Darstellung der Seitentür in der Montageabbildung.

CZ Níže uvedená montáž se týká předních dveří a střechy. Prosím ignorujte směr bočních dveří v montážním obrázku.



SK Nasledujúca montáž sa týka predných dverí a strechy. Prosím, ignorujte smer bočných dverí na montážnom obrázku.

PL Poniższa instrukcja montażu dotyczy drzwi frontowych i dachu. Proszę zignorować kierunek drzwi bocznych na rysunku montażowym.



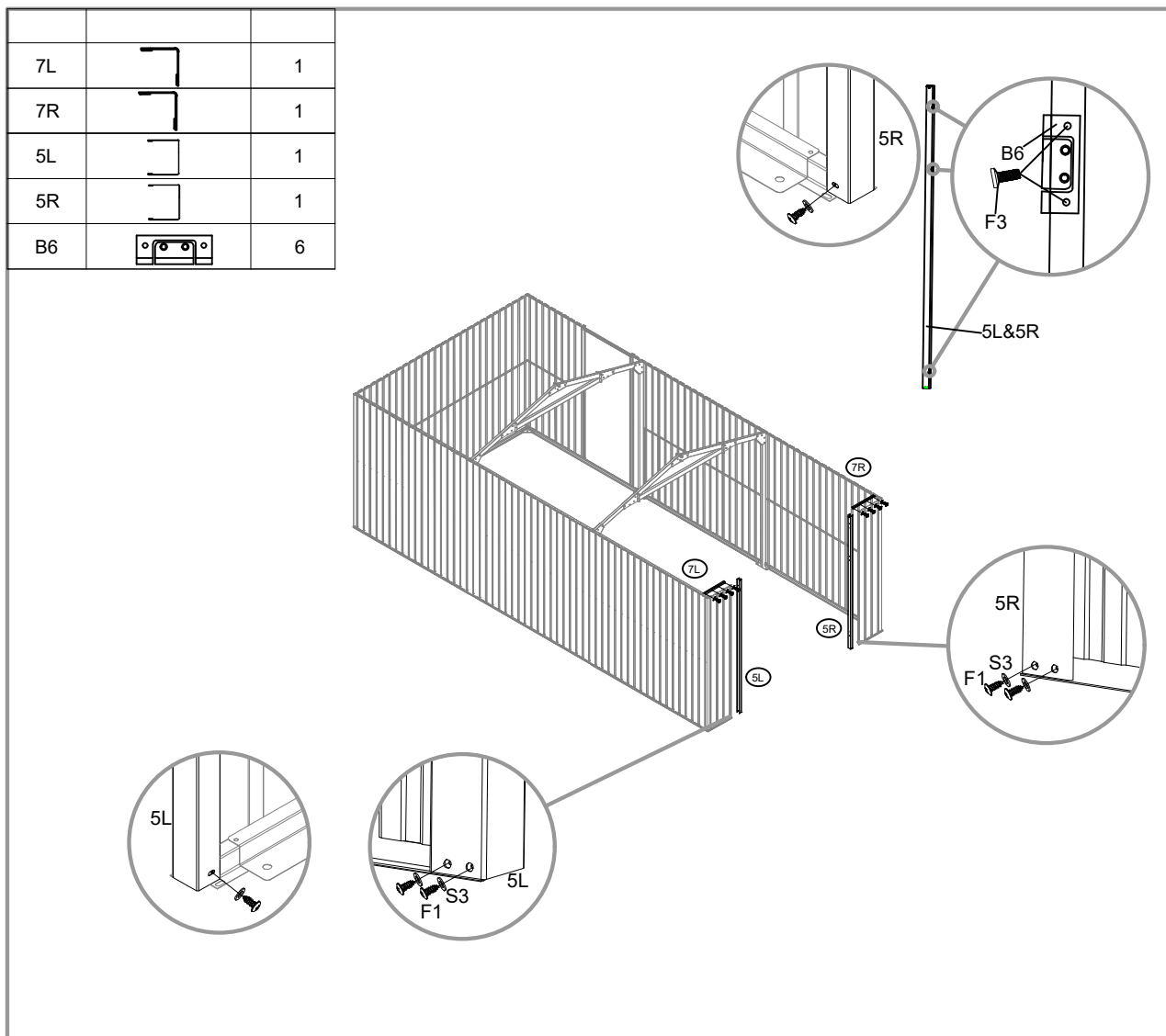

HU Az alábbi szerelési útmutató az elülső ajtóra és a tetőre vonatkozik. Kérjük, hagyja figyelmen kívül a mellékelt ábrán a mellékajtó irányát.

RO Instrucțiunile de mai jos se referă la montarea ușii frontale și a acoperișului. Vă rugăm să ignorați orientarea ușii laterale din imaginea de asamblare.

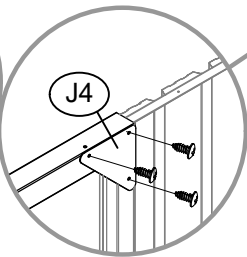
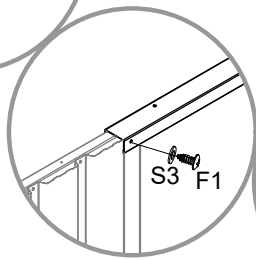
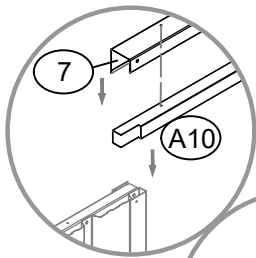
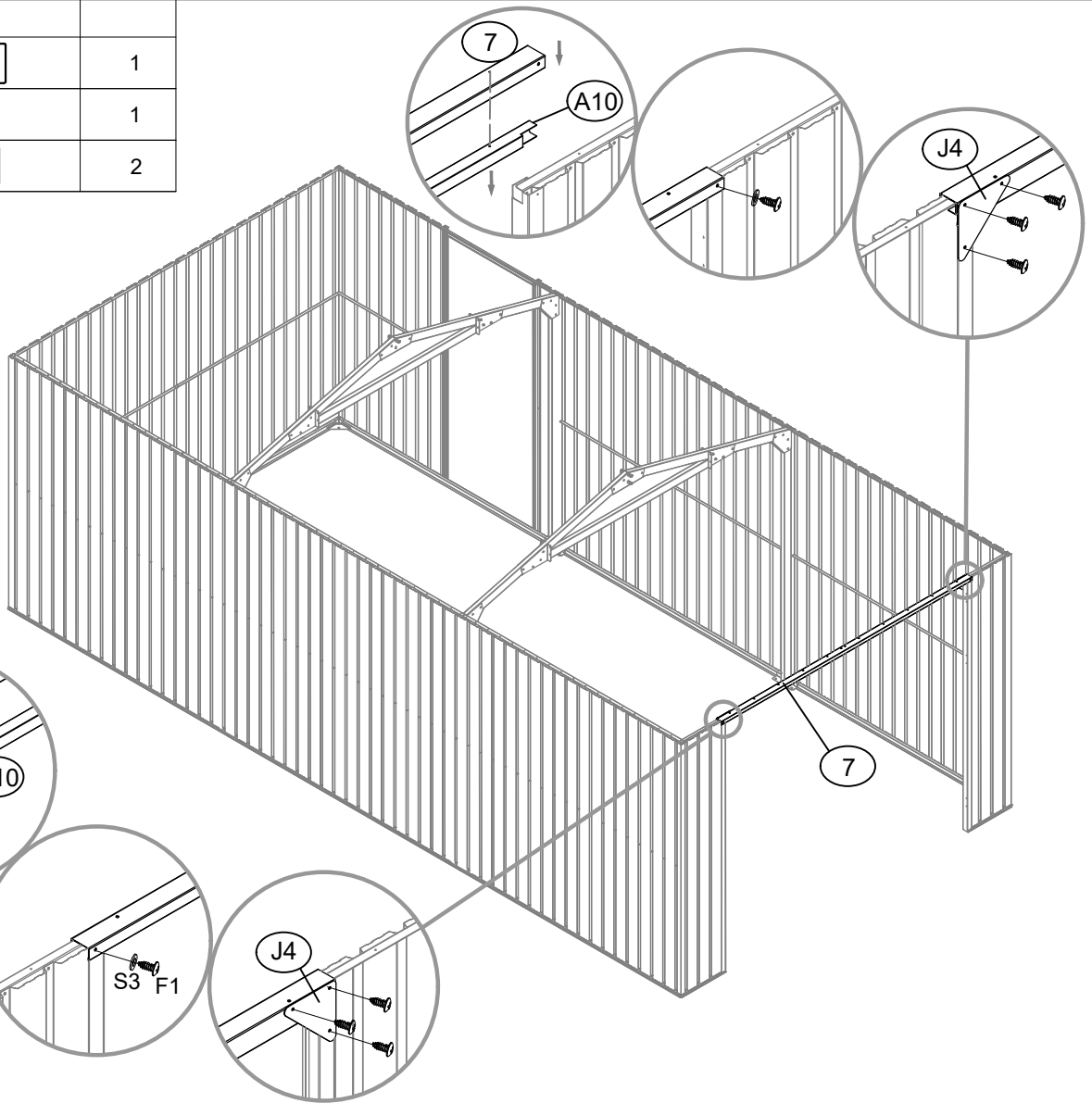

7		1
A10		1
J4		2



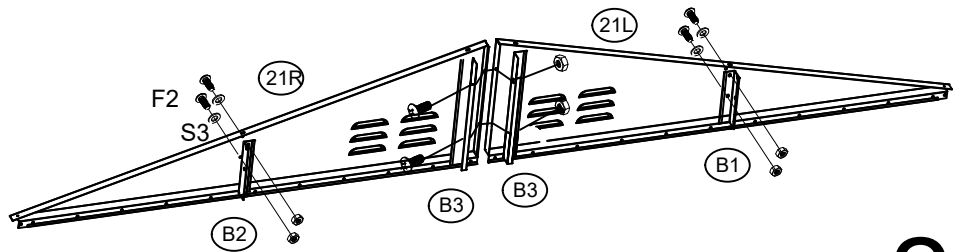

21L		2
21R		2
B3		4
B1		2
B2		2



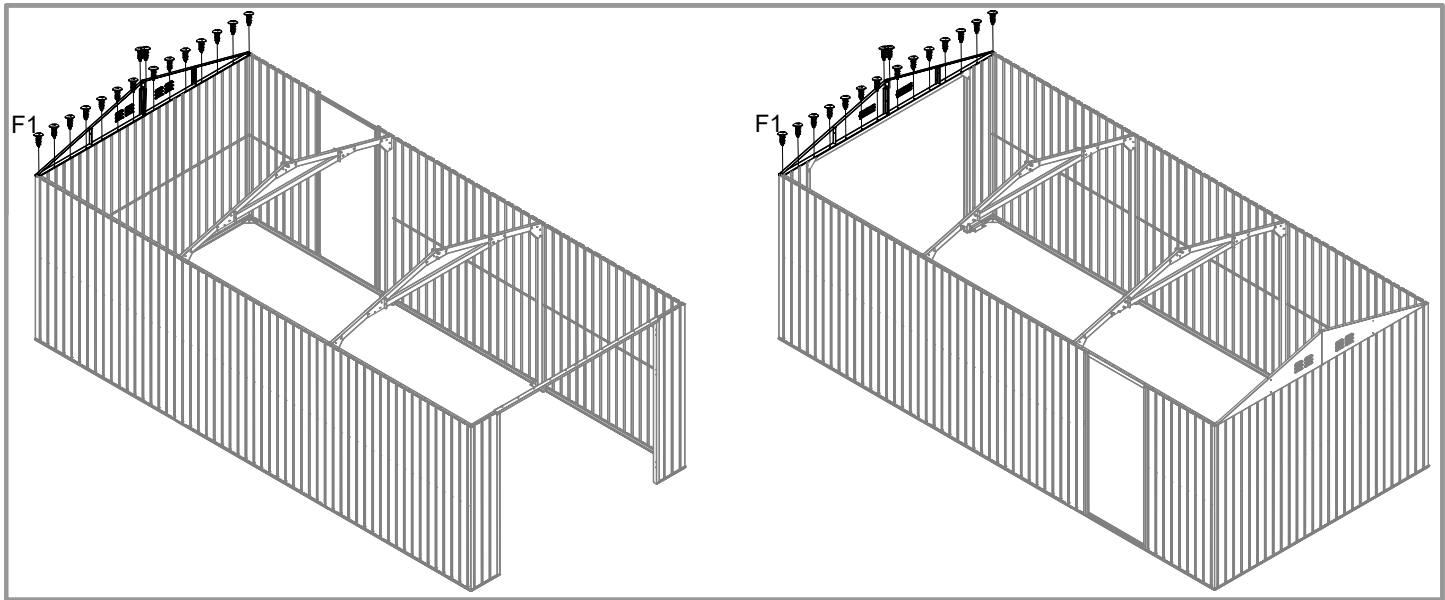

x2



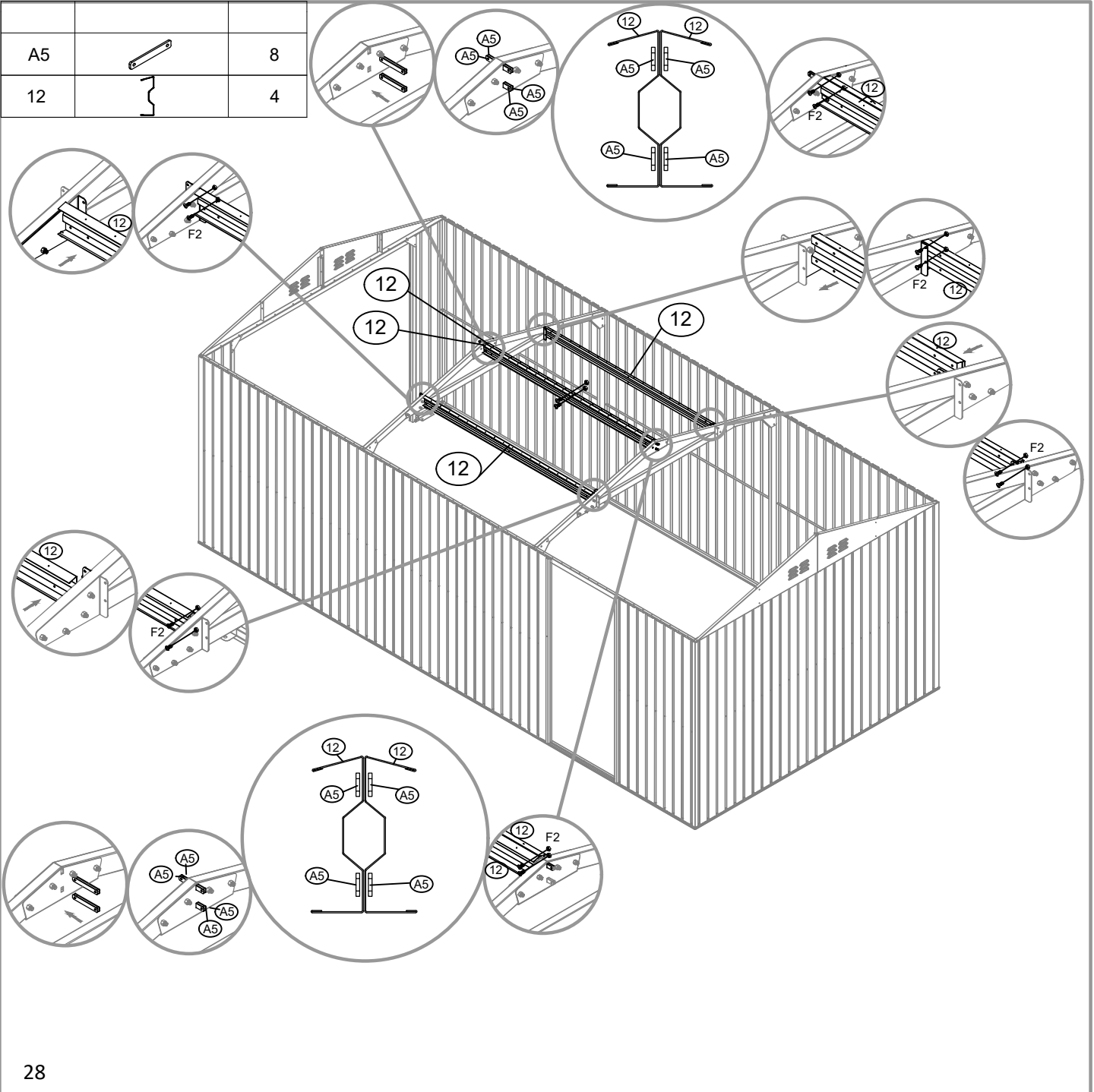



A5		8
12		4

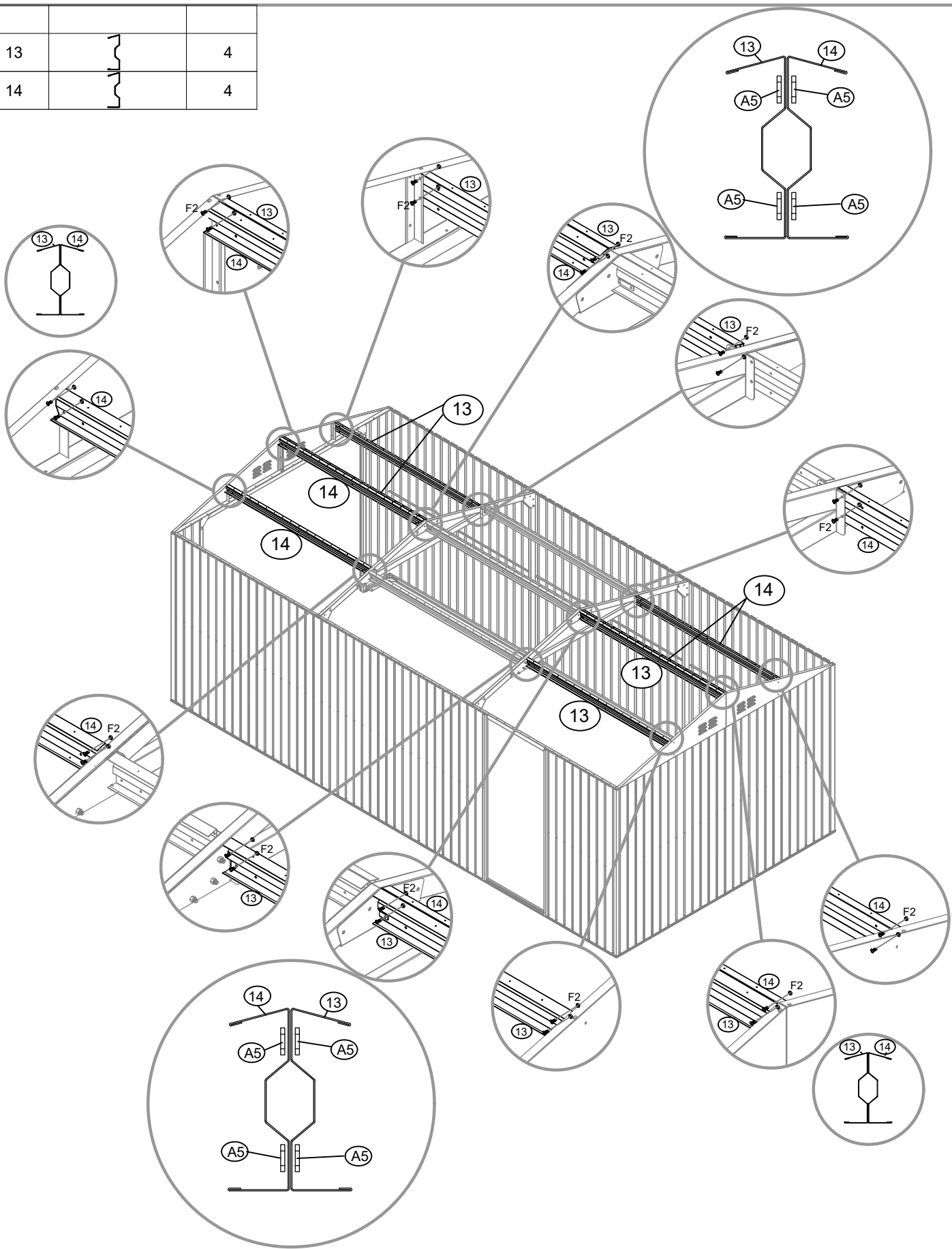

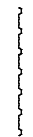
13		4
14		4

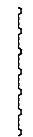

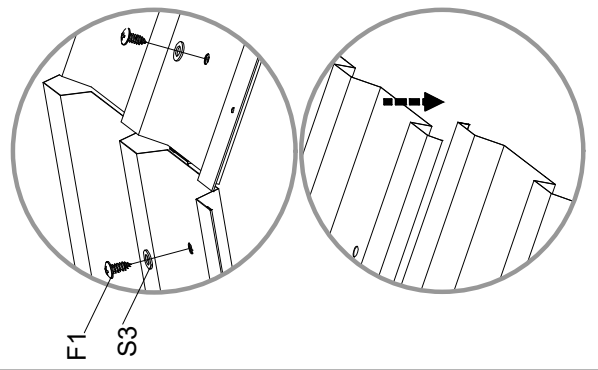
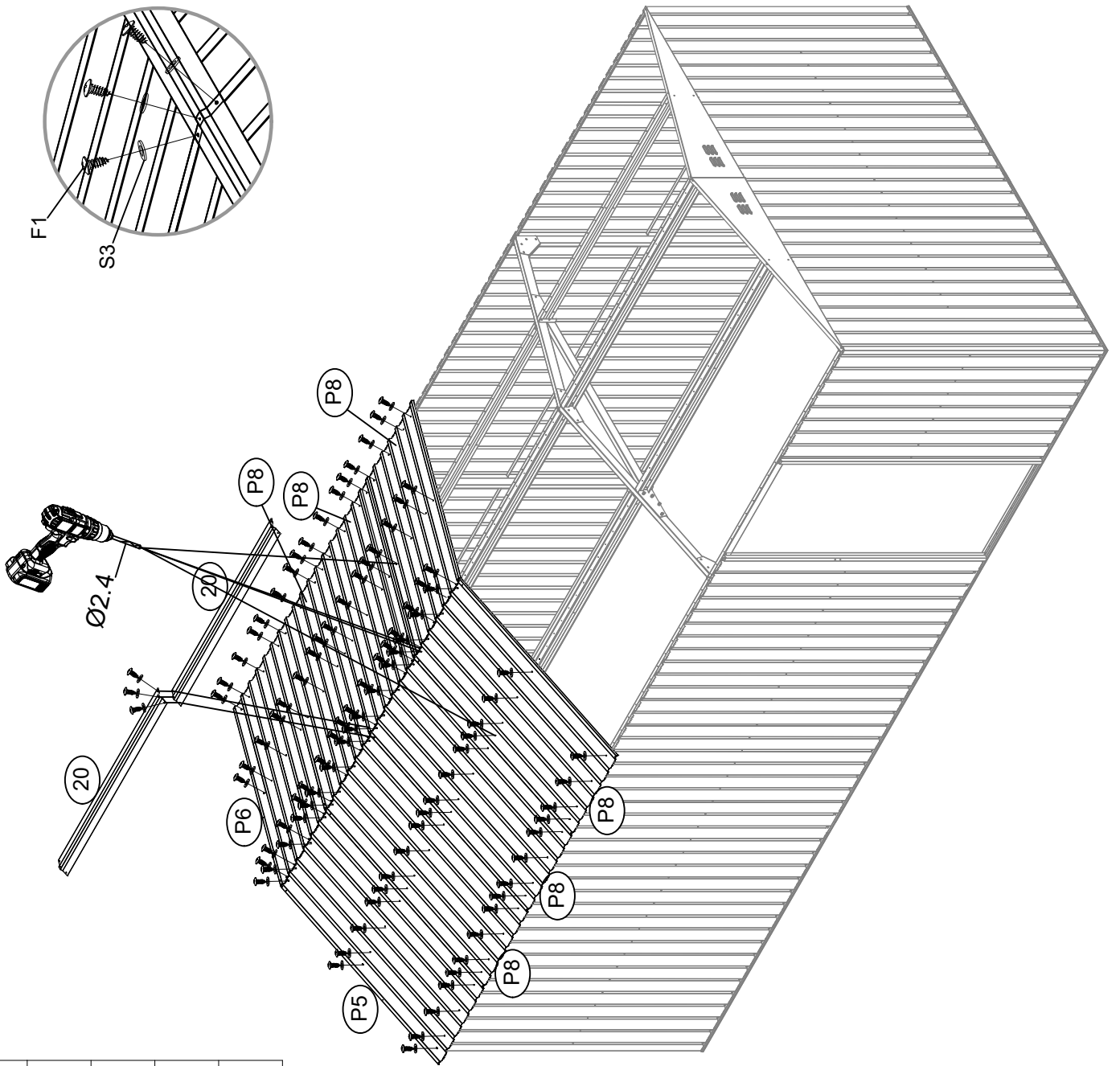

P5		1
P6		1
P8		6
20		2

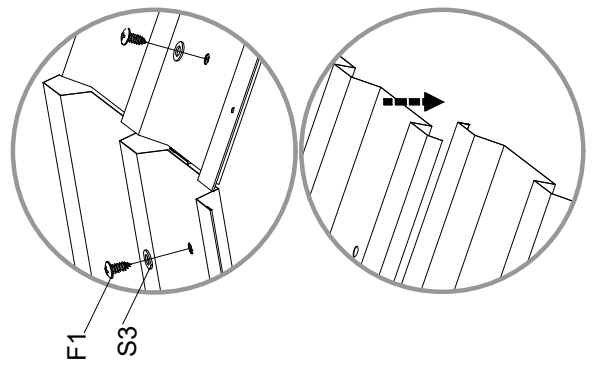
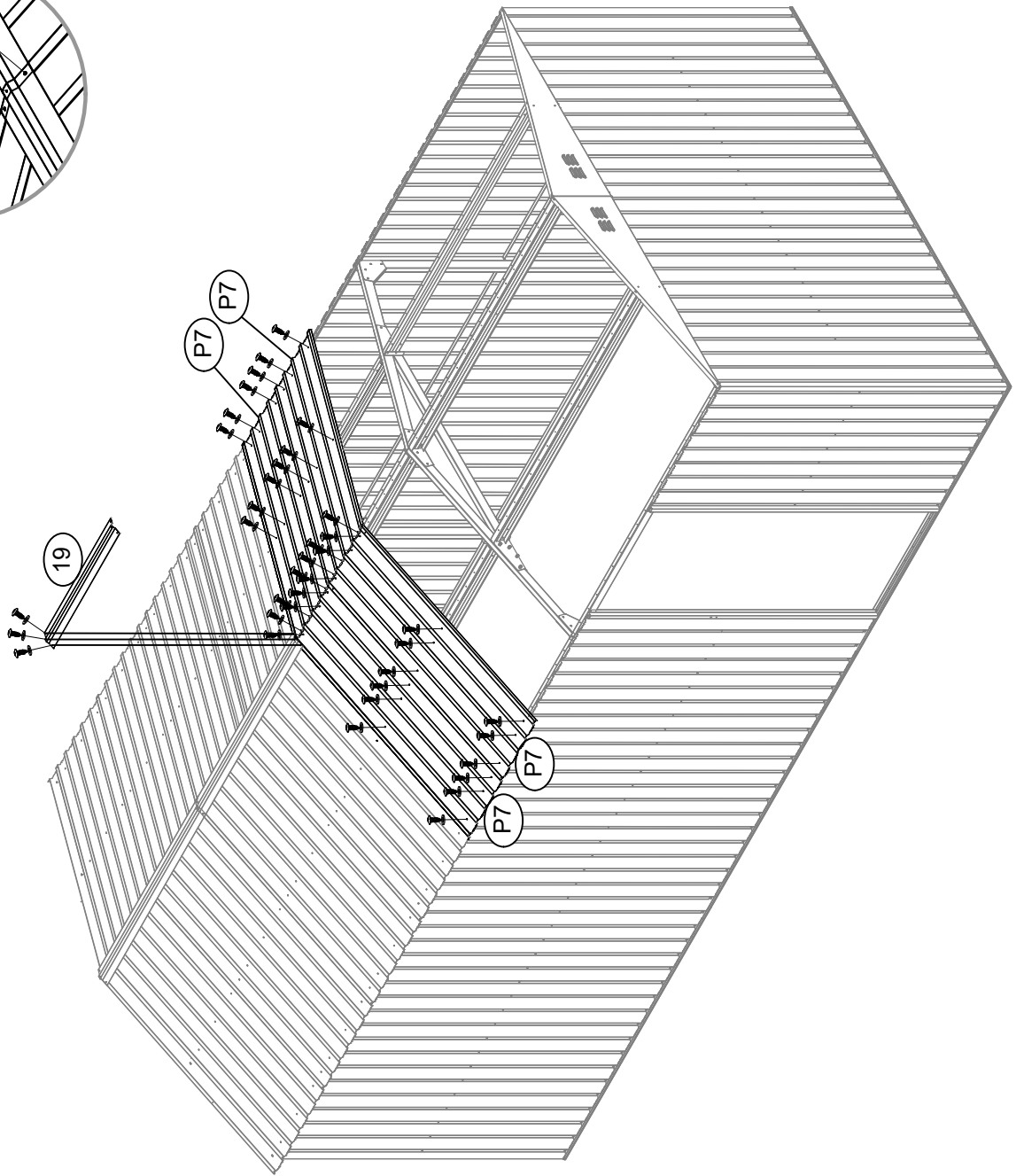
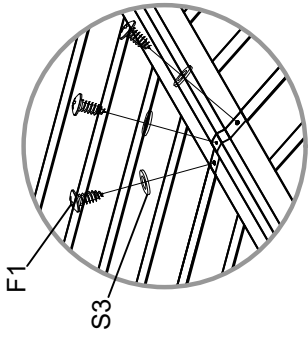

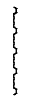
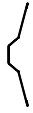

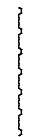
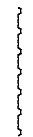
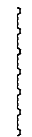



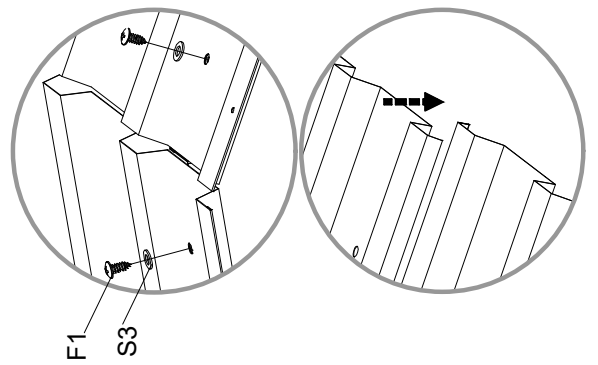
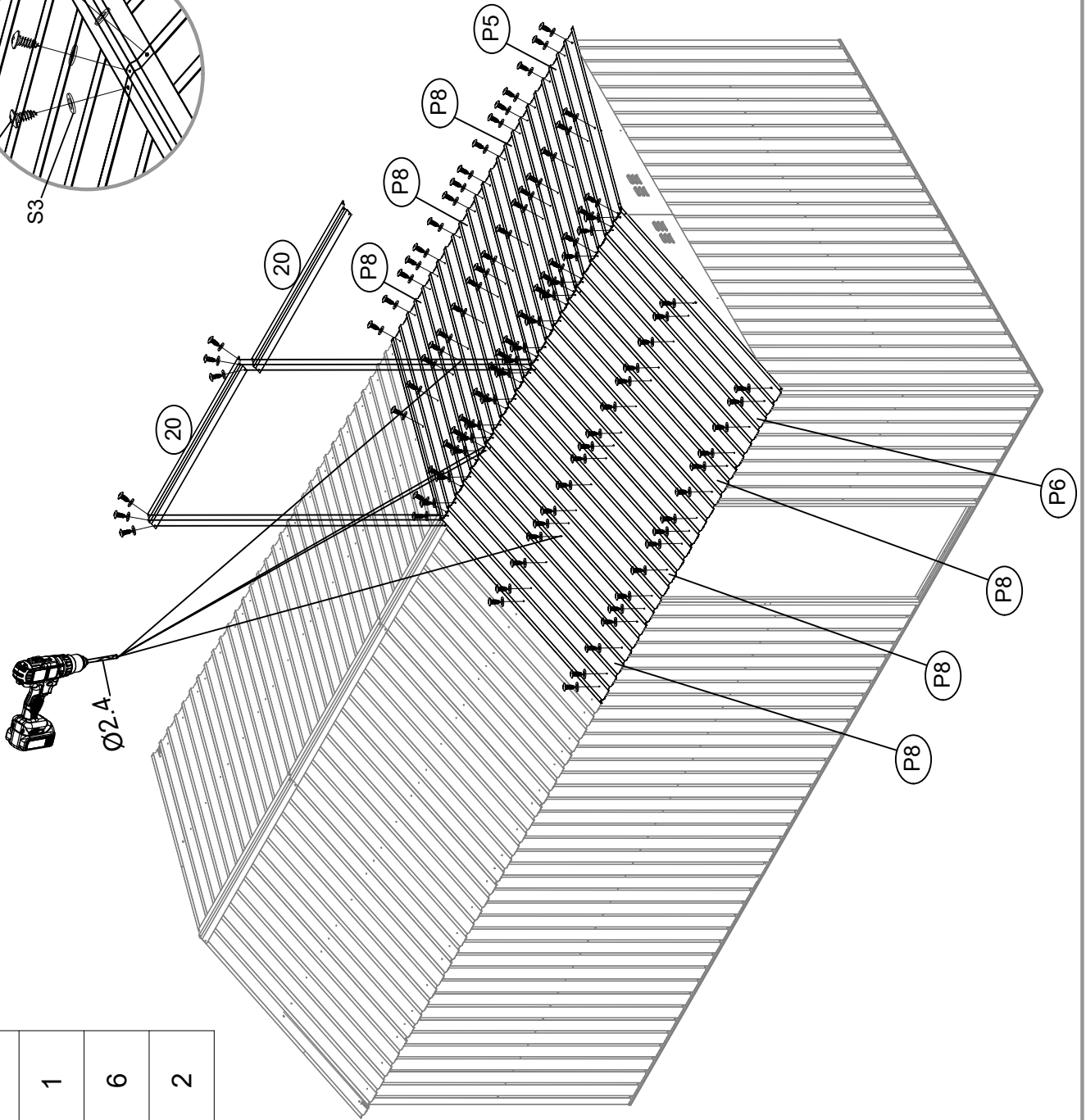
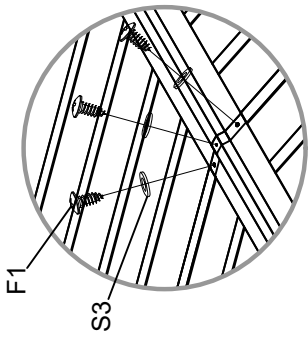







		4	
P7			
19		1	

P5		1
P6		1
P8		6
20		2

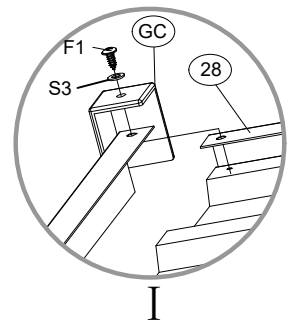
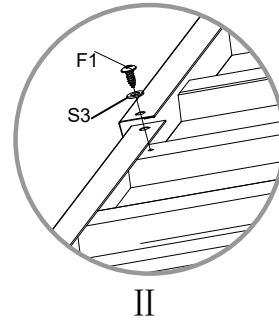
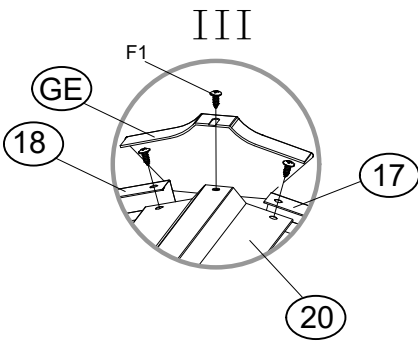
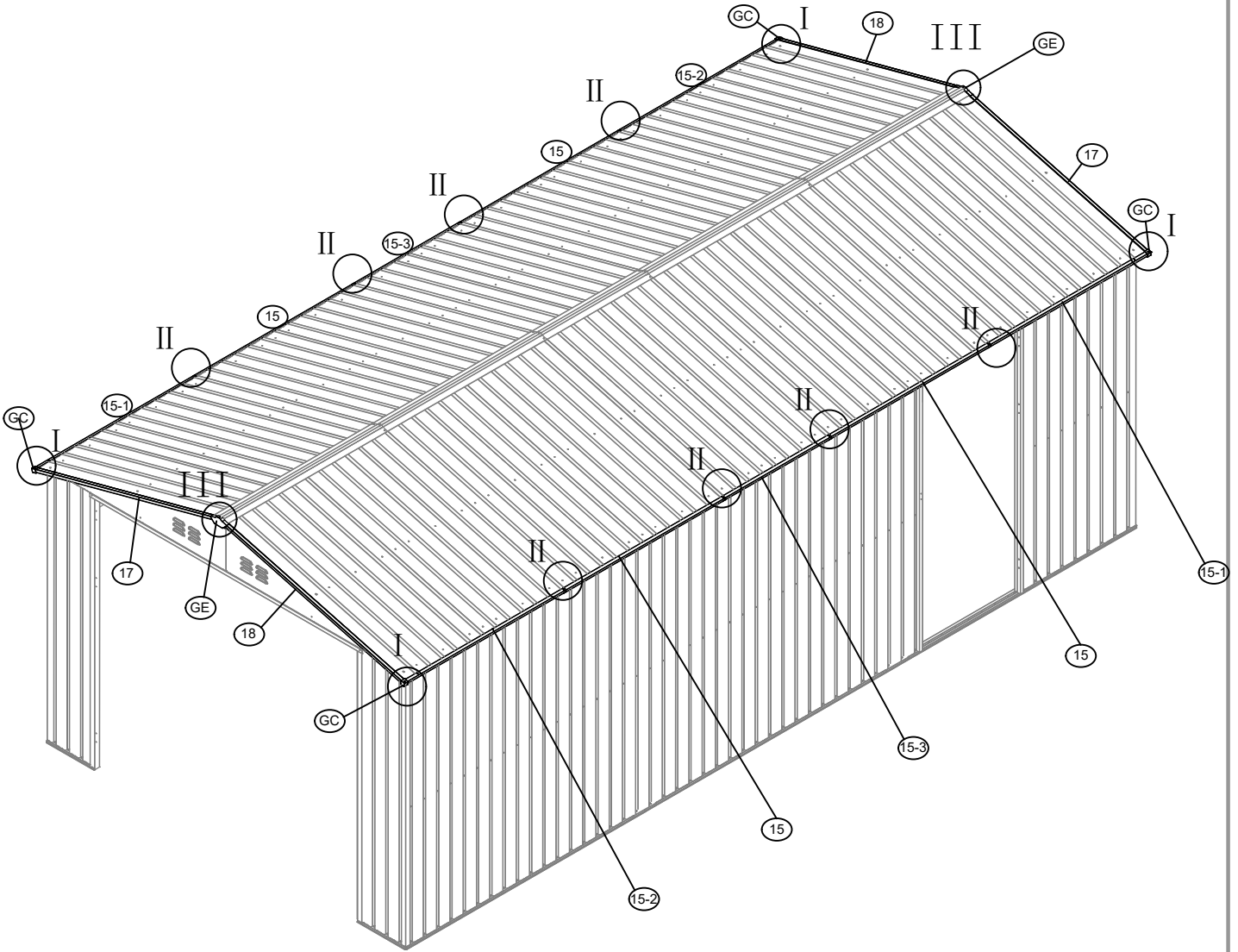





15-1		2	15-3		2
15-2		2	17		2
15		4	18		2
GC		4	GE		2

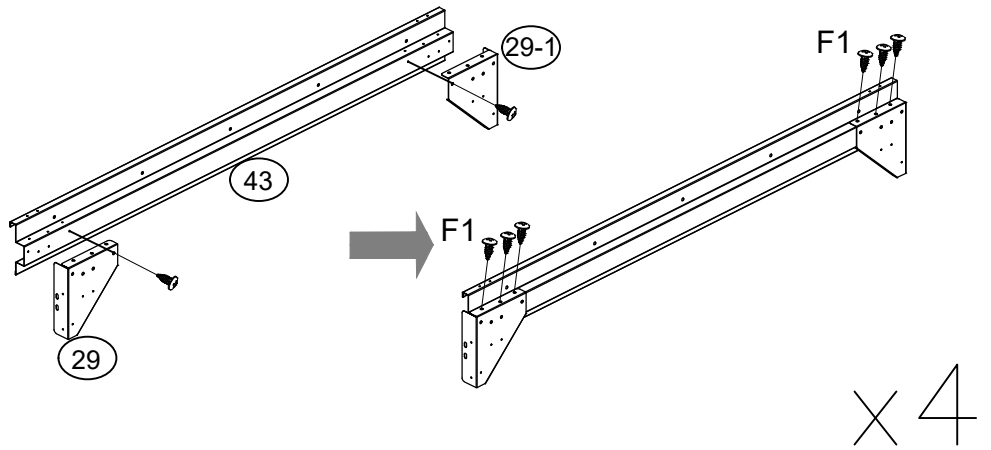



29		4
29-1		4
43		4

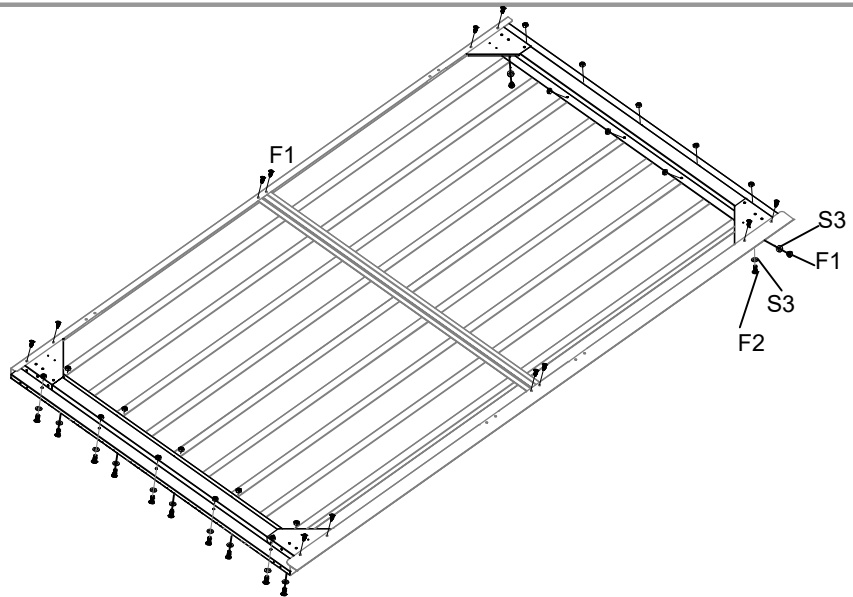
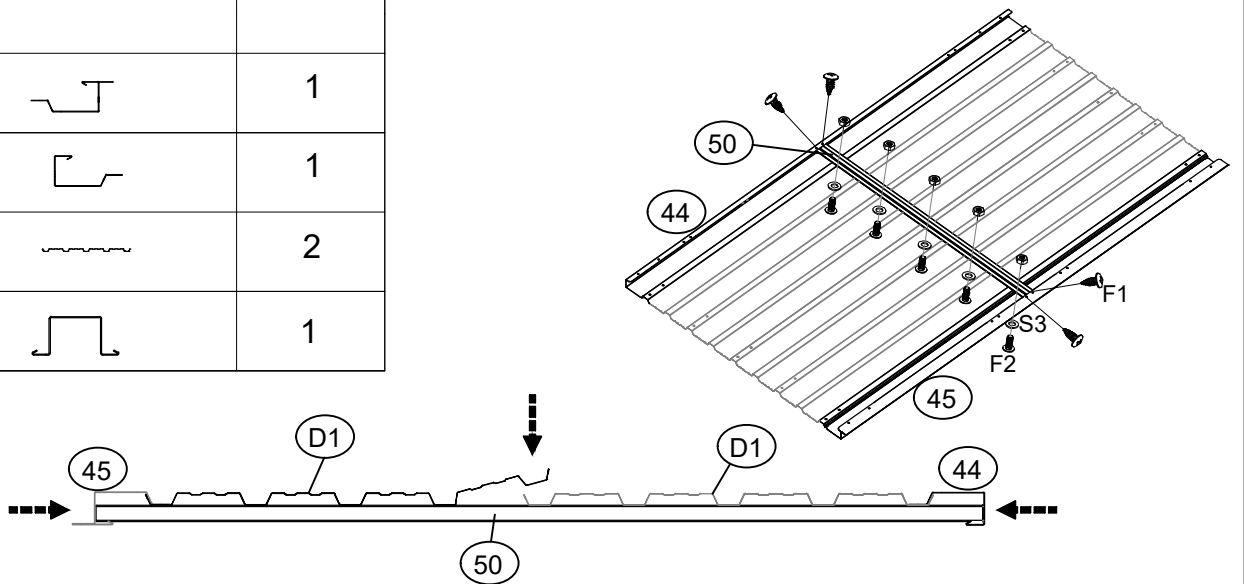

45		1
44		1
D1		2
50		1



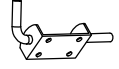

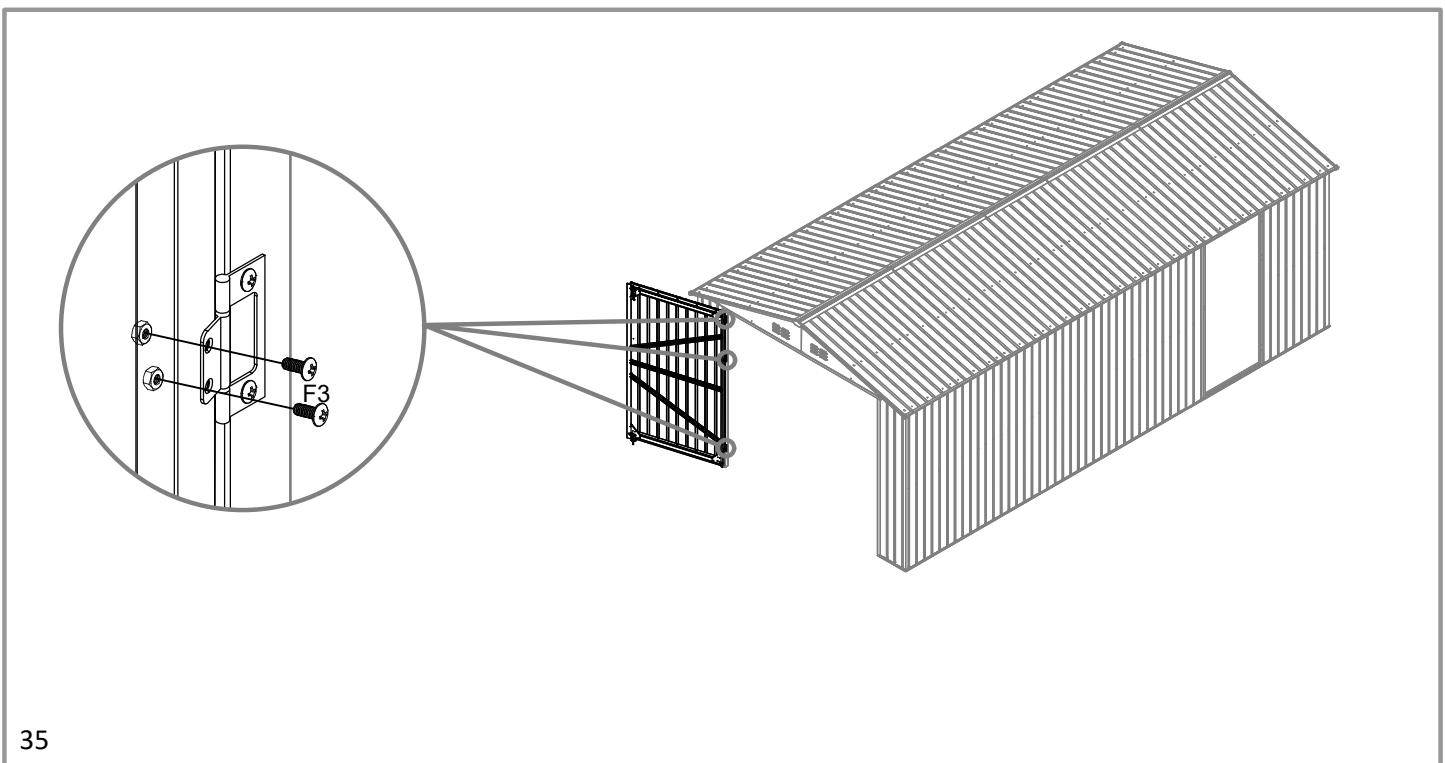
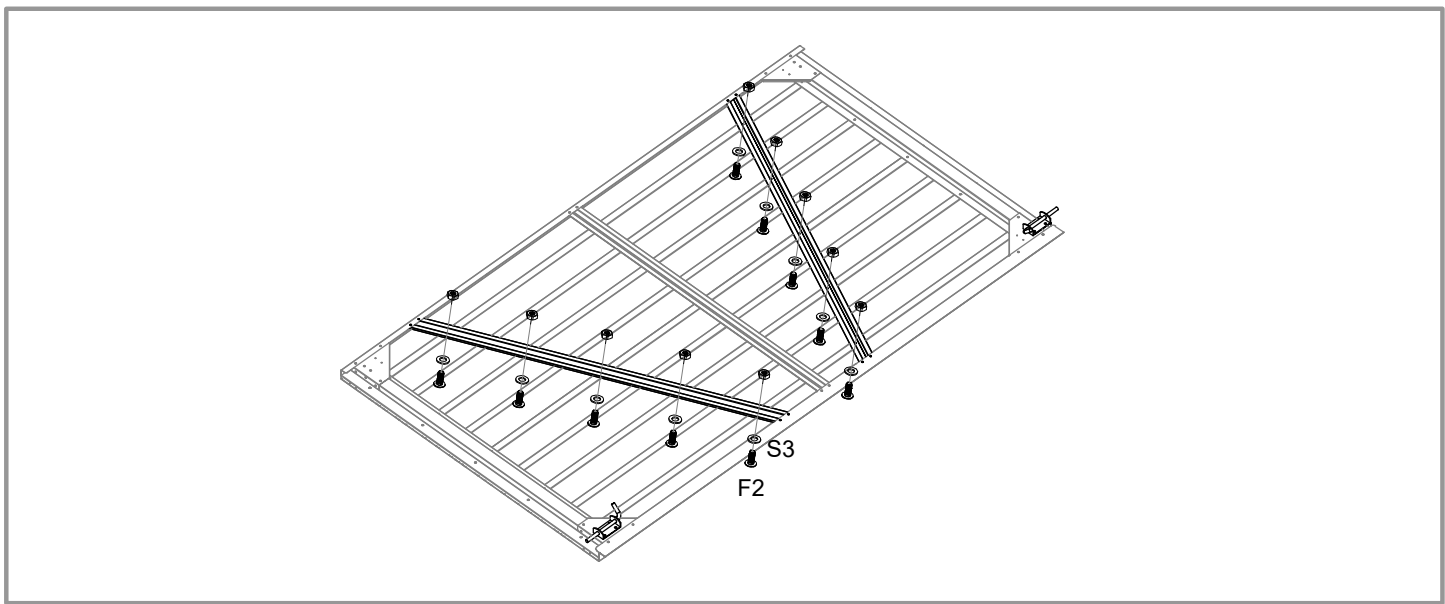
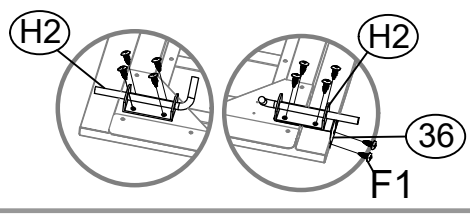
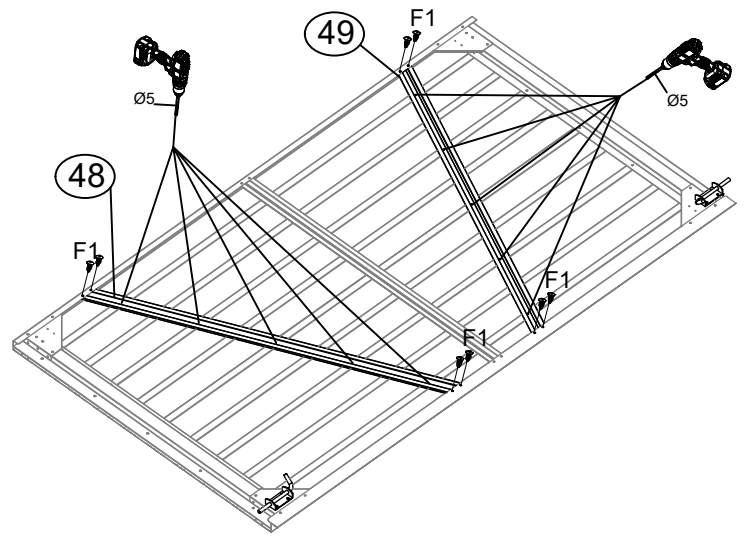
48		1
49		1
36		1
H2		2

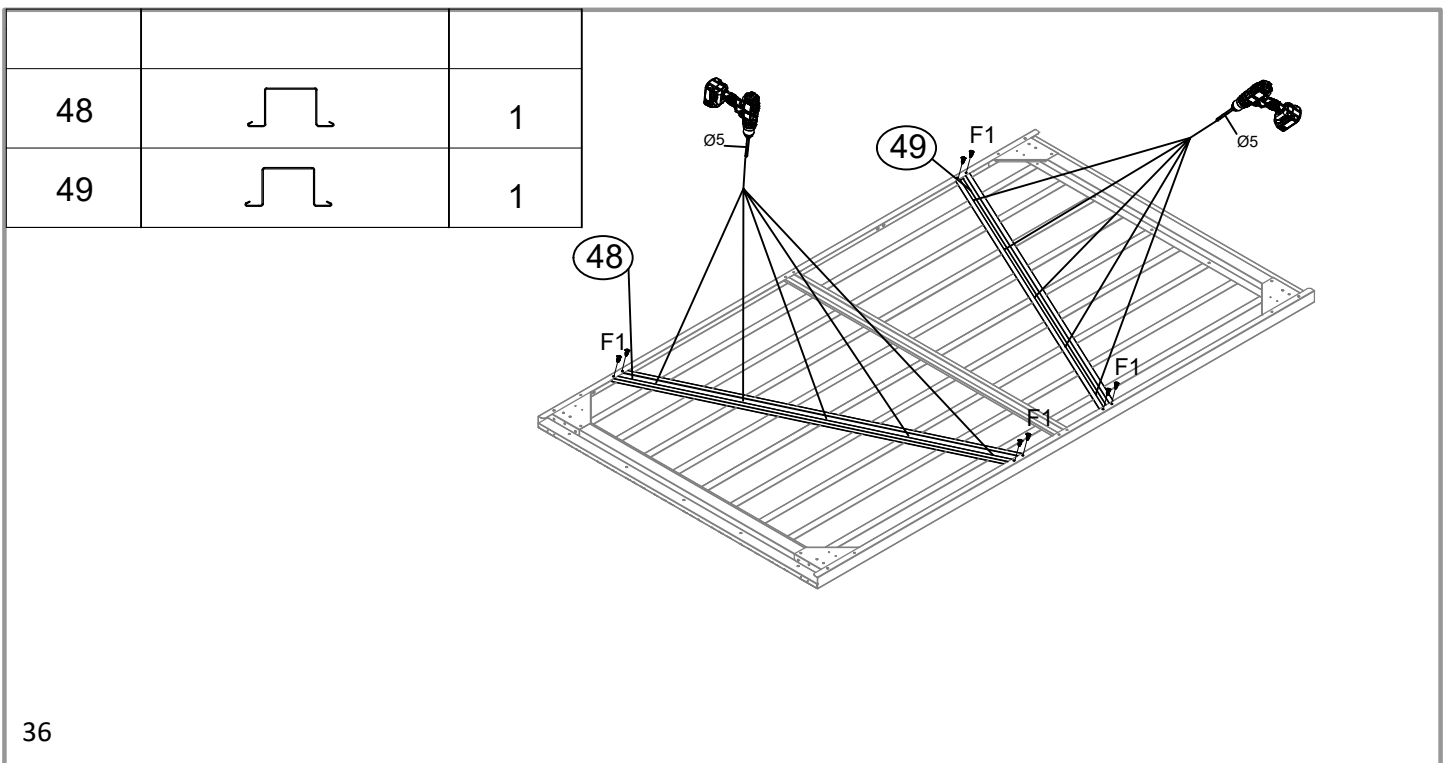
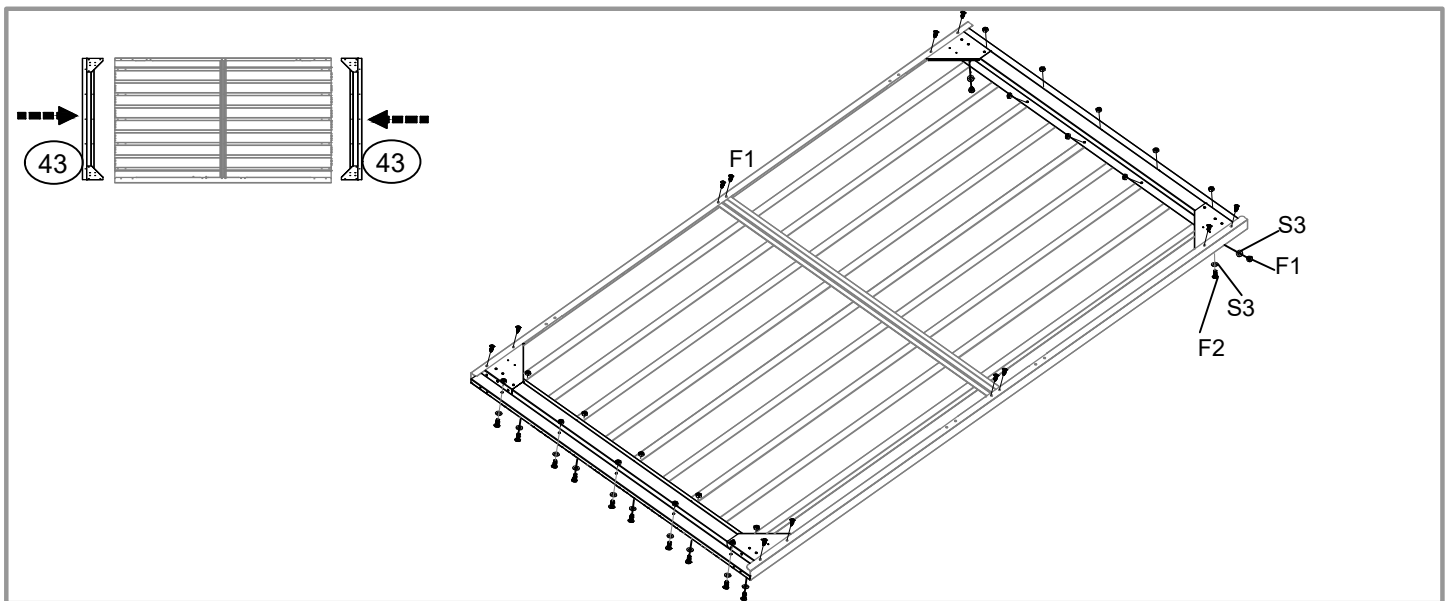
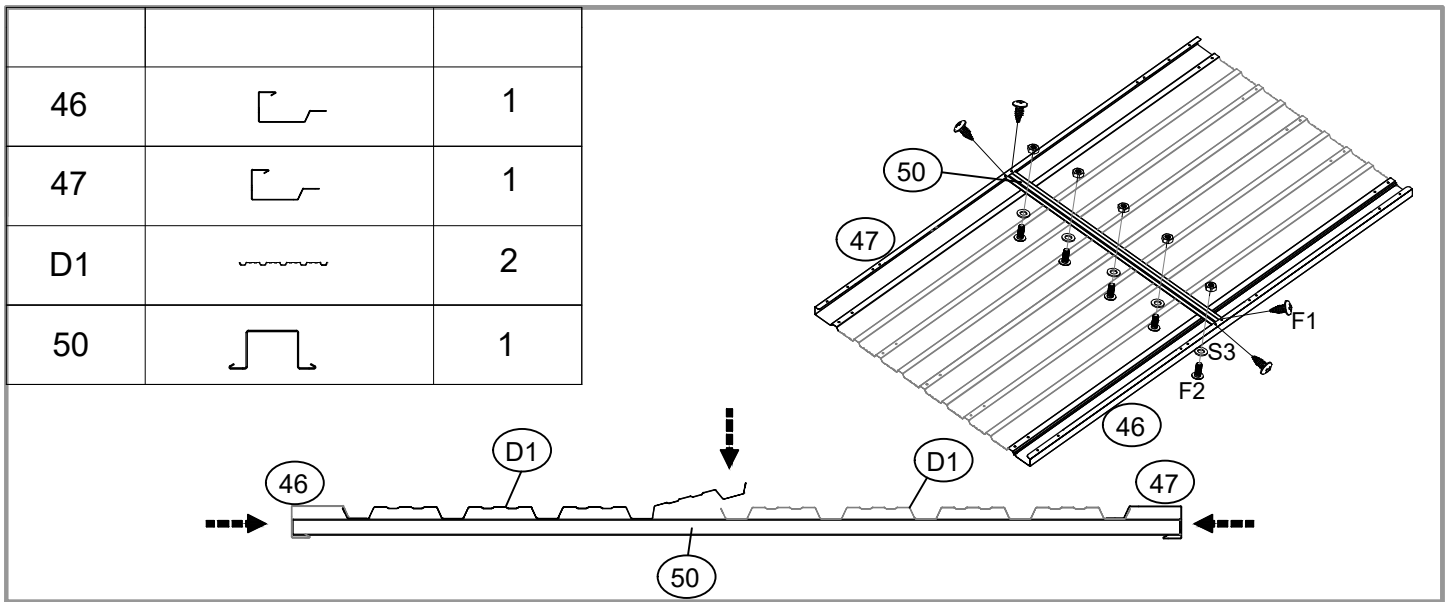

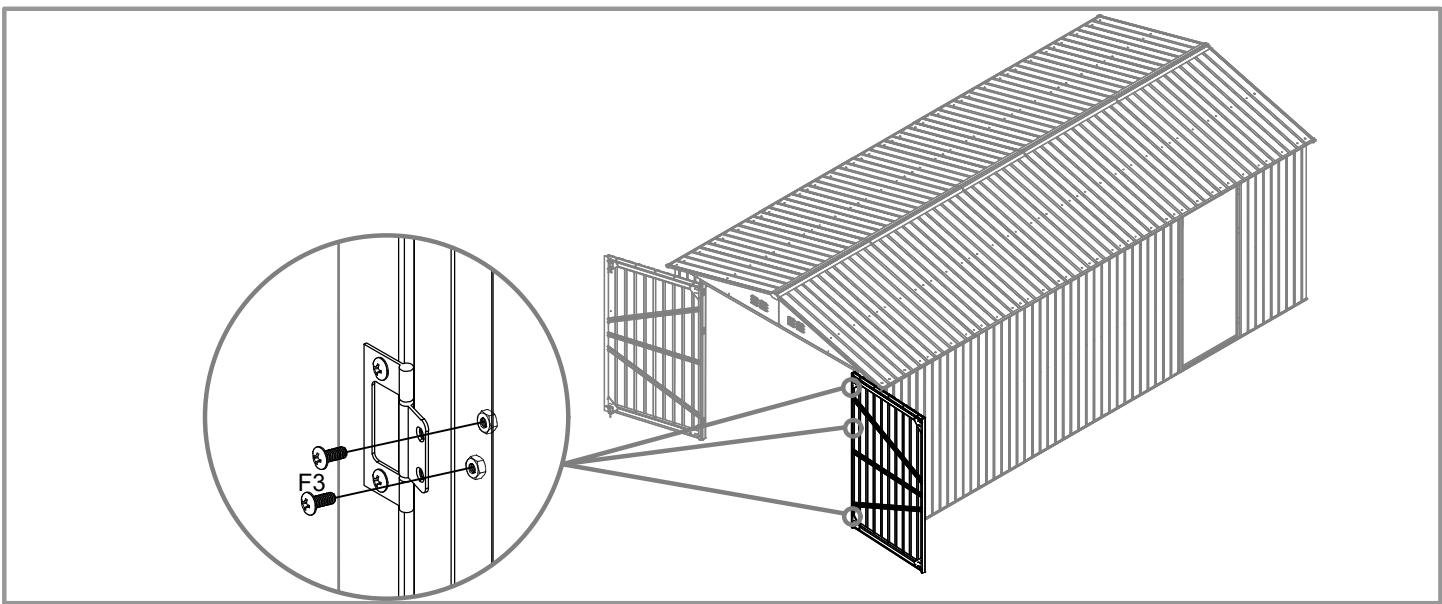
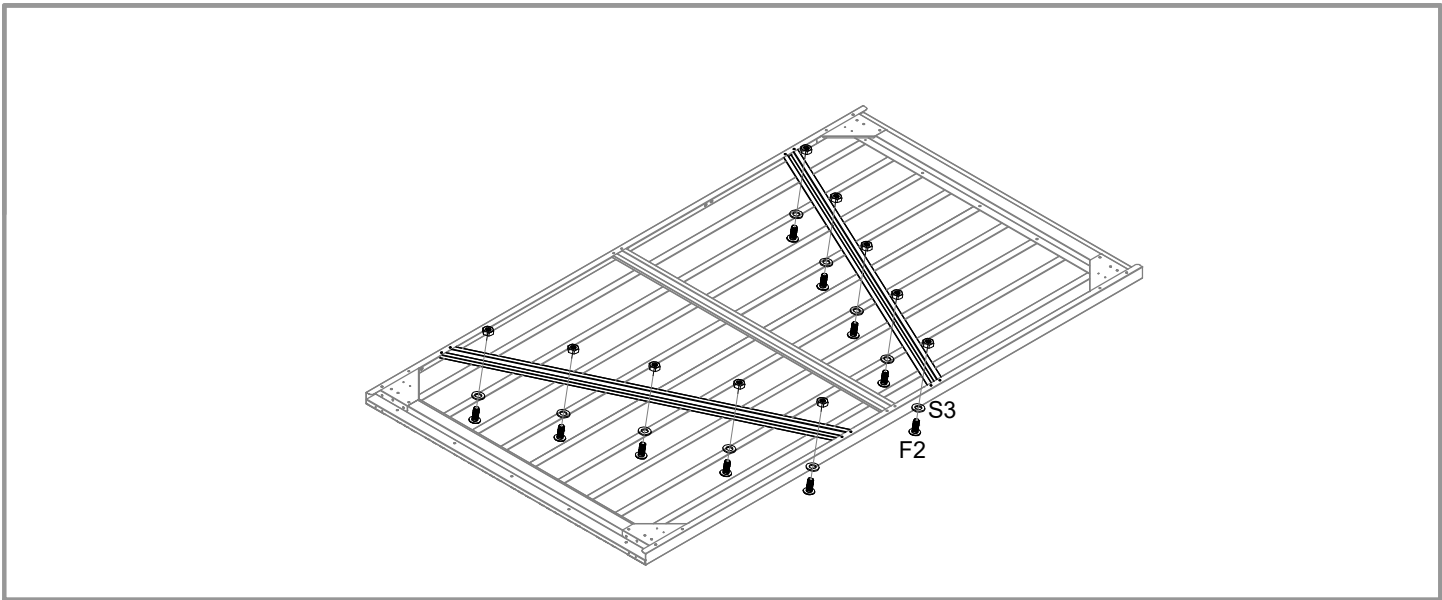



42		2
30		4

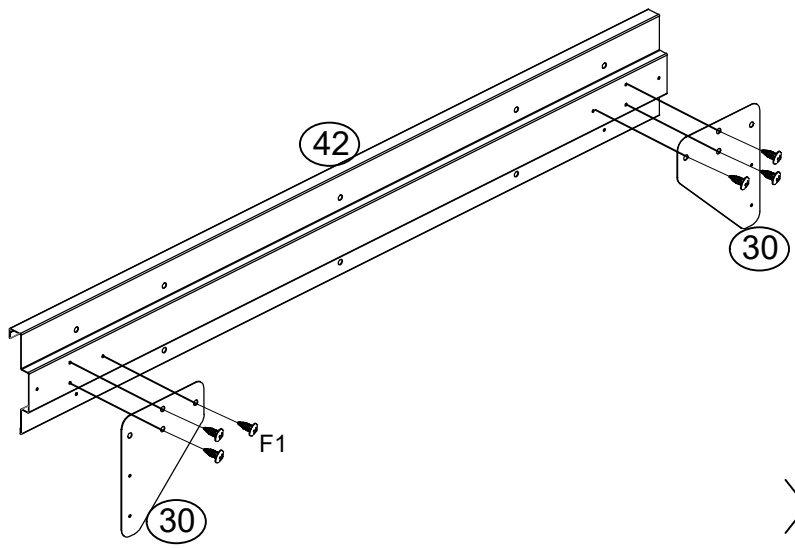

x2

D2		1
41		1
40		1
39		1

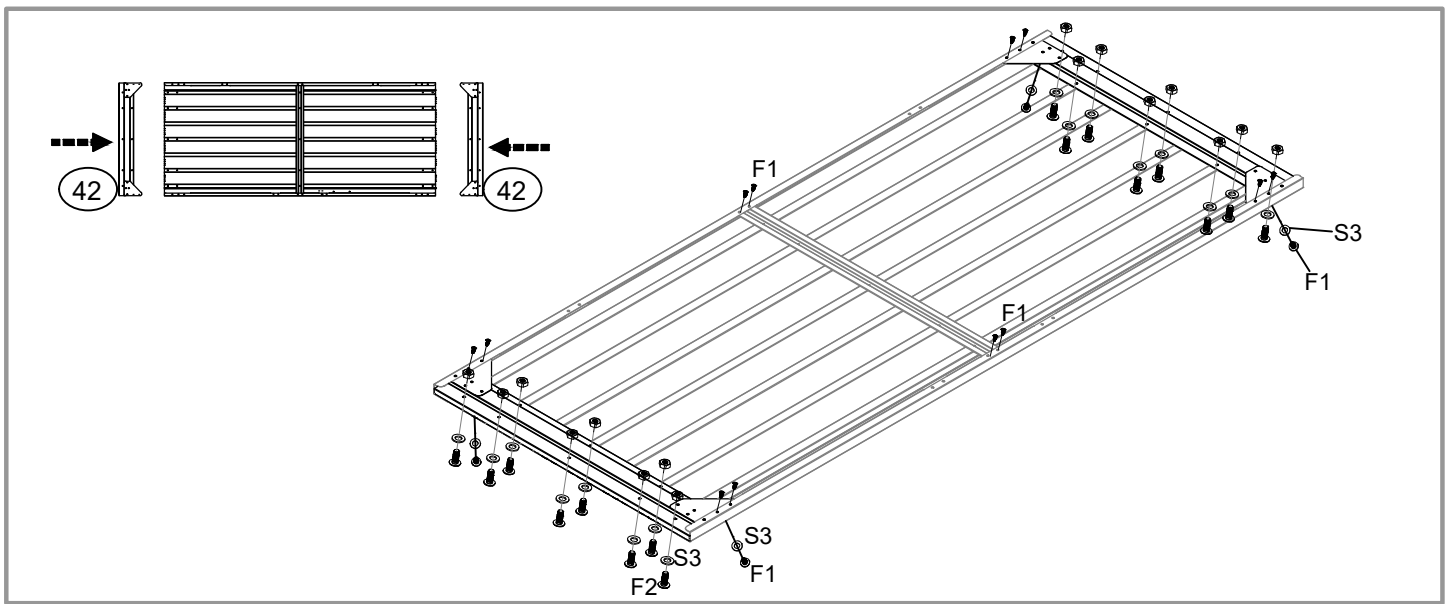
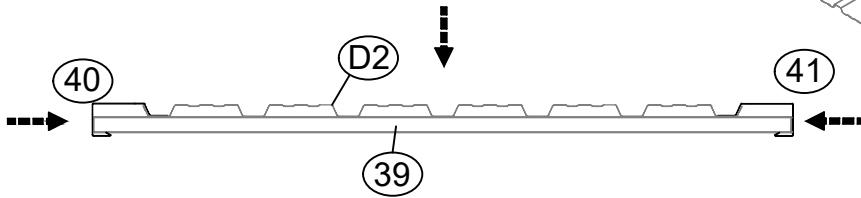
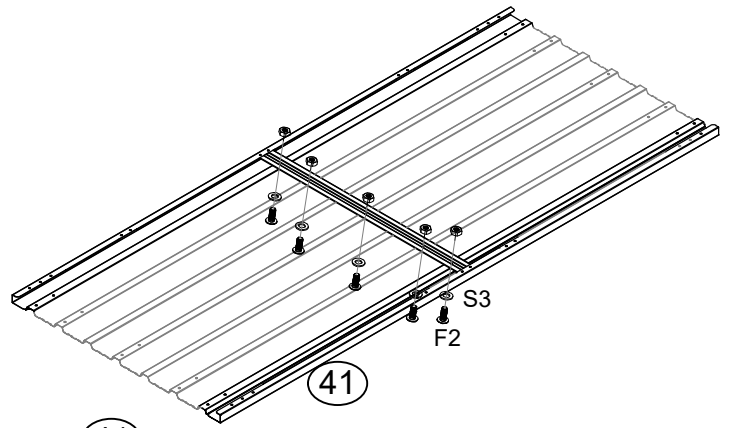

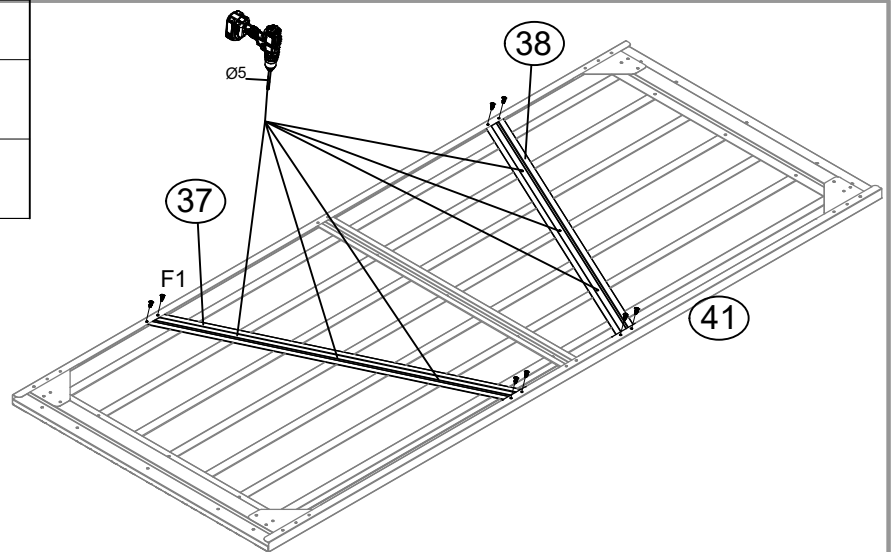

38		1
37		1

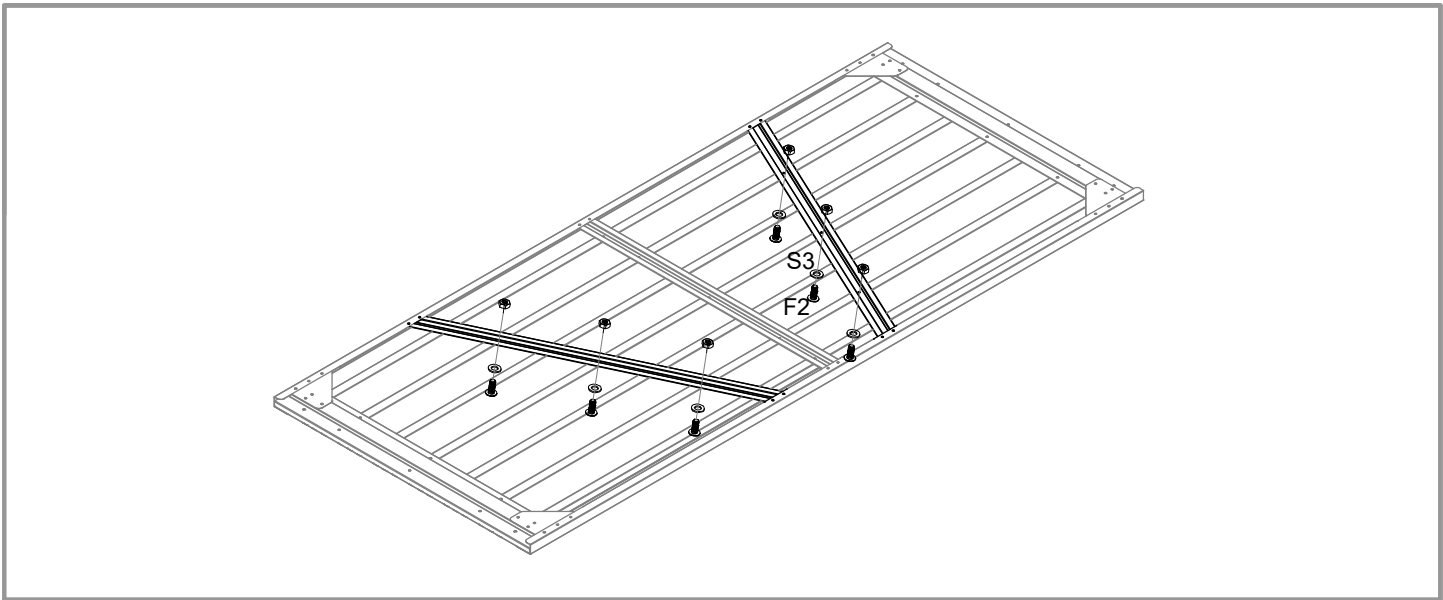



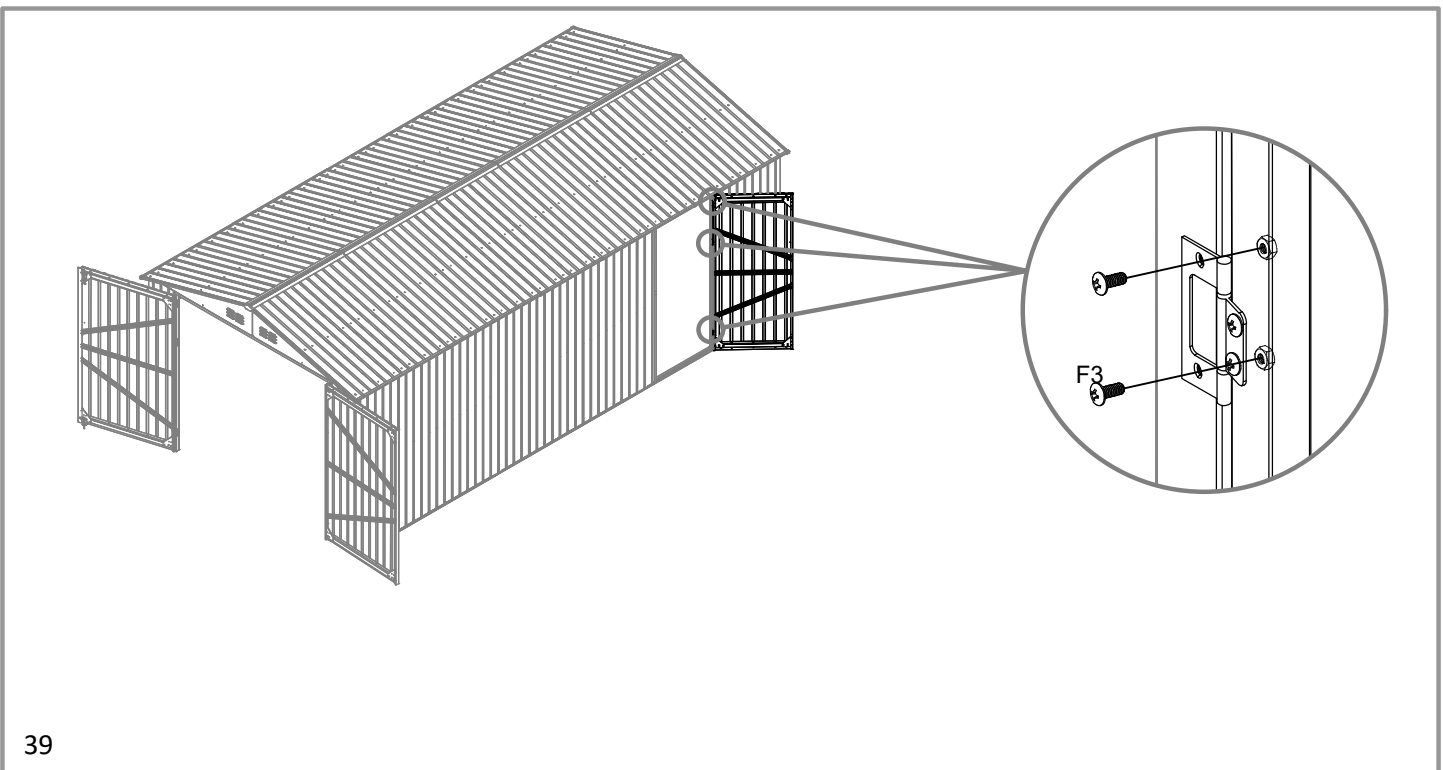
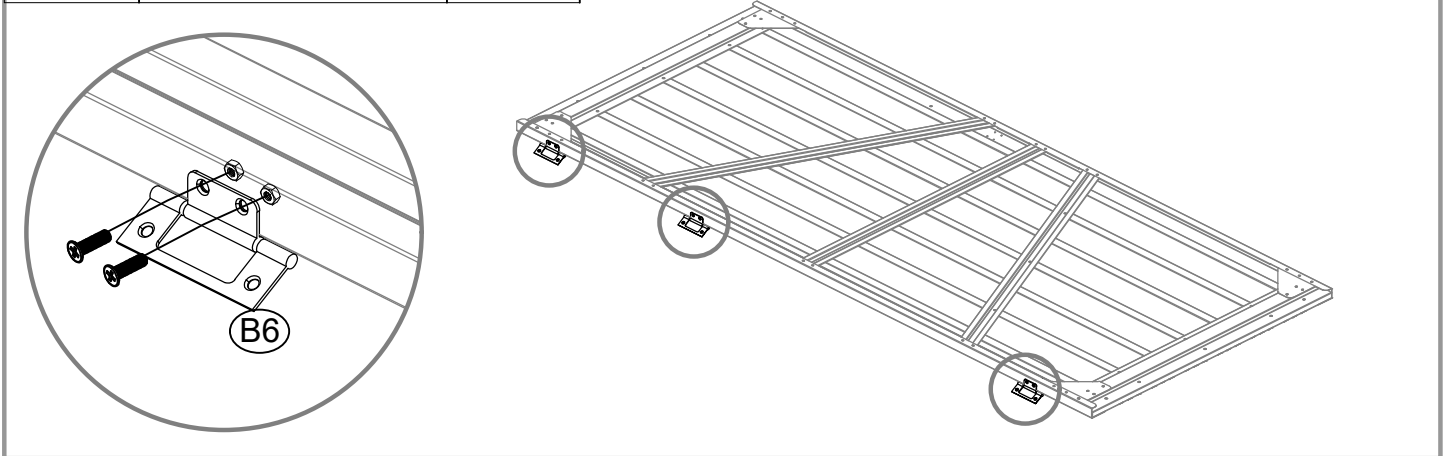



B6		3

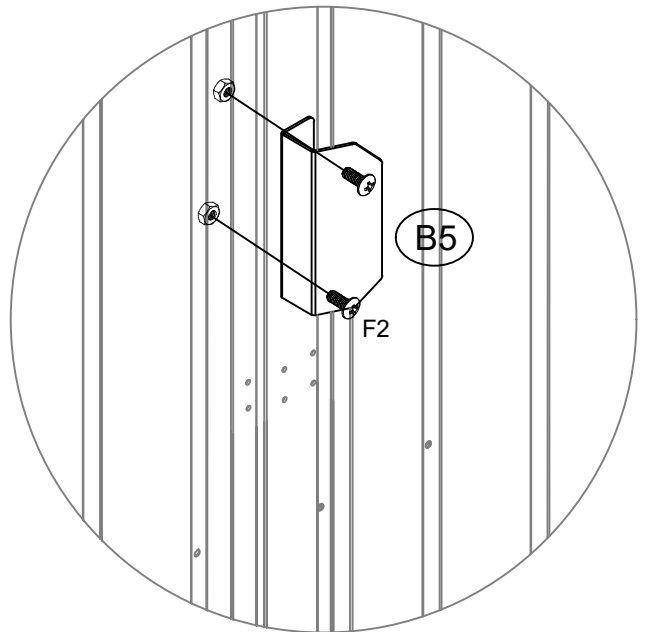
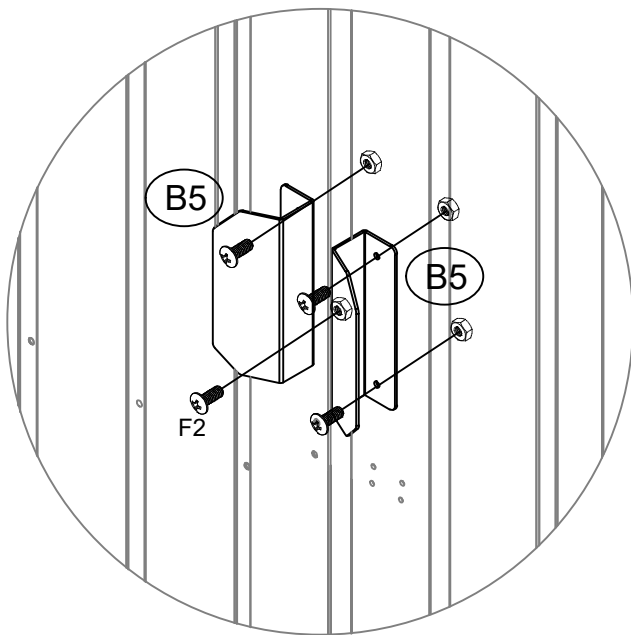
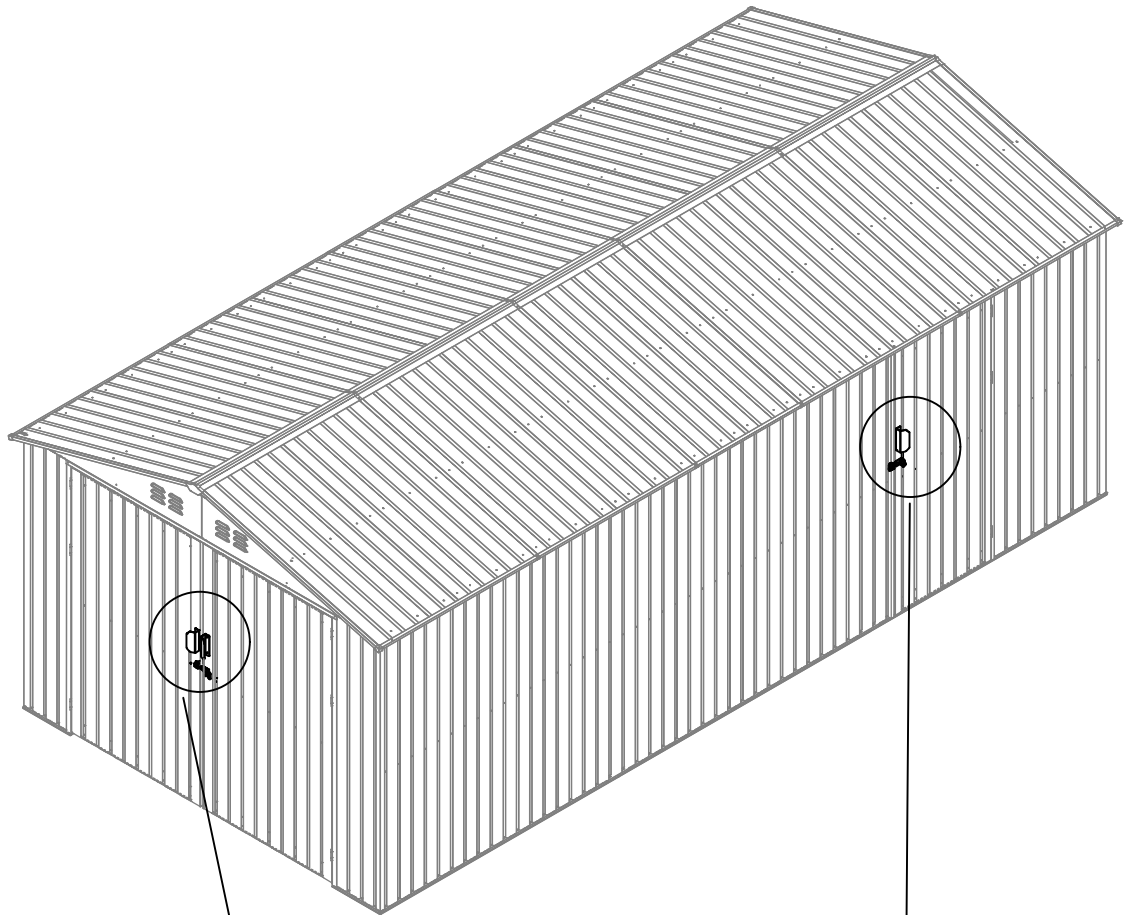

B5		3



H1		2
J5		1
J6		1

