

BESTBERG

GERMAN QUALITY

DE Bioklimatische Pergola aus Aluminium
EN Aluminium bioclimatic pergola
CZ Hliníková bioklimatická pergola
SK Hliníková bioklimatická pergola
PL Pergola bioklimatyczna aluminiowa
HU Alumínium bioklimatikus pergola
RO Pergolă bioclimatică din aluminiu

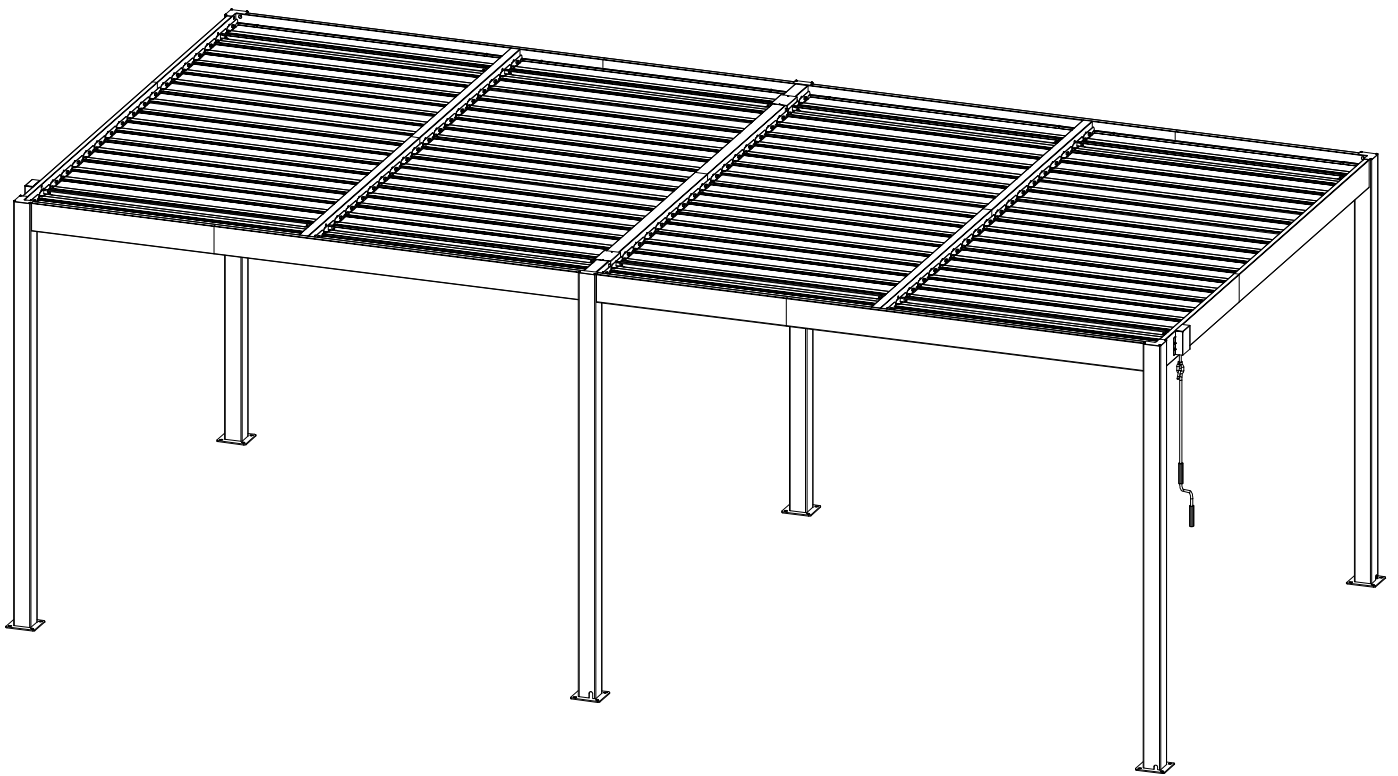

BBP-18G
6x3.04x2.18m

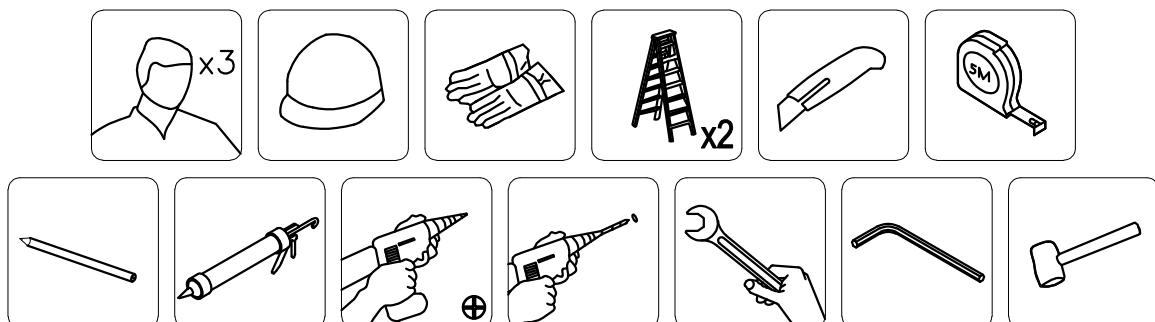

DE Wichtige Informationen:

Bitte lesen Sie diese Montageanleitung, bevor Sie mit der Montage beginnen.

- Vergleichen Sie den Packungsinhalt mit der Stückliste.
- Wenn ein Teil fehlt, bauen Sie die Pergola nicht auf und wenden Sie sich an Ihren Lieferanten.
- Folgen Sie der Vorgehensweise in der Montageanleitung.
- Bewahren Sie die Montageanleitung zum späteren Nachschlagen auf.
- Tragen Sie während der Montage Schutzhandschuhe, Schutzbrille und Arbeitsschuhe. Beachten Sie die allgemeinen Arbeitssicherheitshinweise.
- Beginnen Sie nicht bei Wind oder Regen mit der Montage.
- Seien Sie in großen Höhen besonders vorsichtig. Halten Sie einen Sicherheitsabstand zu Stromleitungen oberhalb der Pergola ein.
- Erlauben Sie Kindern nicht, sich auf der Baustelle aufzuhalten. Erlauben Sie ihnen nicht, mit Teilen und Zubehör zu spielen.
- Die Pergola muss auf einer ebenen Fläche aufgestellt werden.
- Die Pergola darf keinen starken Windböen ausgesetzt werden.
- Beginnen Sie nicht mit dem Aufbau der Pergola, wenn Sie sich unwohl fühlen oder unter dem Einfluss von Alkohol oder anderen Mitteln stehen.
- Befindet sich die Pergola neben dem Haus, muss verhindert werden, dass Schnee vom Dach auf die Pergola fällt!
- Die Pergola muss immer mit Füßen fest im Boden verankert werden!
- Nutzen Sie die vorgebohrten Löcher im Metallsockel, um die Pergola zu verankern.
- Bei Schneefall müssen die Lamellen geöffnet sein! Sollten die Lamellen vereist sein, dürfen diese nicht bewegt werden.
- Achten Sie darauf, dass kein Schmutz, beispielsweise Blätter, auf den Lamellen zurückbleibt. Es ist notwendig zu reinigen Lamellenmechanismus um Beschädigungen zu vermeiden. Kontrollieren Sie regelmäßig den festen Sitz aller Schrauben.
- Verwenden Sie zur Reinigung ausschließlich nicht scheuernde Reinigungsmittel. Verwenden Sie zur Reinigung keine Lösungsmittel. Verwenden Sie zur Reinigung beispielsweise eine milde Reinigungslösung und ein Tuch.
- Wir empfehlen, die Pergola nur an Orten aufzustellen, die keinem starken Wind oder Windböen ausgesetzt sind. Auf keinen Fall sollte eine Pergola auf freiem Gelände errichtet werden. dem Wind ausgesetzt.
- Die Pergola muss immer im ausreichend festen Untergrund verankert werden! Andernfalls besteht die Gefahr einer Beschädigung des Gerätes, einer Beschädigung fremden Eigentums oder einer gesundheitlichen Schädigung bei starkem Wind! Verankerung im Fundament oder auf ausreichend großen Untergründen.
- Für eine problemlose Montage sind 3 Personen erforderlich.
- Überprüfen Sie während der Montage regelmäßig, ob alle Maße und Winkel korrekt sind.
- Jegliche Veränderung der Pergola ist untersagt.
- Das Dach der Pergola ist nicht begehbar! Nicht auf das Dach der Pergola klettern! Nichts an die Lamellen hängen!
- Für Schäden an der Pergola oder sonstige Schäden, die durch Witterungseinflüsse wie starke Windböen, Überschwemmung, Hagel, schwere Stürme etc. entstehen, übernimmt der Hersteller keine Haftung. In einem solchen Fall ist es notwendig, sich an Ihre Versicherung zu wenden.

EN Important information:

Read these assembly instructions before starting assembly.

- Check the contents of the package against the parts list.
- If any part is missing, do not assemble the pergola and contact your supplier.
- Follow the assembly instructions.
- Save the assembly instructions for future reference.
- Wear protective gloves, goggles and work shoes during assembly. Follow general work safety instructions.
- Do not start assembly in windy or rainy weather.
- Be especially careful at heights. Keep a safe distance from any electrical lines above the pergola.
- Do not allow children to move around the construction site. Do not allow them to play with the parts and accessories.
- The pergola must be placed on a flat surface.
- The pergola must not be exposed to strong gusts of wind.
- Do not start assembling the pergola when you are feeling unwell or under the influence of alcohol or other substances.
- If the pergola is to be built next to the house, it is necessary to prevent snow from falling from the roof onto the pergola!
- The pergola must always be firmly anchored to the ground using the feet!
- To anchor the pergola, use the pre-drilled holes in the metal foot.
- The slats must be open during snowfall! Do not move the slats if they are covered with ice.
- Make sure that no dirt such as leaves remains on the slats. The slat mechanism must be cleaned to prevent damage. Regularly check the tightness of all screws.
- Use only non-abrasive cleaning agents for cleaning. Do not use solvents for cleaning. For cleaning, use, for example, a mild detergent solution and a cloth.
- We recommend placing the pergola exclusively in places that are not exposed to strong winds or gusts of wind. Never place the pergola in open areas in a place exposed to wind.
- The pergola must always be anchored to the ground that is sufficiently firm! Otherwise, in strong winds, there is a risk of damage to the pergola, damage to other people's property, or injury to health! Anchor it to the foundation or sufficiently large feet.
- 3 people are needed for trouble-free assembly.
- During assembly, regularly check that all dimensions and angles are correct.
- Any modification of the pergola is prohibited.
- The pergola roof is not walkable! Do not climb onto the pergola roof! Do not hang anything from the slats!
- The manufacturer is not liable for damage to the pergola or other damage caused by weather conditions such as strong gusts of wind, flood, hail, severe storms, etc. In such a case, you must contact your insurance company.

CZ Důležité informace

- Před začátkem montáže si přečtěte tento montážní návod.
 - Zkontrolujte obsah balení podle seznamu dílů.
 - Pokud vám nějaký díl chybí, pergolu nestavte a kontaktujte svého dodavatele.
 - Držte se postupu v montážním návodu.
 - Montážní návod si uložte pro budoucí použití.
-
- Během montáže používejte ochranné rukavice, brýle a pracovní obuv. Dodržujte všeobecné pracovní bezpečnostní pokyny.
 - Nezačínejte montáž při větrném a deštivém počasí.
 - Ve výškách si počínejte obzvláště opatrně. Dodržte bezpečnou vzdálenost od případného elektrického vedení nad pergolou.
 - Nedovolte dětem, aby se pohybovali v místě stavby. Nedovolte jim hrát si se součástmi a příslušenstvím.
 - Pergola musí být umístěna na rovném povrchu.
 - Pergola nesmí být vystavena silným poryvům větru.
 - Nezačínejte s montáží pergoly v době, kdy se necítíte dobře, nebo jste pod vlivem alkoholu či jiných látek.
 - Pokud bude stát pergola u domu, je nutné zabránit pádu sněhu ze střechy na pergolu!
 - Pergola musí být vždy pevně přikotvena k zemi pomocí patek!
-
- Pro ukotvení pergoly použijte předvrtané díry v kovové patce.
 - Lamely musí být při sněžení otevřené! Pokud jsou lamely pokryté ledem nepohybujte jimi.
 - Dbejte, aby se na lamelách neudržovaly nečistoty jako například listí. Je nutné čistit mechanismus lamel, aby se předešlo poškození. Pravidelně kontrolujte utažení všech šroubů.
 - K čištění používejte pouze neabrazivní čisticí prostředky. Nepoužívejte k čištění rozpouštědla. K čištění používejte například jemný saponátový roztok a hadřík.
-
- Pergolu doporučujeme umístit výhradně na místech, která nejsou vystavena většímu větru nebo nárazům větru. Rozhodně nestavte pergolu na volně otevřených prostranstvích na místě vystaveném větru.
 - Pergolu je nutné vždy ukotvit k zemi která je dostatečně pevná! Jinak hrozí při silném větru její poškození, poškození majetku druhých osob, nebo utrpení škody na zdraví! Kotvěte do základů, nebo dostatečně velkých patek.
 - Pro bezproblémovou montáž jsou potřeba 3 osoby.
 - Při montáži pravidelně kontrolujte, zda jsou všechny rozměry a úhly správné.
 - Je zakázána jakákoliv úprava pergoly.
 - Střecha pergoly není pochozí! Nevstupujte na střechu pergoly! Za lamely nic nezavěšujte!
 - Výrobce neručí za škody na pergole nebo za jiné škody způsobené povětrnostními vlivy jako silné poryvy větru, povodeň, krupobití, silná bouře apod. V takovém případě je nutné kontaktovat svou pojišťovací společnost.

SK Dôležité informácie:

Pred začiatkom montáže si prečítajte tento montážny návod.

- Skontrolujte obsah balenia podľa zoznamu dielov.
- Pokiaľ vám nejaký diel chýba, pergolu nestavajte a kontaktujte svojho dodávateľa.
- Držte sa postupu v montážnom návode.
- Montážny návod si uložte pre budúce použitie.
- Počas montáže používajte ochranné rukavice, okuliare a pracovnú obuv. Dodržujte všeobecné pracovné bezpečnostné pokyny.
- Nezačínajte montáž pri veternom a daždivom počasí.
- Vo výškach si počínajte obzvlášť opatrne. Dodržte bezpečnú vzdialenosť od prípadného elektrického vedenia nad pergolou.
- Nedovoľte deťom, aby sa pohybovali v mieste stavby. Nedovoľte im hrať sa so súčasťami a príslušenstvom.
- Pergola musí byť umiestnená na rovnom povrchu.
- Pergola nesmie byť vystavená silným poryvom vetra.
- Nezačínajte s montážou pergoly v čase, keď sa necítite dobre, alebo ste pod vplyvom alkoholu či iných látok.
- Pokiaľ bude stáť pergola pri dome, je nutné zabrániť pádu snehu zo strechy na pergolu!
- Pergola musí byť vždy pevne prikotvená k zemi pomocou pätiiek!
- Na ukotvenie pergoly použite predvŕtané diery v kovovej pätkke.
- Lamely musia byť pri snežení otvorené! Pokiaľ sú lamely pokryté ľadom nepohybujte nimi.
- Dbajte, aby sa na lamelách neudržovali nečistoty ako napríklad lístie. Je nutné čistiť mechanizmus lamiel, aby sa predišlo poškodeniu. Pravidelne kontrolujte utiahnutie všetkých skrutiek.
- Na čistenie používajte iba neabrazívne čistiace prostriedky. Nepoužívajte na čistenie rozpúšťadla. Na čistenie používajte napríklad jemný saponátový roztok a handričku.
- Pergolu odporúčame umiestniť výhradne na miestach, ktoré nie sú vystavené väčšiemu vetru alebo nárazom vetra. Rozhodne nestavajte pergolu na voľne otvorených priestranstvách na mieste vystavenom vetru.
- Pergolu je nutné vždy ukotviť k zemi, ktorá je dostatočne pevná! Inak hrozí pri silnom vetre jej poškodenie, poškodenie majetku druhých osôb, alebo utrpenie škody na zdraví! Kotvite do základov, alebo dostatočne veľkých pätiiek.
- Na bezproblémovú montáž sú potrebné 3 osoby.
- Pri montáži pravidelne kontrolujte, či sú všetky rozmery a uhly správne.
- Je zakázaná akákoľvek úprava pergoly.
- Strecha pergoly nie je pochôdzna! Nevstupujte na strechu pergoly! Za lamely nič nevešajte!
- Výrobca neručí za škody na pergole alebo za iné škody spôsobené poveternostnými vplyvmi ako silné poryvy vetra, povodeň, krupobitie, silná búrka a pod. V takom prípade je nutné kontaktovať svoju poisťovaciu spoločnosť.

PL Ważne informacje

- Przed rozpoczęciem montażu należy przeczytać instrukcję montażu.
- Sprawdź zawartość opakowania z listą części.
- Jeśli brakuje jakichkolwiek części, nie montuj pergoli i skontaktuj się z dostawcą.
- Postępuj zgodnie z instrukcją montażu.
- Zachowaj instrukcję montażu do wykorzystania w przyszłości.
- Podczas montażu należy nosić rękawice ochronne, okulary ochronne i obuwie robocze. Należy przestrzegać ogólnych zasad bezpieczeństwa pracy.
- Nie rozpoczynaj montażu przy wietrznej lub deszczowej pogodzie.
- Zachowaj szczególną ostrożność na wysokościach. Zachowaj bezpieczną odległość od linii elektrycznych nad pergolą.
- Nie pozwalaj dzieciom poruszać się po placu budowy. Nie pozwól im bawić się częściami i akcesoriami.
- Pergolę należy ustawić na płaskiej powierzchni.
- Pergola nie może być narażona na silne podmuchy wiatru.
- Nie rozpoczynaj montażu pergoli, jeśli źle się czujesz lub jesteś pod wpływem alkoholu lub innych substancji.
- Jeśli pergola ma być zbudowana obok domu, należy zapobiec zsuwaniu się śniegu z dachu na pergolę!
- Pergola musi być zawsze mocno zakotwiczona do podłoża za pomocą nóżek!
- Do zakotwiczenia pergoli należy wykorzystać wstępnie nawiercone otwory w metalowej nóżce.
- Lamelle muszą być otwarte podczas opadów śniegu! Nie należy ich przesuwać, jeśli są pokryte lodem.
- Należy upewnić się, że na lamelach nie pozostały żadne zabrudzenia, takie jak liście. Mechanizm lamel należy czyścić, aby zapobiec jego uszkodzeniu. Regularnie sprawdzaj dokręcenie wszystkich śrub.
- Do czyszczenia należy używać wyłącznie nieściernych środków czyszczących. Nie należy stosować rozpuszczalników. Do czyszczenia należy używać np. łagodnego roztworu detergentu i ściereczki.
- Zalecamy ustawianie pergoli wyłącznie w miejscach, które nie są narażone na silne wiatry lub podmuchy wiatru. Nie należy ustawiać pergoli na otwartej przestrzeni, w miejscu narażonym na działanie wiatru.
- Pergola musi być zawsze zakotwiczona do odpowiednio twardego podłoża! W przeciwnym razie, przy silnym wietrze, istnieje ryzyko jej uszkodzenia, uszkodzenia mienia osób trzecich lub uszczerbku na zdrowiu! Należy zakotwaczyć pergolę do fundamentu lub odpowiednio dużych stóp.
- Do bezproblemowego montażu potrzebne są 3 osoby.
- Podczas montażu należy regularnie sprawdzać poprawność wszystkich wymiarów i kątów.
- Wszelkie modyfikacje pergoli są zabronione.
- Dach pergoli nie nadaje się do chodzenia! Nie należy wchodzić na dach pergoli! Nie należy niczego wieszać na listwach!
- Producent nie ponosi odpowiedzialności za uszkodzenia pergoli ani inne szkody spowodowane warunkami atmosferycznymi, takimi jak silne porywy wiatru, powódzie, grad, gwałtowne burze itp. W takim przypadku należy skontaktować się z ubezpieczycielem.

HU Fontos információk

- Az összeszerelés megkezdése előtt olvassa el az összeszerelési utasításokat.
- Ellenőrizze a csomag tartalmát az alkatrészslista alapján.
- Ha hiányzik bármilyen alkatrész, ne szerelje össze a pergolat, és vegye fel a kapcsolatot a szállítójával.
- Kövesse az összeszerelési utasításokat.
- Őrizze meg az összeszerelési utasításokat későbbi felhasználás céljából.
- Összeszerelés közben viseljen védőkesztyűt, védőszemüveget és munkacipőt. Kövesse az általános munkavédelmi utasításokat.
- Ne kezdje el az összeszerelést szeles vagy esős időben.
- Legyen különösen óvatos magasban. Tartson biztonságos távolságot a pergola feletti elektromos vezetékektől.
- Ne engedje, hogy gyermekek mozogjanak az építési területen. Ne engedje, hogy játsszanak az alkatrészekkel és a tartozékokkal.
- A pergolat sík felületre kell helyezni.
- A pergolat nem szabad erős széllekeknek kitenni.
- Ne kezdje el a pergola összeszerelését, ha rosszul érzi magát, vagy alkohol vagy más szerek hatása alatt áll.
- Ha a pergolat a ház mellé építik, meg kell akadályozni, hogy a tetőről a pergolára essen a hó! • A pergolat mindig szilárdan kell rögzíteni a talajhoz a lábak segítségével!
- A pergola rögzítéséhez használja a fémláb előre fúrt lyukait.
- Havazáskor a léceknak nyitva kell lenniük! Ne mozgassa a léceket, ha jég borítja őket.
- Ügyeljen arra, hogy ne maradjon szennyeződés, például levelek a léceken. A lécmechanizmust meg kell tisztítani a sérülések elkerülése érdekében. Rendszeresen ellenőrizze az összes csavar meghúzását.
- A tisztításhoz csak nem súroló tisztítószerket használjon. Ne használjon oldószereket a tisztításhoz. Például enyhe mosószeres oldatot és rongyot használjon a tisztításhoz.
- Javasoljuk, hogy a pergolat csak olyan helyekre helyezze el, amelyek nincsenek kitéve erős szélnek vagy széllekeknek. Ne helyezze a pergolat nyílt, szélnek kitett helyre.
- A pergolat mindig kellően szilárd talajhoz kell rögzíteni! Ellenkező esetben erős szélben fennáll a pergola károsodásának, mások tulajdonában bekövetkező kárnak vagy egészségkárosodásnak a veszélye! Rögzítse az alaphoz vagy kellően nagy lábakhoz.
- A problémamentes összeszereléshez 3 ember szükséges.
- Összeszerelés közben rendszeresen ellenőrizze, hogy minden méret és szög megfelelő-e.
- A pergola bármilyen módosítása tilos.
- A pergola teteje nem járható! Ne másszon fel a pergola tetejére! Ne akasszon semmit a lécekre!
- A gyártó nem vállal felelősséget a pergola károsodásáért vagy az időjárási viszonyok, például erős széllekek, árvíz, jégeső, heves viharok stb. által okozott egyéb károkért. Ilyen esetben feltétlenül vegye fel a kapcsolatot a biztosítótársaságával.

RO Informații importante

- Citiți aceste instrucțiuni de asamblare înainte de a începe asamblarea.
- Verificați conținutul ambalajului cu lista de piese.
- Dacă lipsesc piese, nu asamblați pergola și contactați furnizorul.
- Urmați instrucțiunile de asamblare.
- Păstrați instrucțiunile de asamblare pentru referințe ulterioare.
- Purtați mănuși de protecție, ochelari de protecție și încălțăminte de lucru în timpul asamblării. Respectați instrucțiunile generale de siguranță la locul de muncă.
- Nu începeți asamblarea pe vreme de vânt sau ploaie.
- Fiți deosebit de atenți la înălțime. Păstrați o distanță sigură față de orice linii electrice de deasupra pergolei.
- Nu permiteți copiilor să se deplaseze în jurul șantierului. Nu le permiteți să se joace cu piesele și accesoriile.
- Pergola trebuie așezată pe o suprafață plană.
- Pergola nu trebuie expusă la rafale puternice de vânt.
- Nu începeți asamblarea pergolei atunci când vă simțiți rău sau sub influența alcoolului sau a altor substanțe.
- Dacă pergola urmează să fie construită lângă casă, este necesar să preveniți căderea zăpezii de pe acoperiș pe pergolă! • Pergola trebuie să fie întotdeauna ferm ancorată în sol folosind picioarele!
- Folosiți găurile pre-găurite din piciorul metalic pentru a ancora pergola.
- Lamelele trebuie să fie deschise în timpul ninsorilor! Nu mișcați lamelele dacă sunt acoperite cu gheață.
- Asigurați-vă că nu rămâne murdărie, cum ar fi frunze, pe lamele. Mecanismul lamelelor trebuie curățat pentru a preveni deteriorarea. Verificați periodic strângerea tuturor șuruburilor.
- Folosiți doar agenți de curățare neabrazivi pentru curățare. Nu utilizați solvenți pentru curățare. De exemplu, utilizați o soluție de detergent blând și o lavetă pentru curățare.
- Recomandăm ca pergola să fie amplasată numai în locuri care nu sunt expuse la vânturi puternice sau rafale de vânt. Nu amplasați pergola în zone deschise, într-un loc expus vântului.
- Pergola trebuie să fie întotdeauna ancorată în sol suficient de ferm! În caz contrar, în caz de vânturi puternice, există riscul de deteriorare a acesteia, de deteriorare a bunurilor altor persoane sau de vătămare a sănătății! Ancorați la fundație sau la picioare suficient de mari.
- Sunt necesare 3 persoane pentru un montaj fără probleme.
- În timpul montării, verificați periodic dacă toate dimensiunile și unghiurile sunt corecte.
- Orice modificare a pergolei este interzisă.
- Acoperișul pergolei nu este accesibil pietonal! Nu vă urcați pe acoperișul pergolei! Nu agățați nimic de lamele!
- Producătorul nu este răspunzător pentru deteriorarea pergolei sau alte daune cauzate de condițiile meteorologice, cum ar fi rafale puternice de vânt, inundații, grindină, furtuni puternice etc. Într-un astfel de caz, trebuie să contactați compania de asigurări.

600cm x 304cm x 218cm

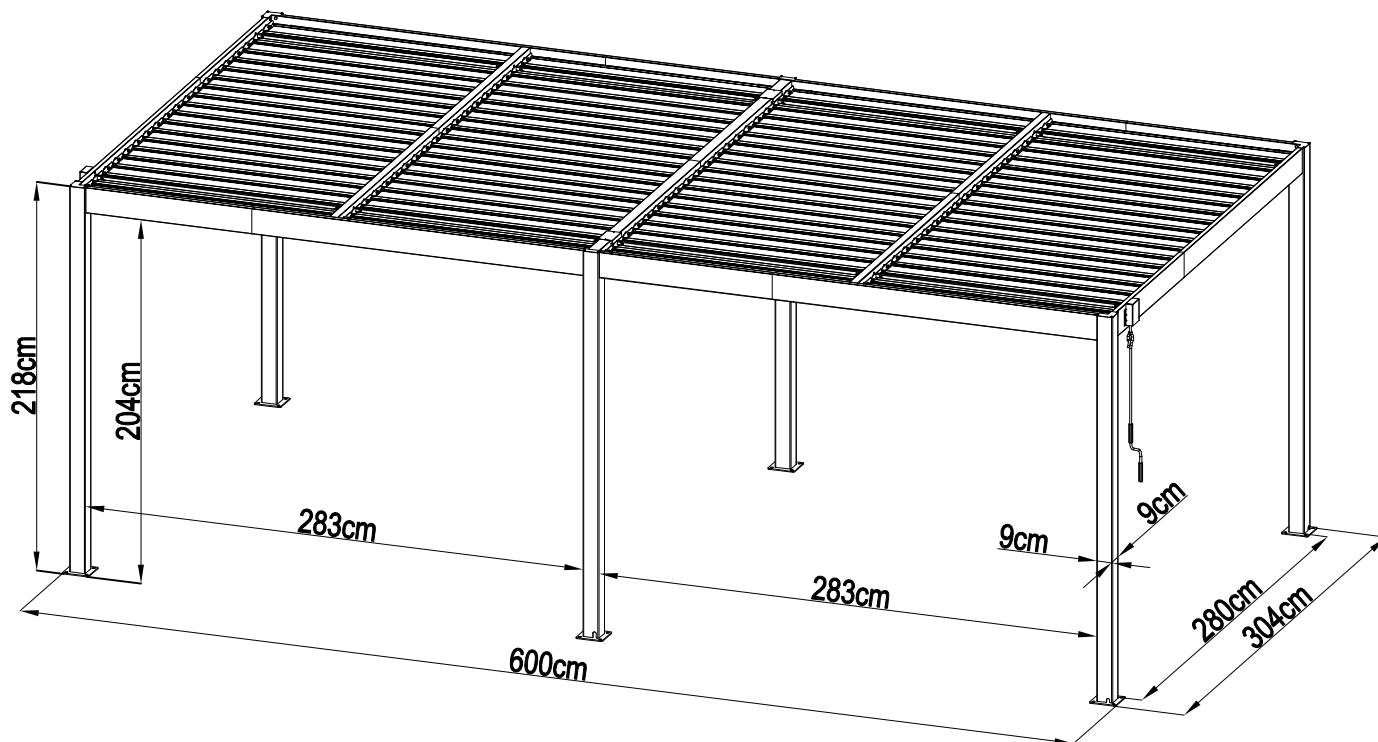

DE Erforderlicher Installationsbereich:

EN Area of installation requirement:

CZ Požadavky na oblast instalace:

SK Požiadavky na oblasť inštalácie:

PL Wymagania dotyczące obszaru instalacji:





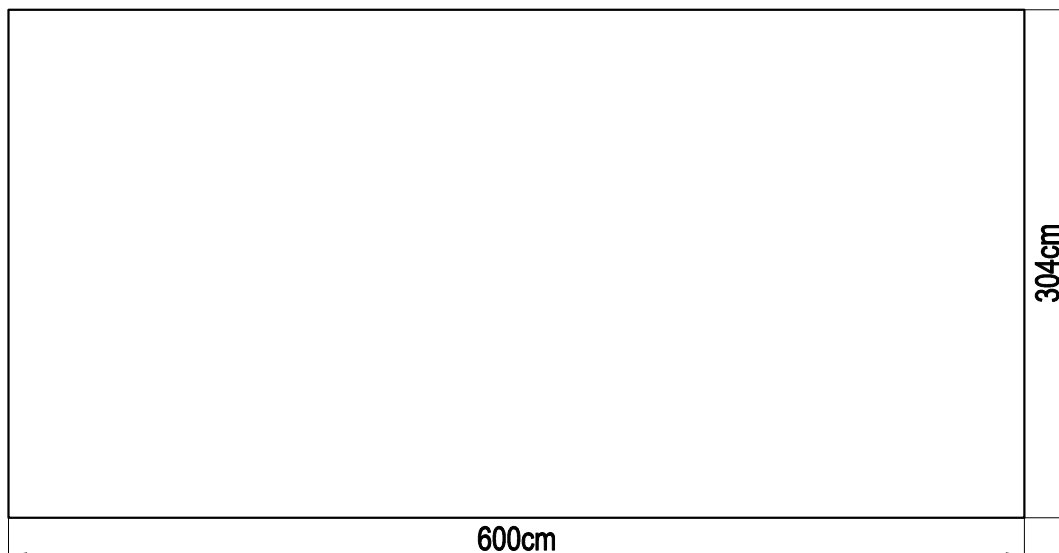

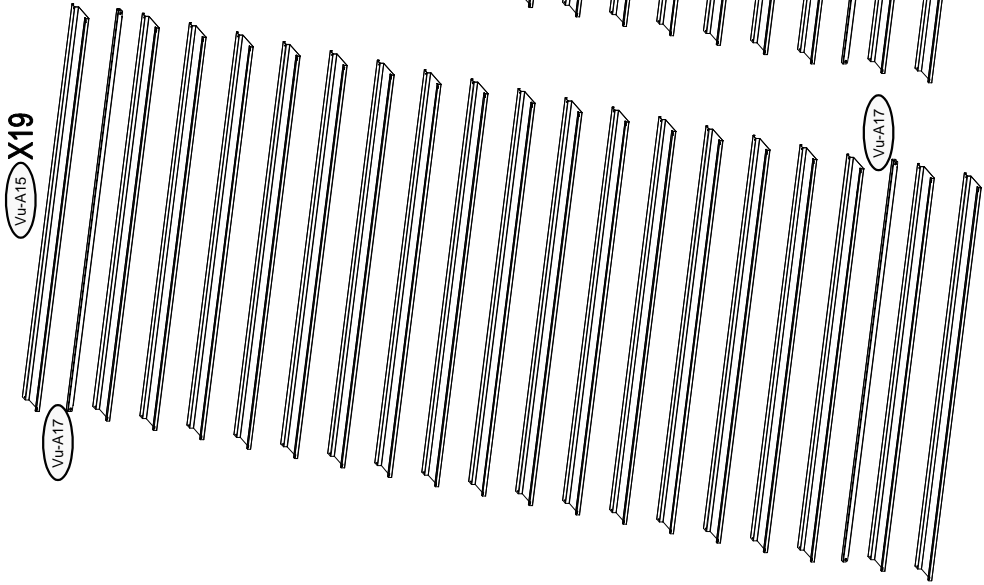
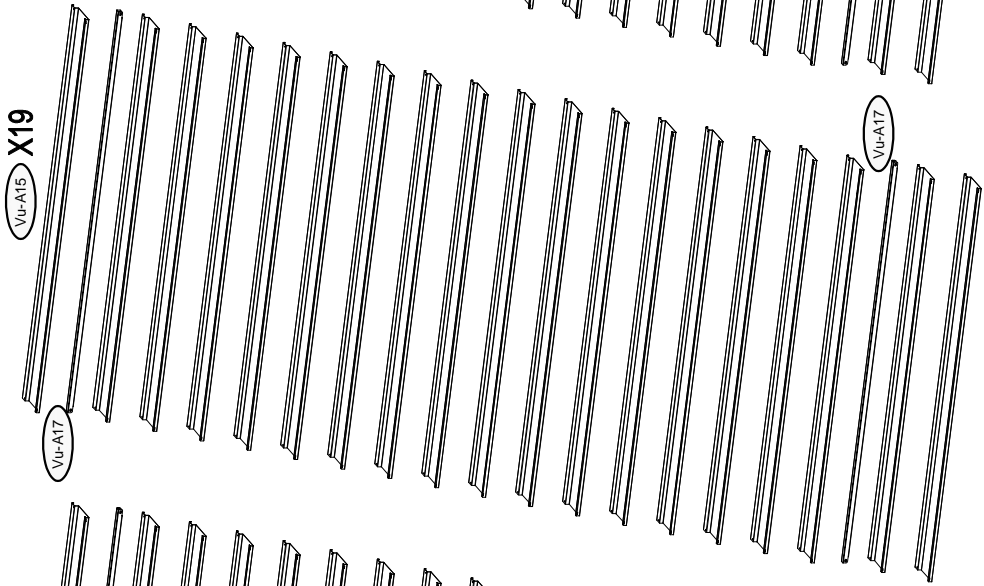
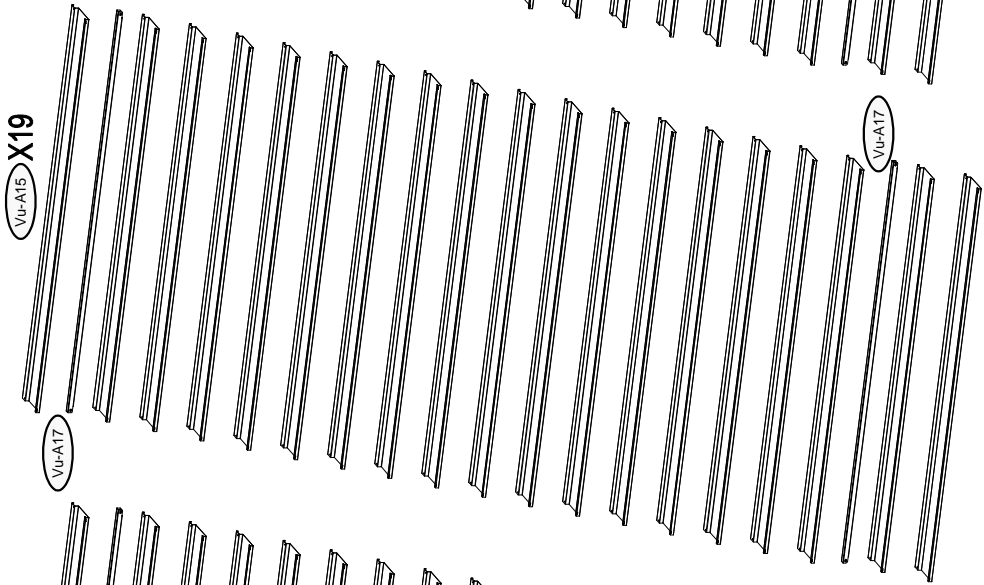
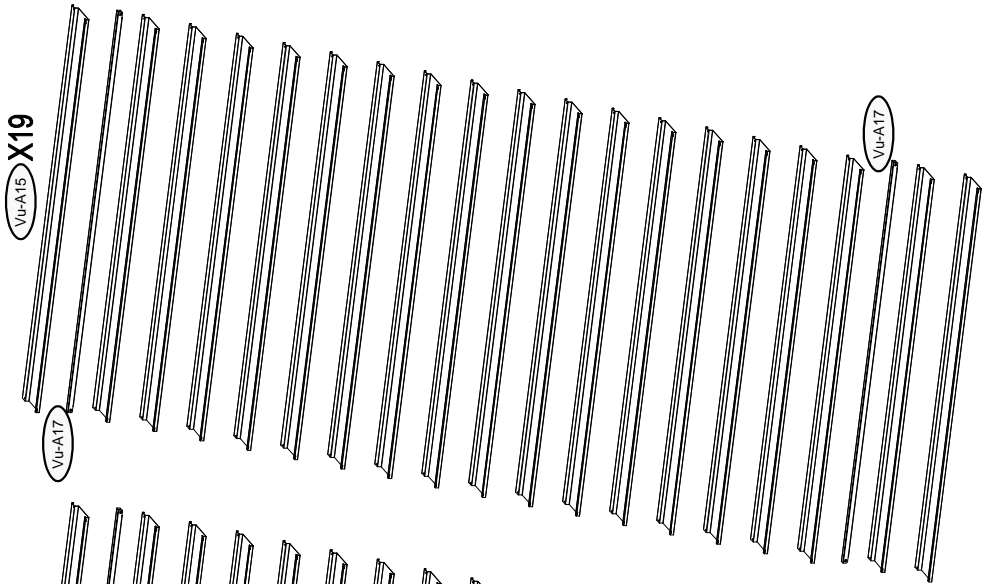

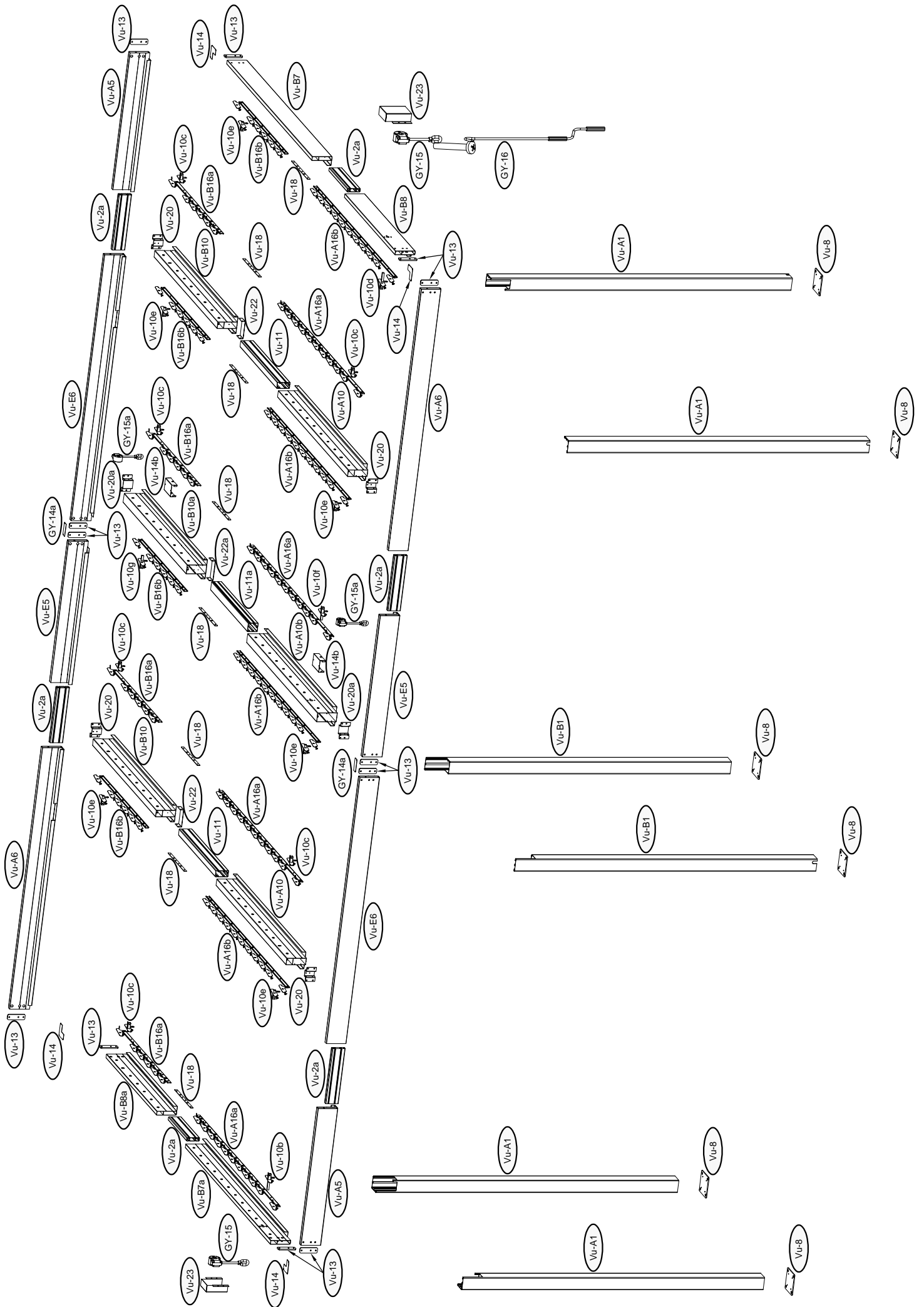



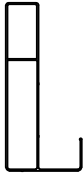
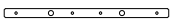







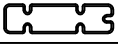



























HU Telepítési terület követelményei:

RO Cerințe privind zona de instalare:









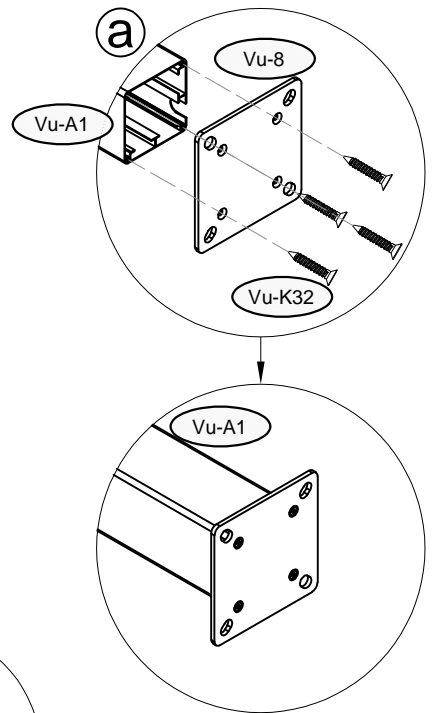
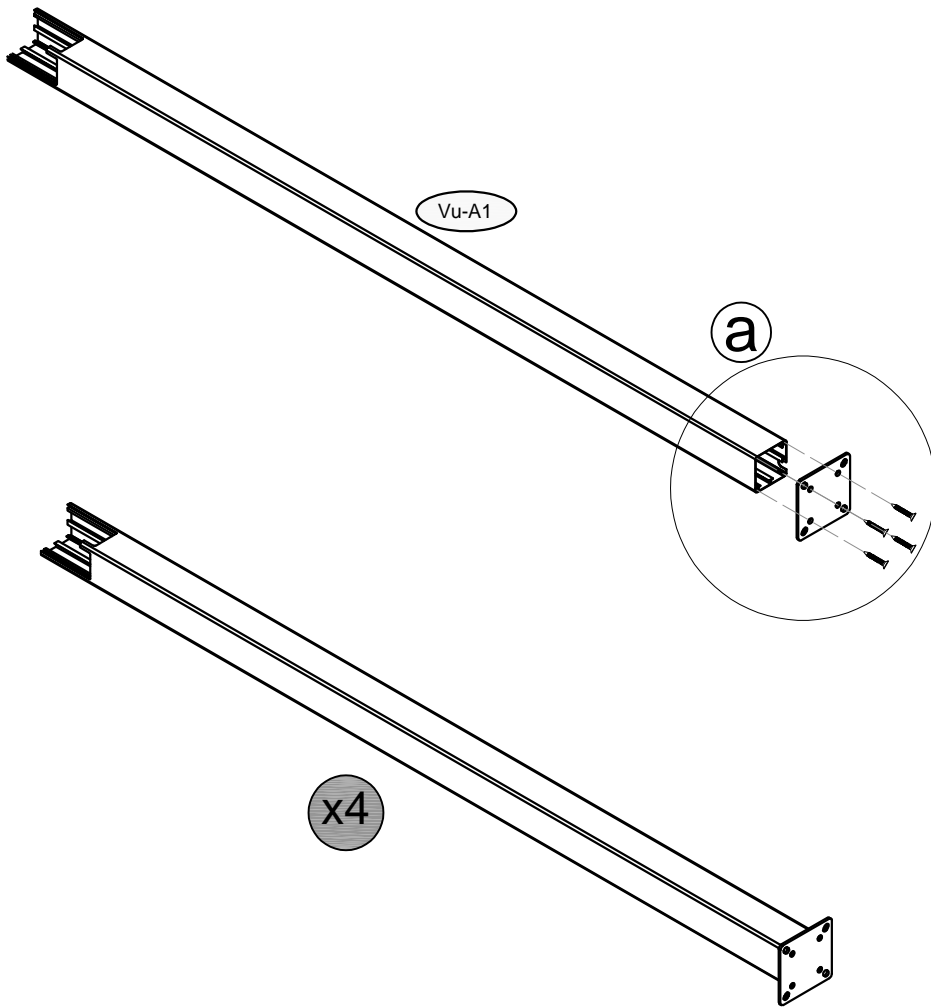

NO.	IMAGE	mm	QTY	NO.	IMAGE	mm	QTY
Vu-A1		2175	x4	Vu-14a			x2
Vu-B1		2175	x2	Vu-14b			x2
Vu-A5		994	x2	Vu-18			x8
Vu-A6		1900	x2	Vu-20			x4
Vu-E5		1027	x2	Vu-20a			x2
Vu-E6		1933	x2	Vu-22			x2
Vu-B7		1855	x1	Vu-22a			x1
Vu-B7a		1855	x1	Vu-23			x2
Vu-B8		1100	x1	GY-15			x2
Vu-B8a		1100	x1	GY-15a			x2
Vu-2a			400	x6	GY-16		
Vu-A10		1525	x2	Vu-21			x136
Vu-B10		1374	x2	Vu-26			x152
Vu-A10b		1525	x1	Vu-K30		M8x10	x36
Vu-B10a		1374	x1	Vu-K31		M8	x36
Vu-11		800	x2	Vu-K32		ST5x35	x24
Vu-11a		800	x1	Vu-K33		ST5x14	x16
Vu-A16a		1751.5	x4	Vu-K34		ST4.8x16	x222
Vu-A16b		1751.5	x4	Vu-K35		M5x15	x16
Vu-B16a		996.5	x4	Vu-K36		M5	x16
Vu-B16b		996.5	x4	Vu-K37		M6x25	x16
Vu-A17		1353	x8	Vu-K38		M6x40	x12
Vu-A15		1388	x76	Vu-K39		M6	x28
Vu-8			x6	Vu-K40		M6	x28
Vu-10b			x1	Vu-K41		M8x31	x136
Vu-10c			x6	Vu-K42		M4x10	x164
Vu-10d			x1	Vu-K43		M4x10	x32
Vu-10e			x6	Vu-K44		M4	x44
Vu-10f			x1	Vu-K45		M8x70	x24
Vu-10g			x1				
Vu-13			x12				
Vu-14			x4				

	 Vu-A1 x4	 Vu-8 x4	 Vu-K32 x16	
--	---	--	---	--

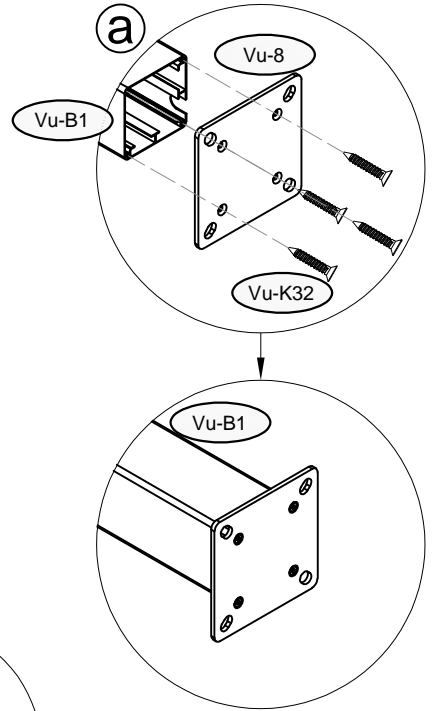
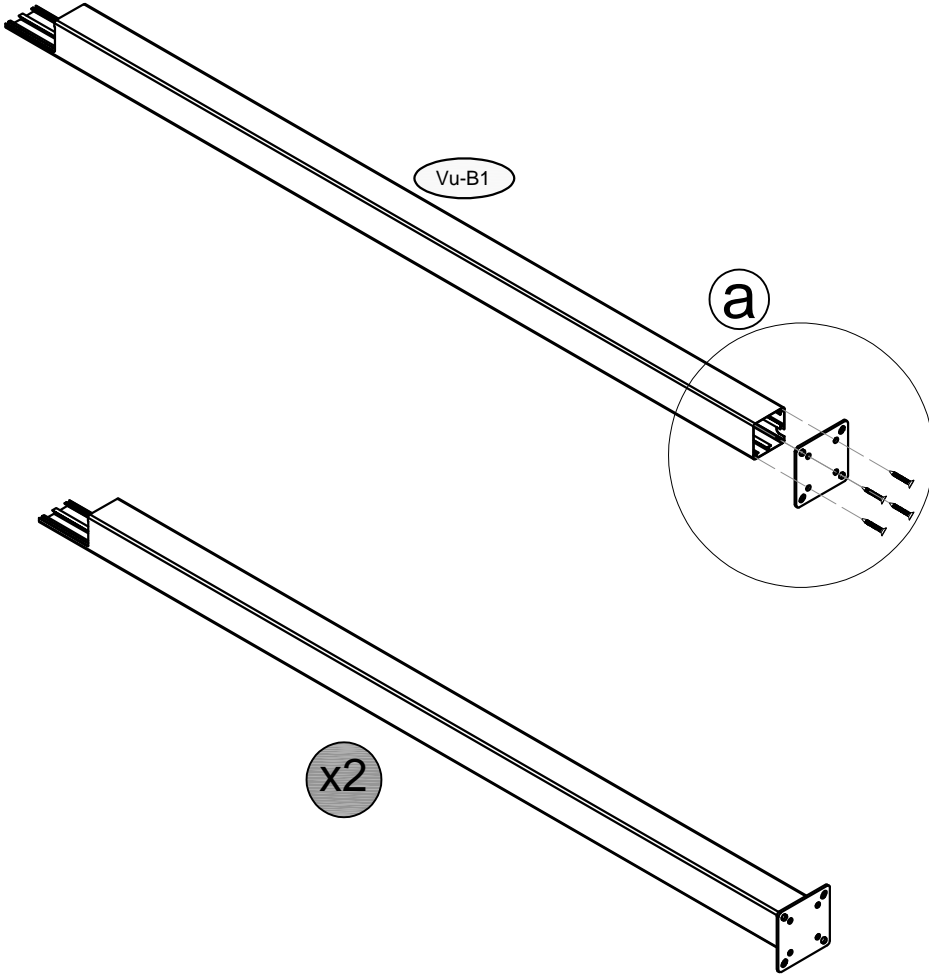



<p>2</p>	 <p>Vu-B1 x2</p>	 <p>Vu-8 x2</p>	 <p>Vu-K32 x8</p>	
-----------------	---	--	--	--



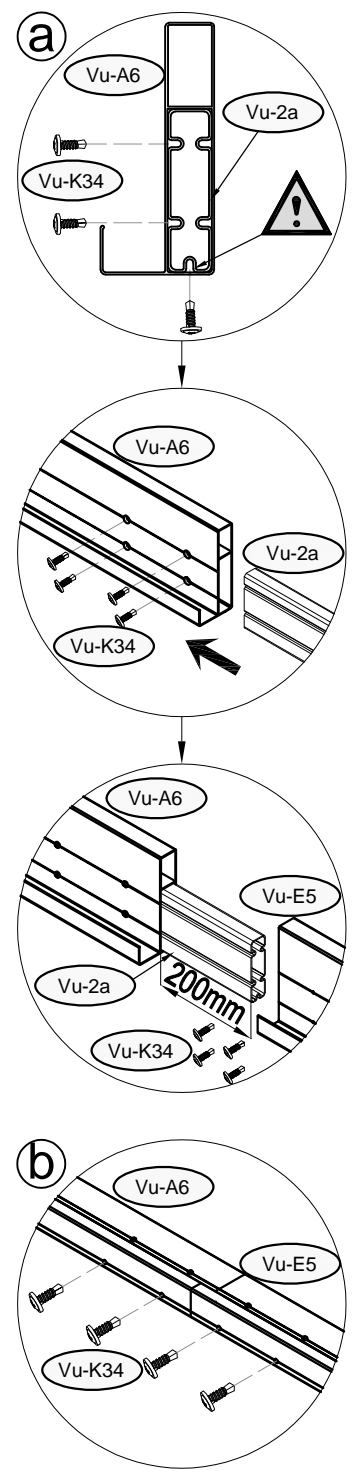
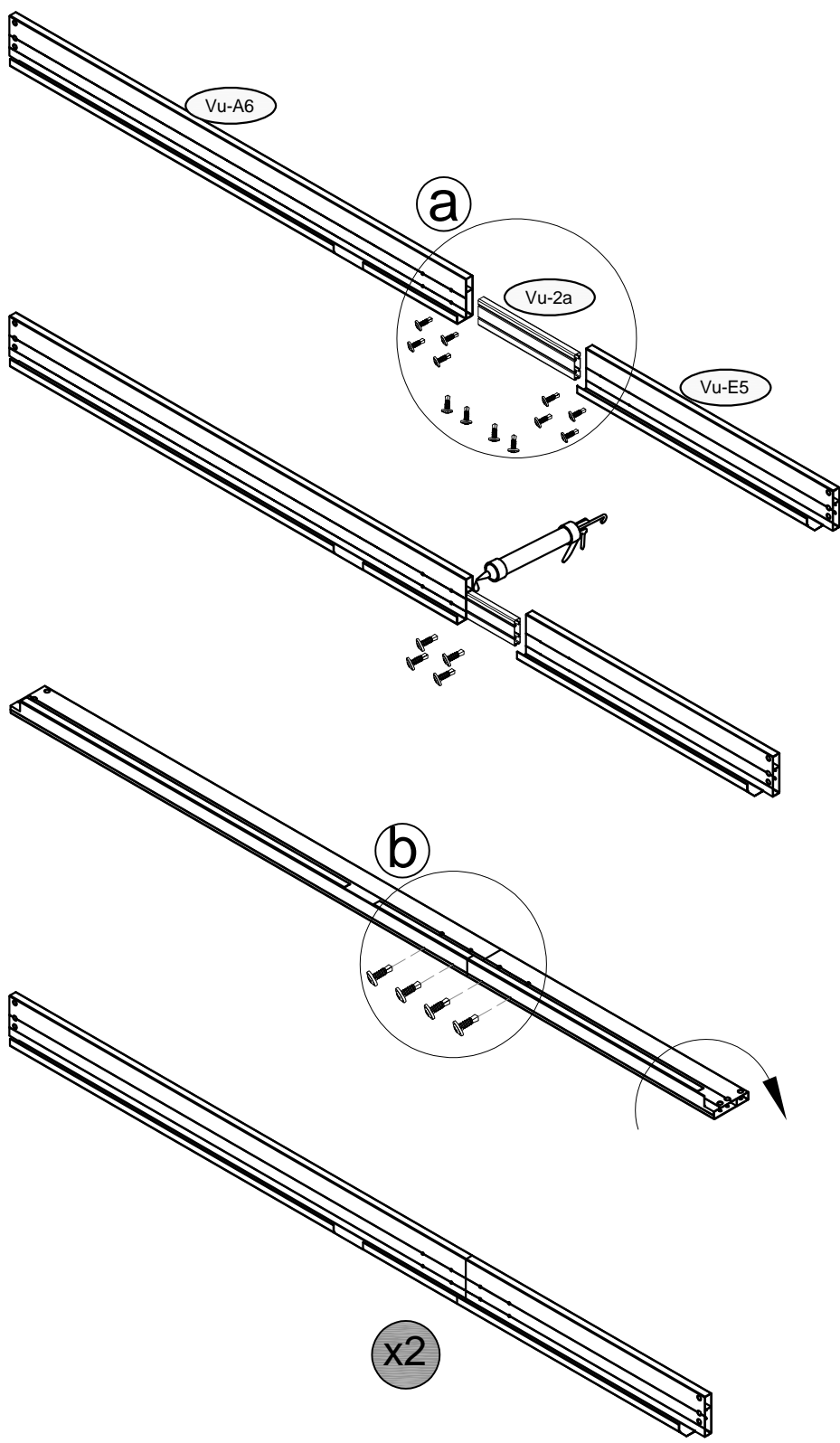



3	 Vu-E5 x2	 Vu-A6 x2	 Vu-2a x2	 Vu-K34 x24
----------	---	---	---	---

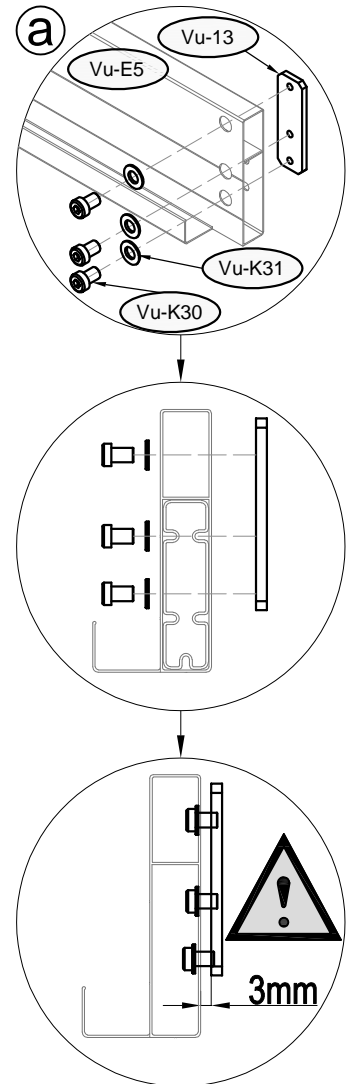
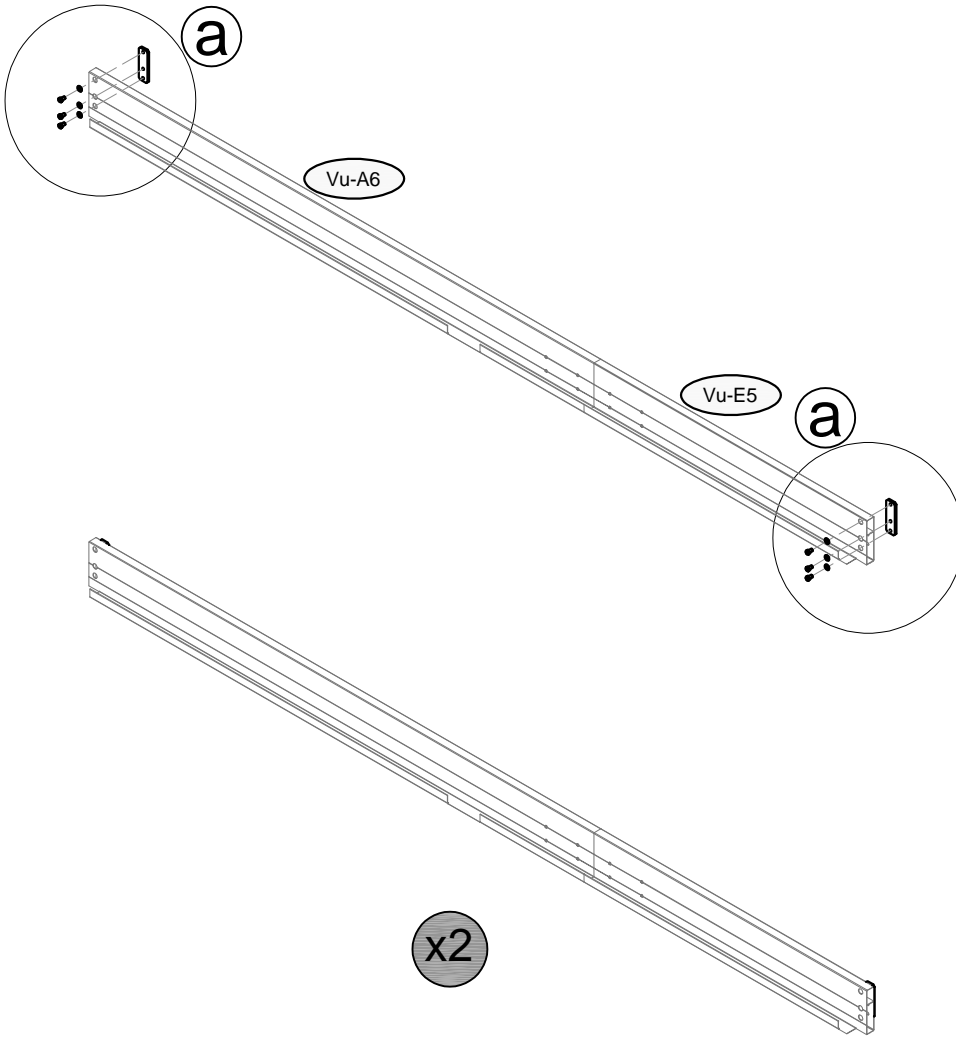



4	 Vu-13 x4	 Vu-K30 x12	 Vu-K31 x12
----------	---	---	---



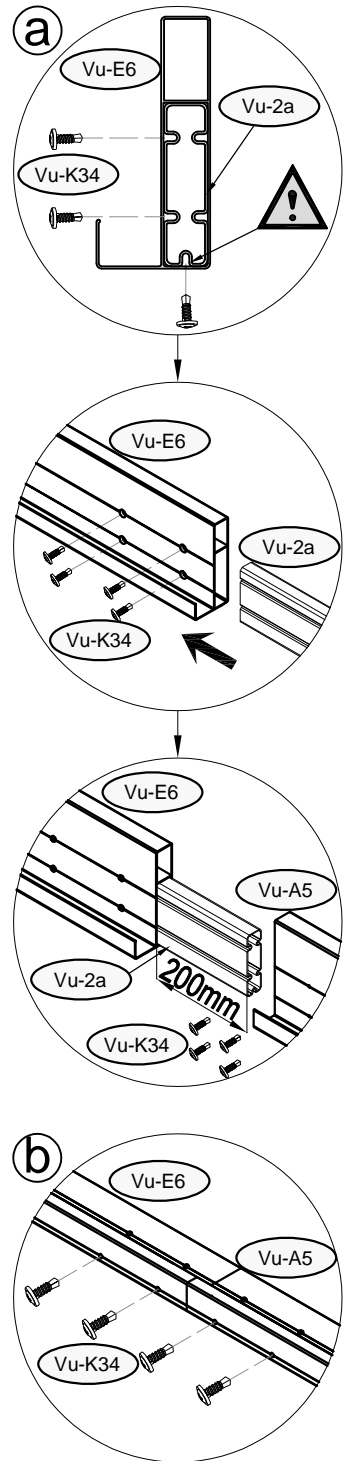
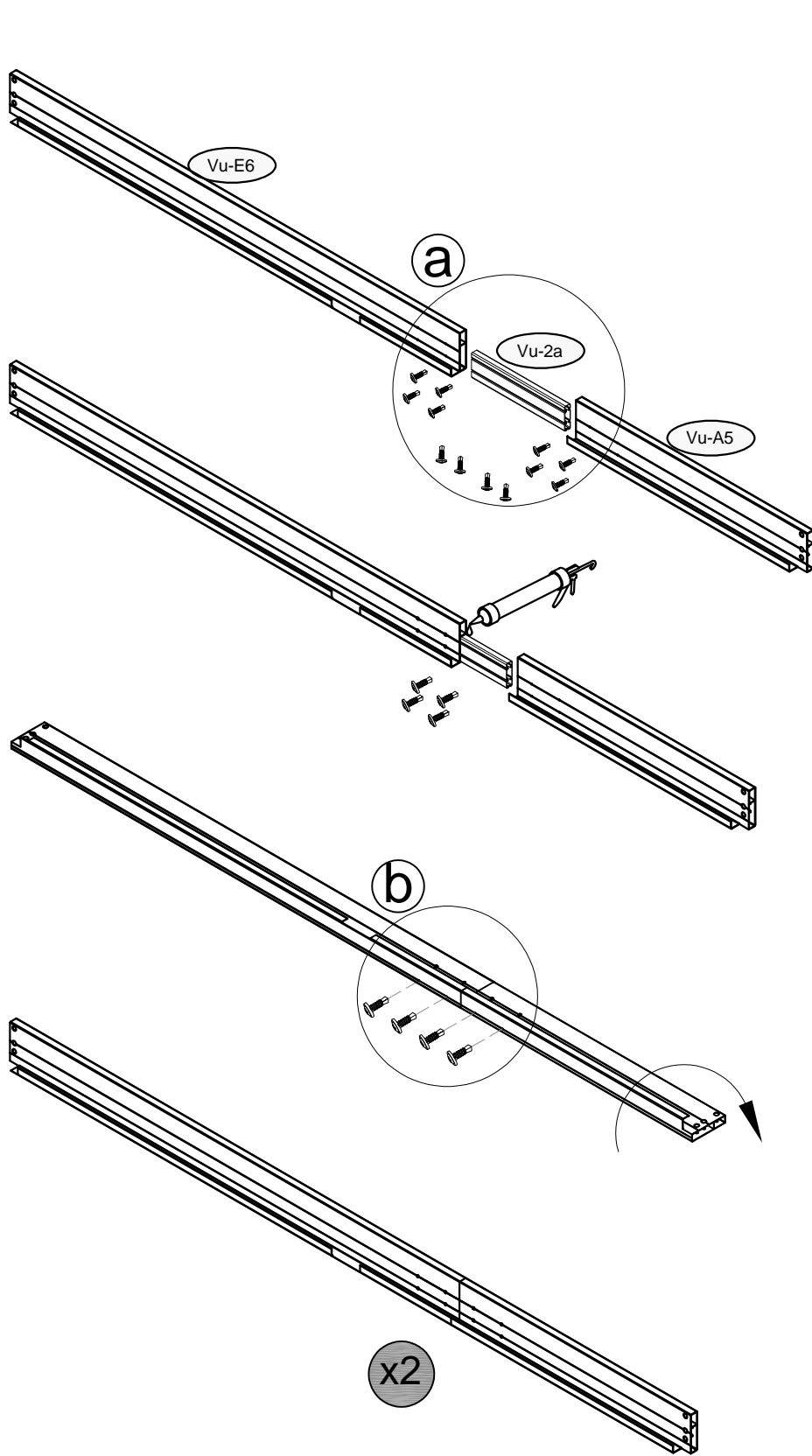



5	 Vu-A5 x2	 Vu-E6 x2	 Vu-2a x2	 Vu-K34 x24	
---	---	---	---	---	--

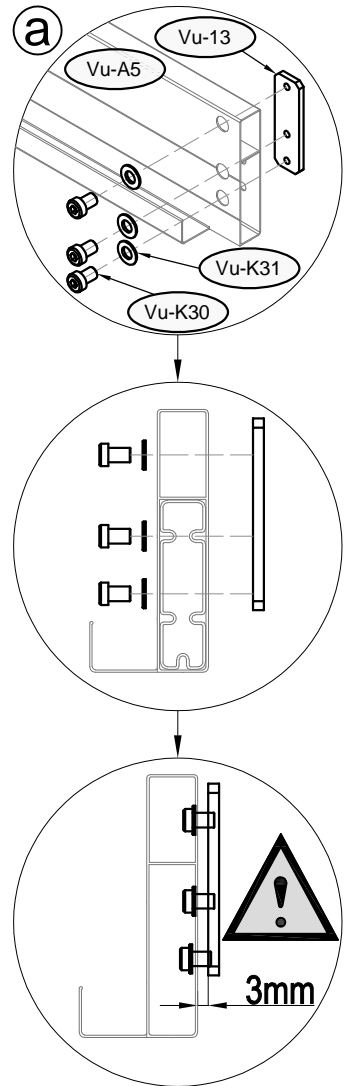
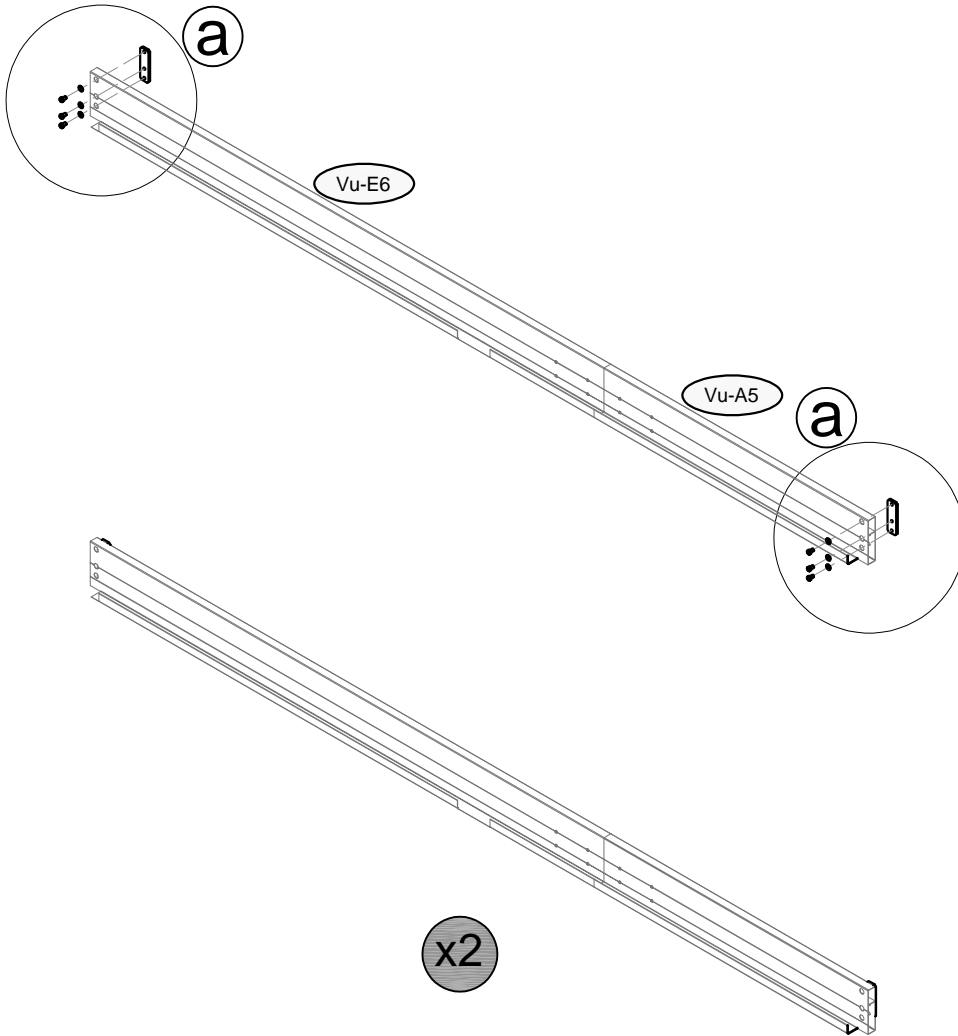

6	 Vu-13 x4	 Vu-K30 x12	 Vu-K31 x12
----------	---	---	---





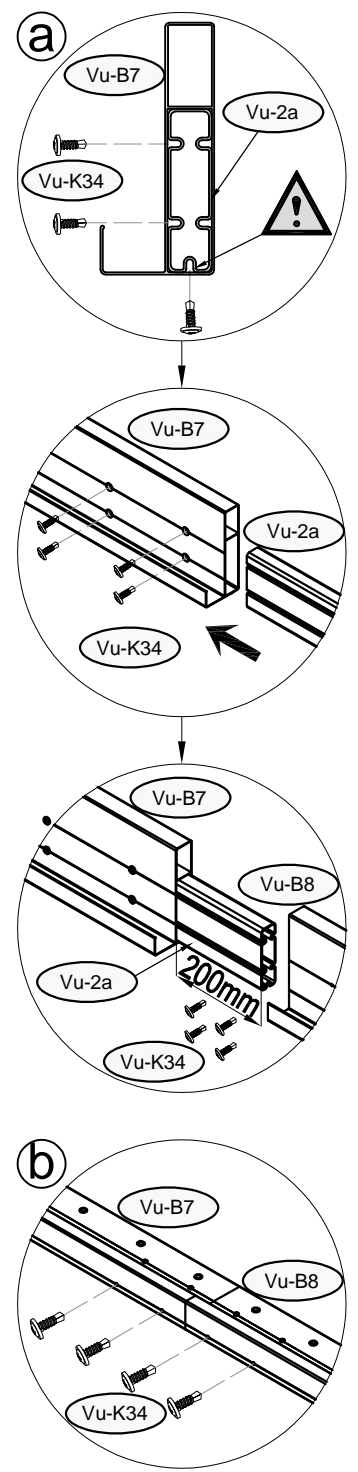
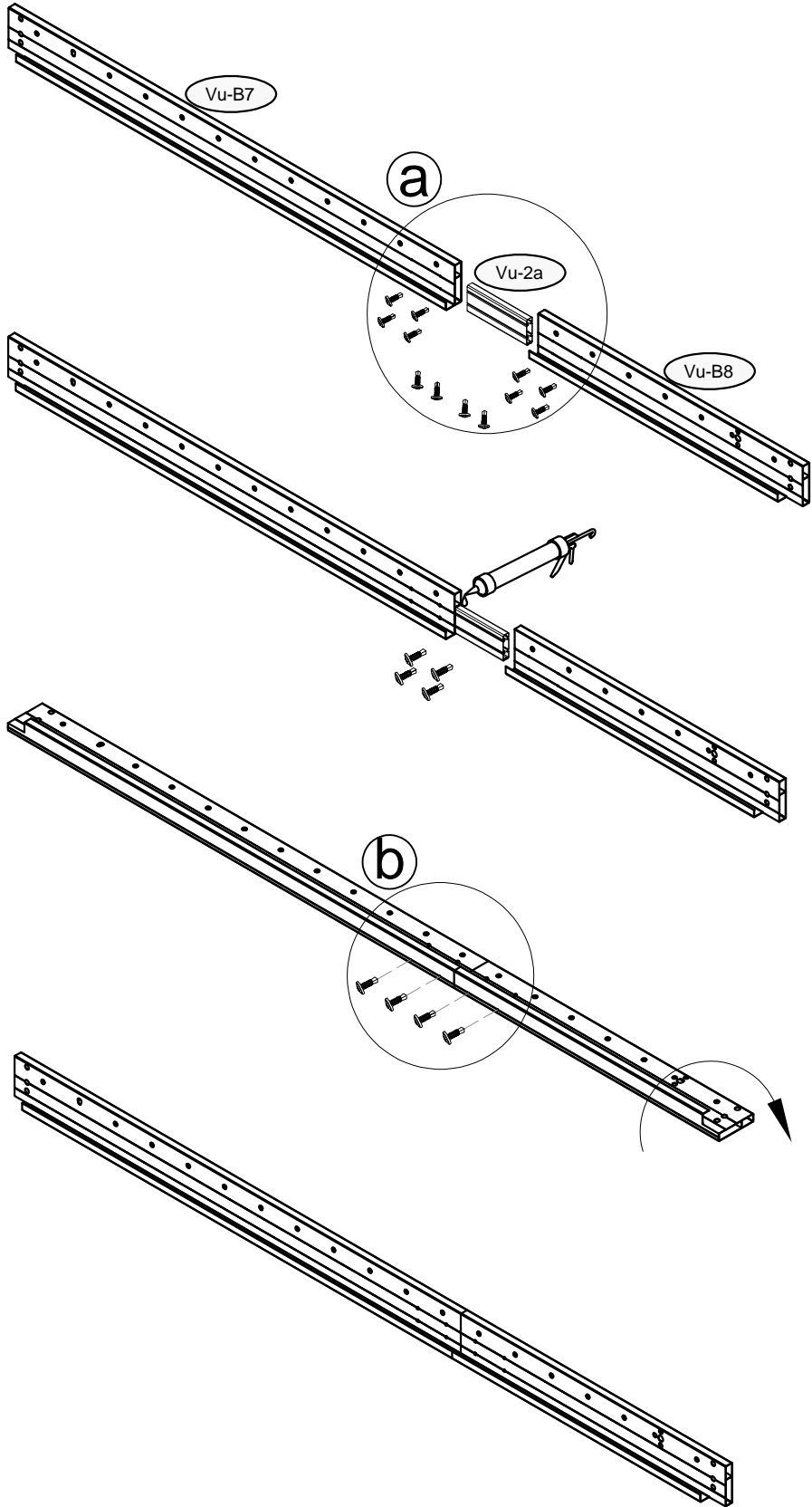

7	 Vu-B7 x1	 Vu-B8 x1	 Vu-2a x1	 Vu-K34 x12
----------	---	---	---	---

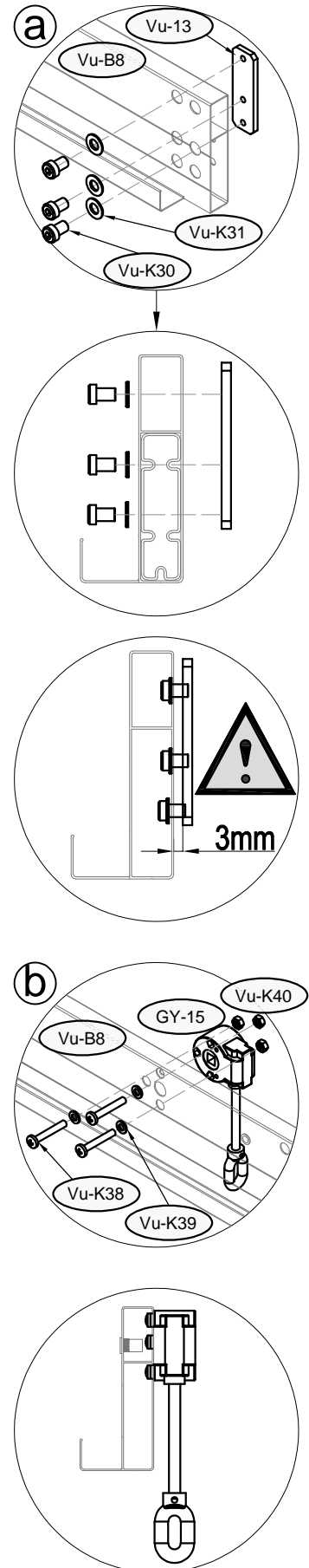
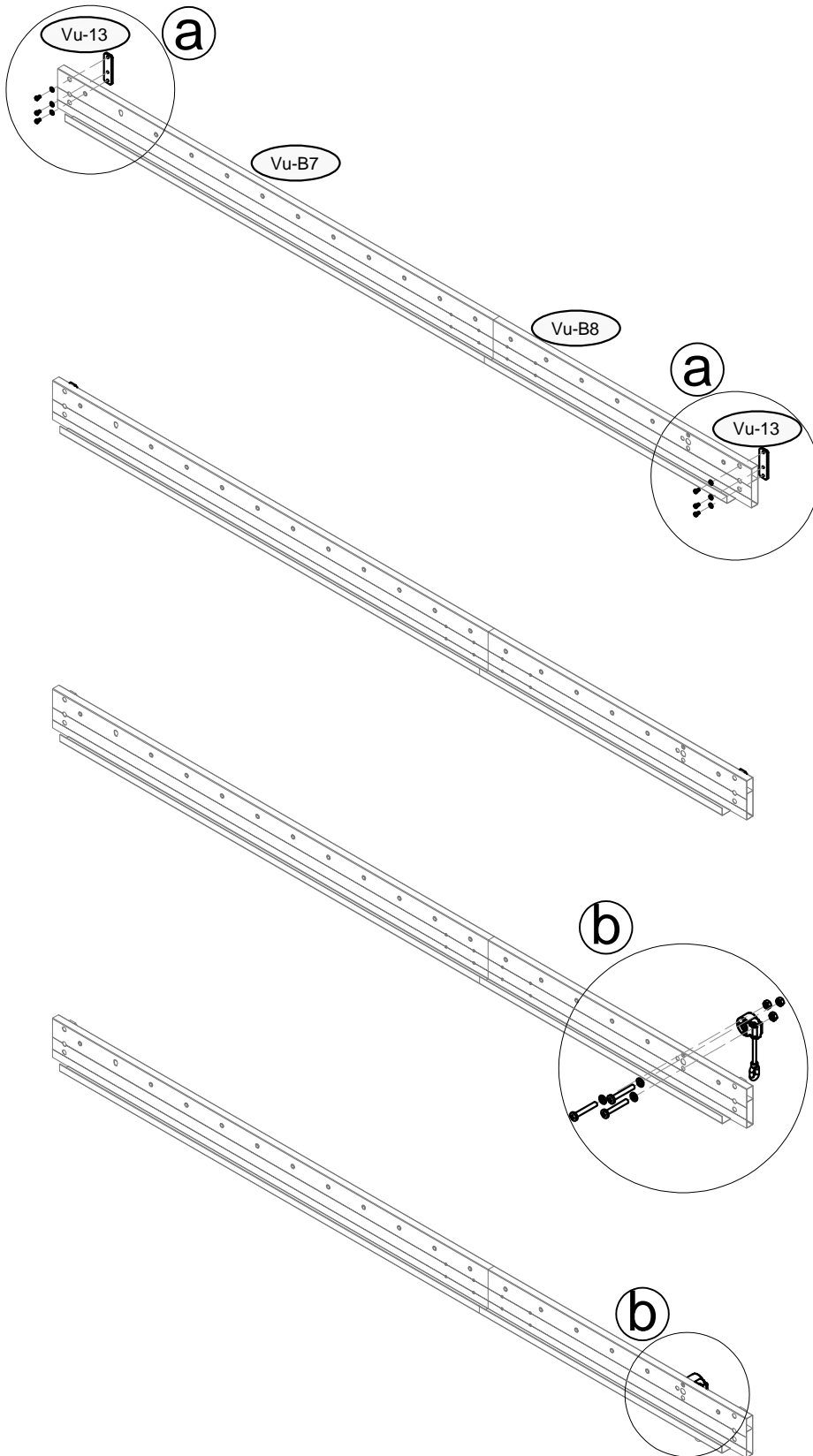

8	 Vu-13 x2	 GY-15 x1	 Vu-K30 x6	 Vu-K31 x6	 Vu-K38 x3	 Vu-K39 x3	 Vu-K40 x3
---	---	---	--	--	--	--	--





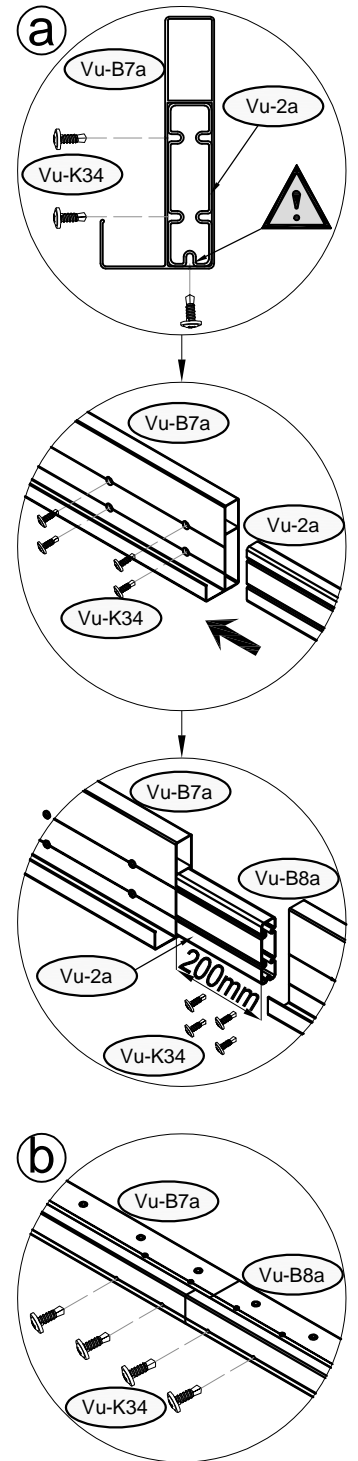
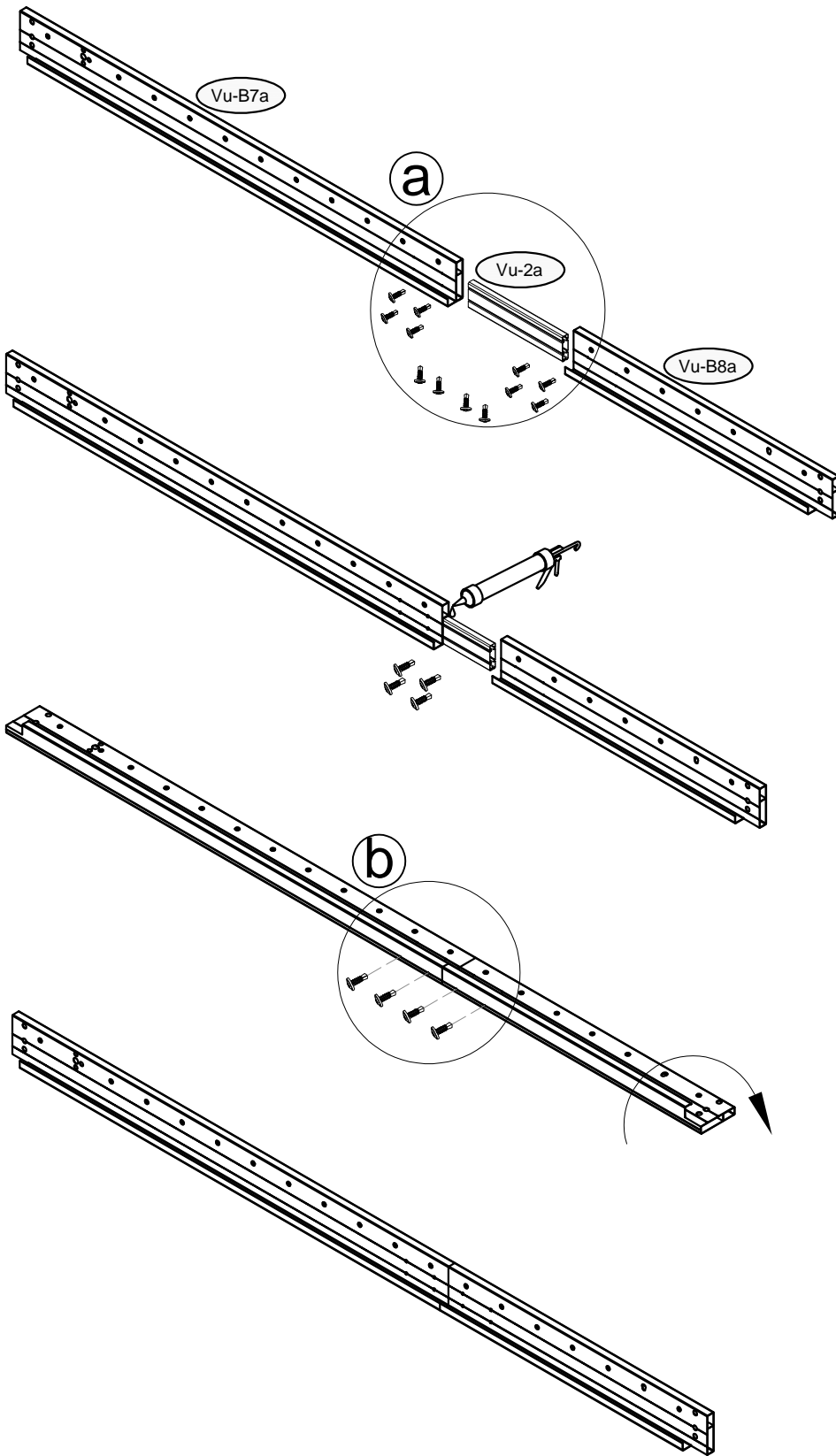

9	 Vu-B7a x1	 Vu-B8a x1	 Vu-2a x1	 Vu-K34 x12	
---	--	--	---	---	--

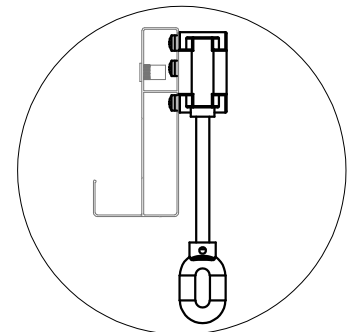
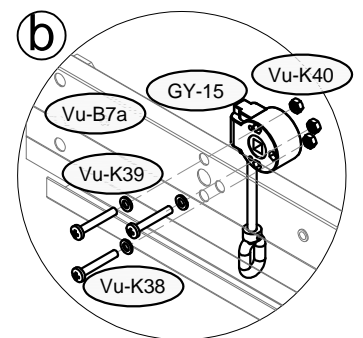
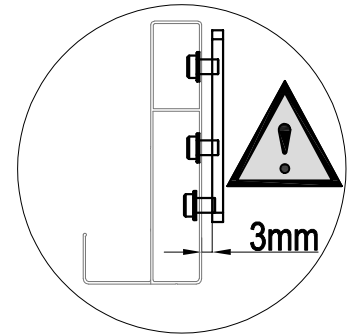
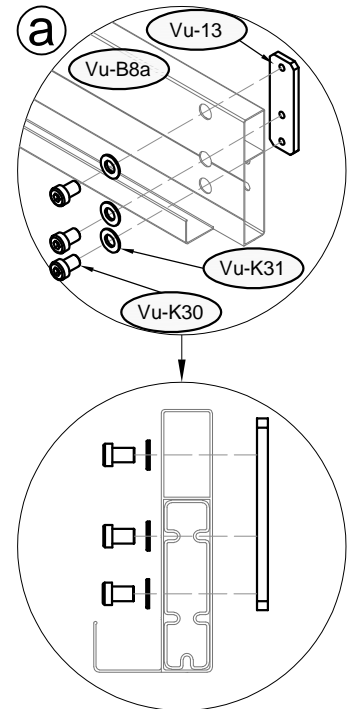
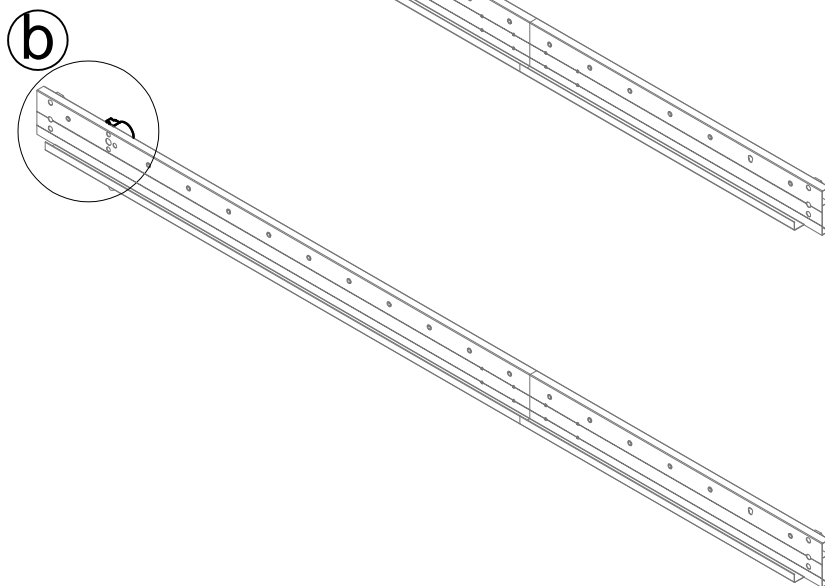
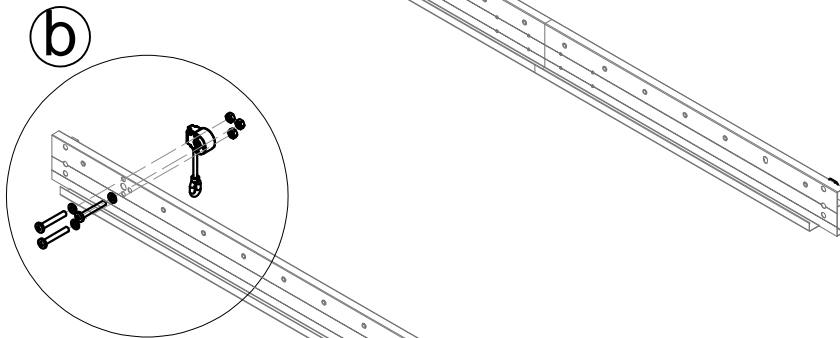
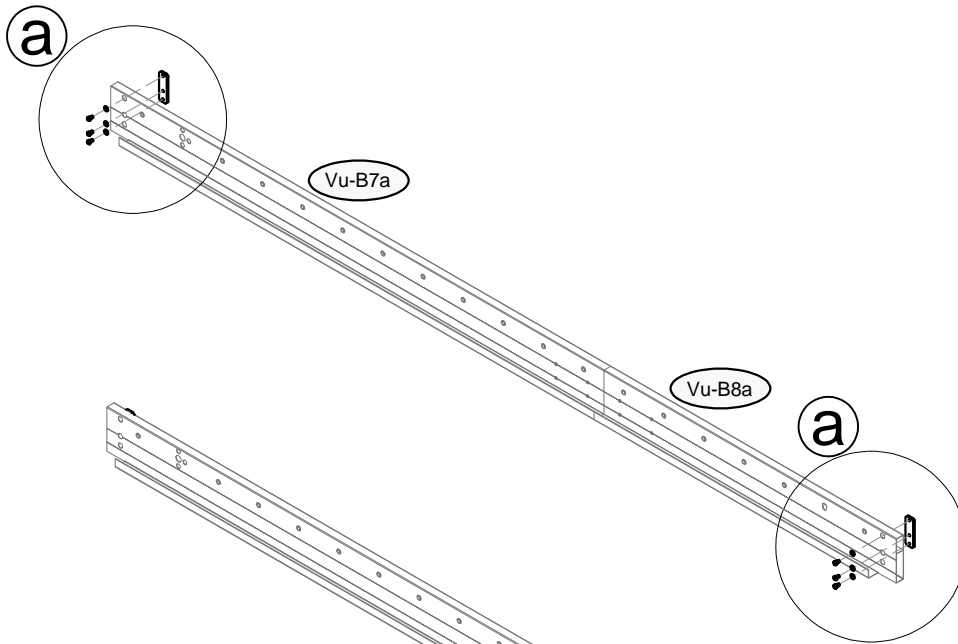





10	 Vu-13 x2	 GY-15 x1	 Vu-K30 x6	 Vu-K31 x6	 Vu-K38 x3	 Vu-K39 x3	 Vu-K40 x3
----	---	---	--	--	---	--	--

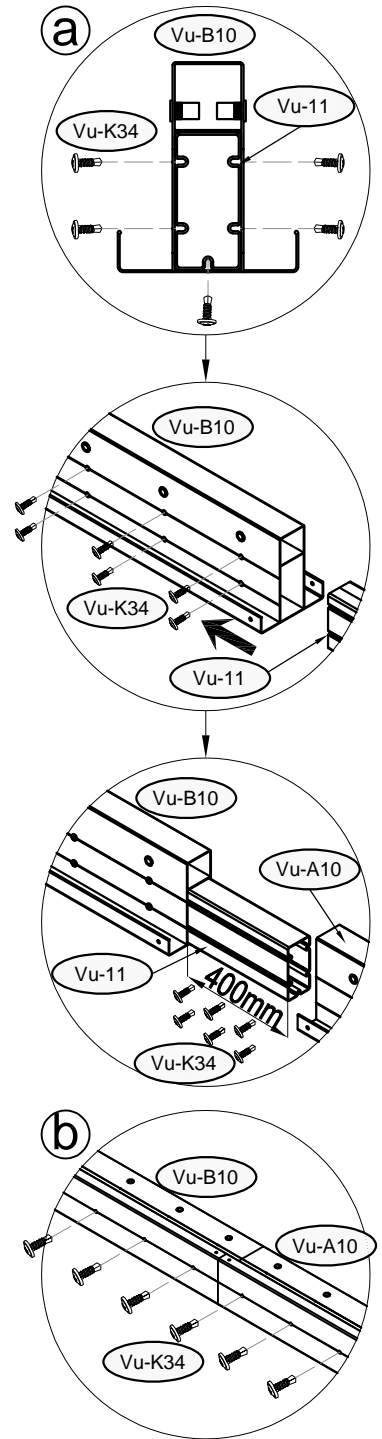
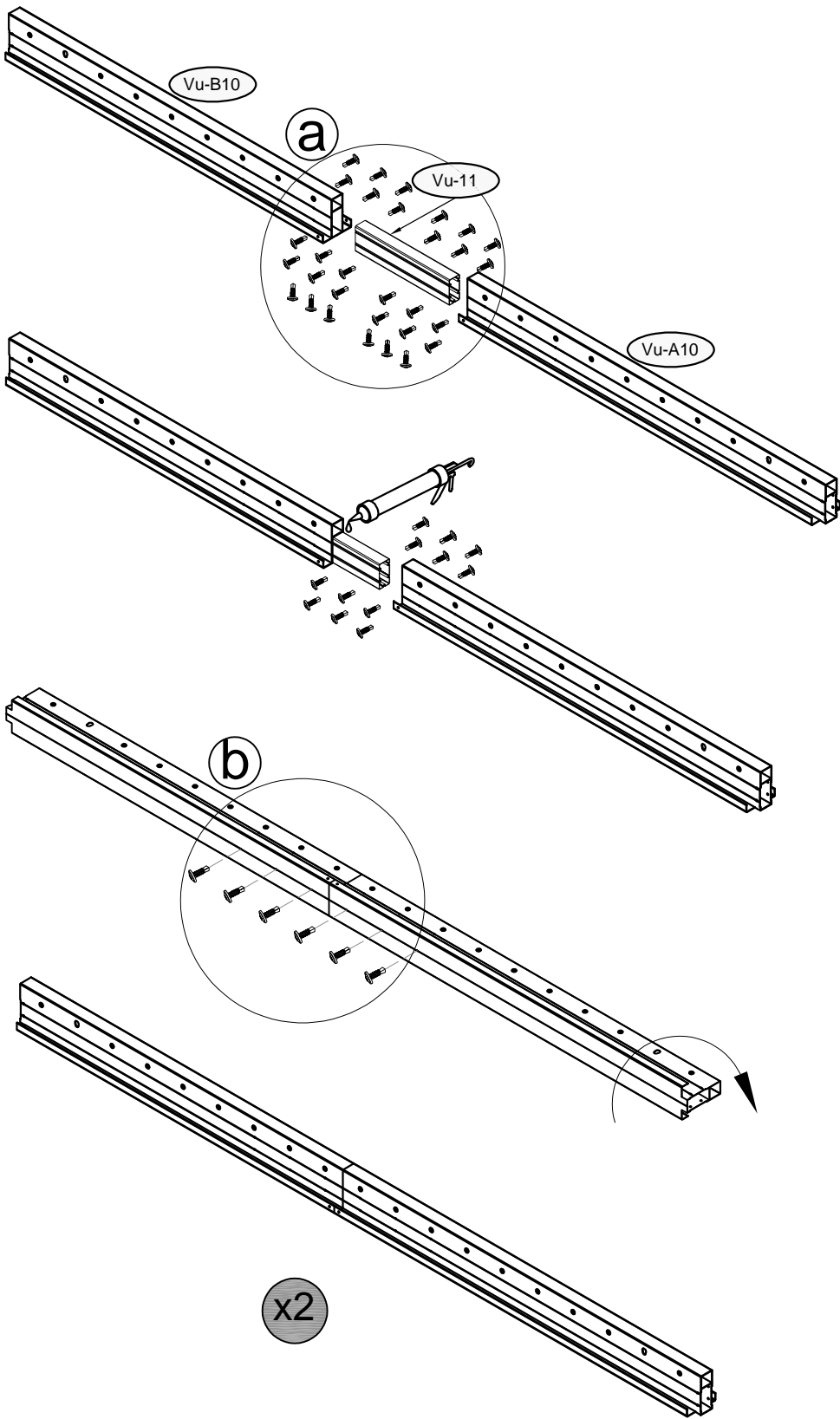





11	 Vu-A10 x2	 Vu-B10 x2	 Vu-11 x2	 Vu-K34 x60	
----	--	--	---	---	--

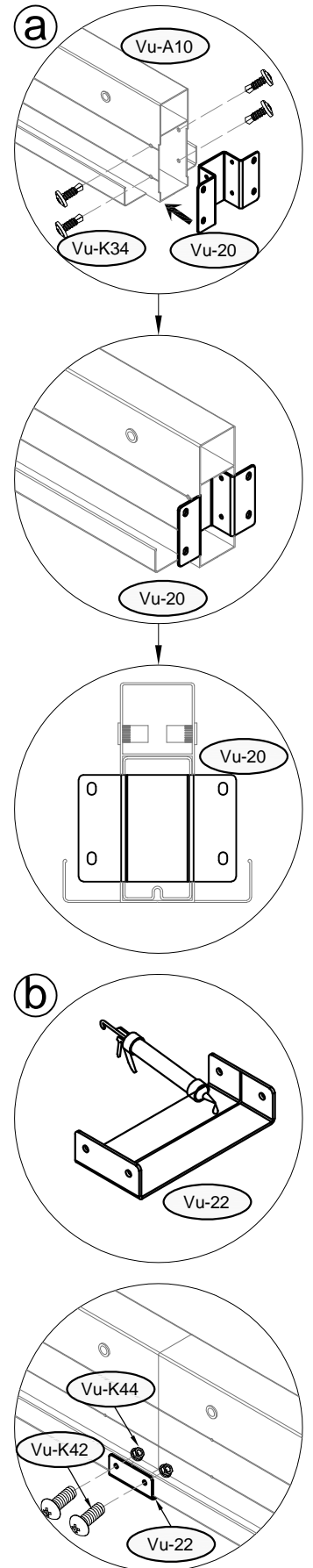
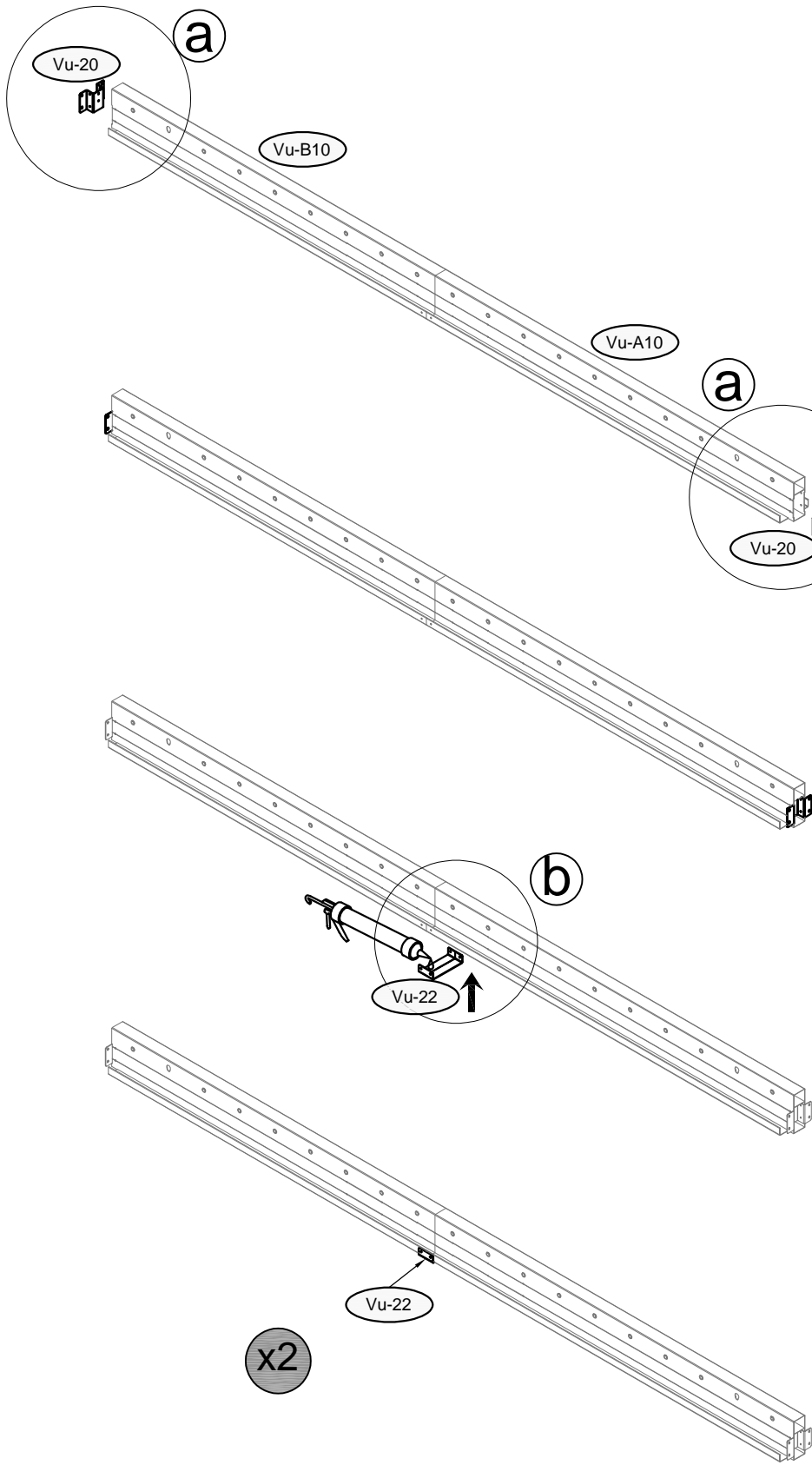





12	 Vu-20 x4	 GY-22 x2	 Vu-K34 x16	 Vu-K42 x8	 Vu-K44 x8
----	---	---	---	--	--

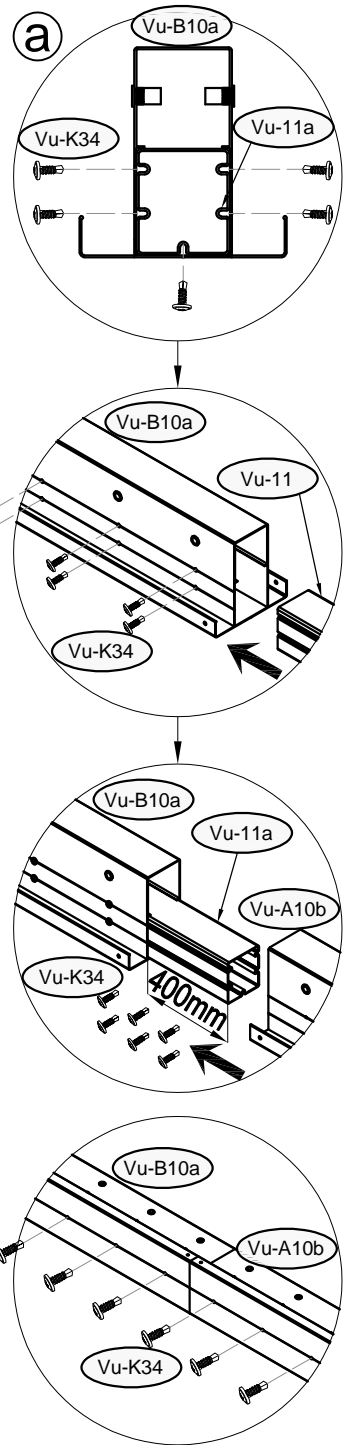
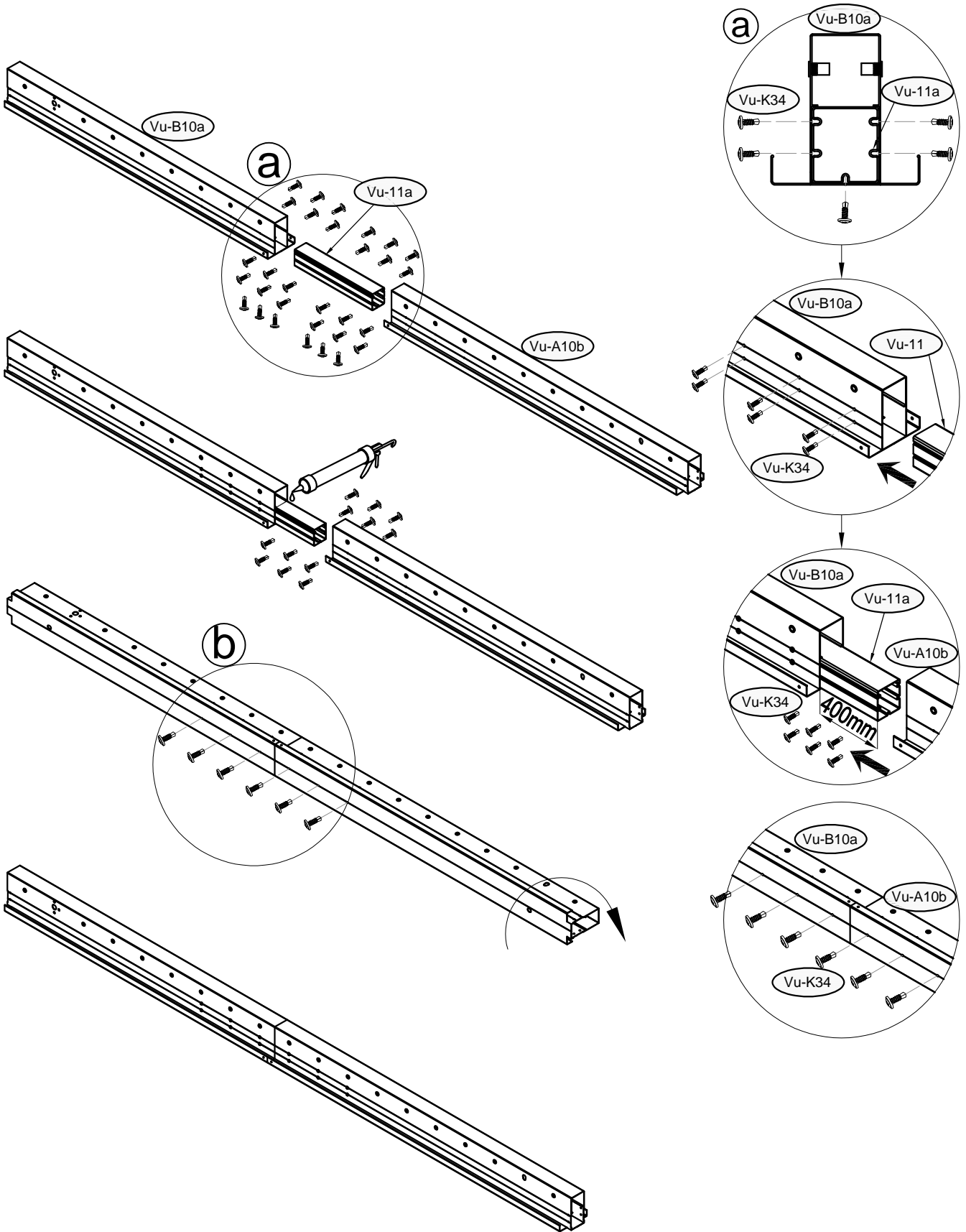

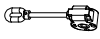
<p>13</p>	 <p>Vu-A10b x1</p>	 <p>Vu-B10a x1</p>	 <p>Vu-11a x1</p>	 <p>Vu-K34 x30</p>	
-----------	---	---	--	---	--



<p>14</p>	 <p>GY-15a x2</p>	 <p>Vu-K38 x6</p>	 <p>Vu-K39 x6</p>	 <p>Vu-K40 x6</p>	
------------------	--	--	--	--	--

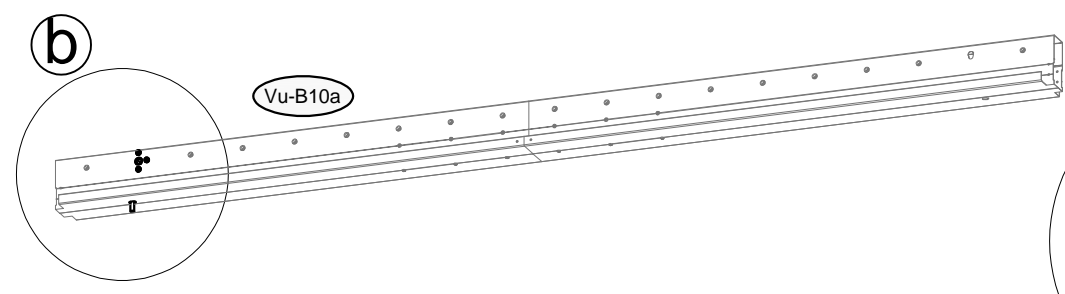
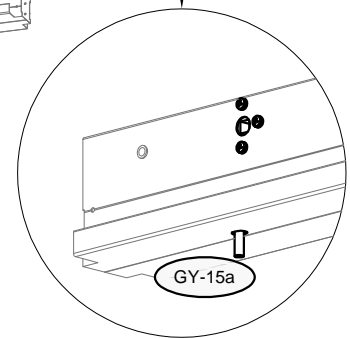
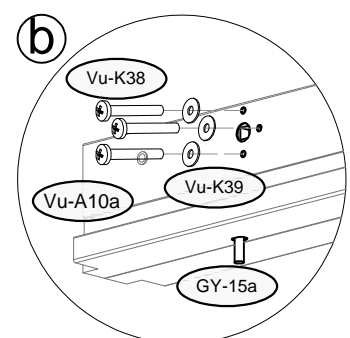
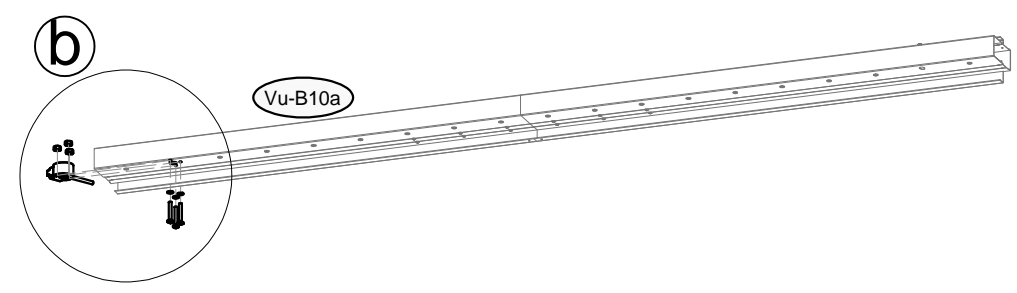
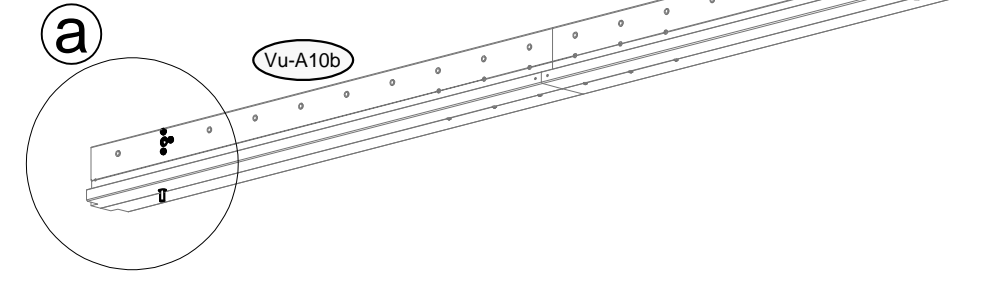
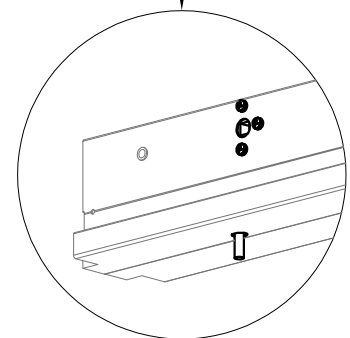
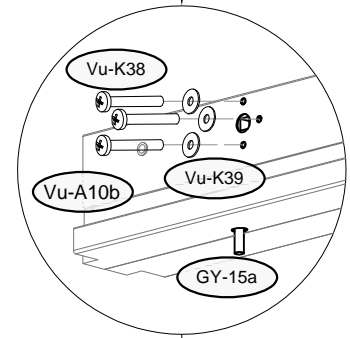
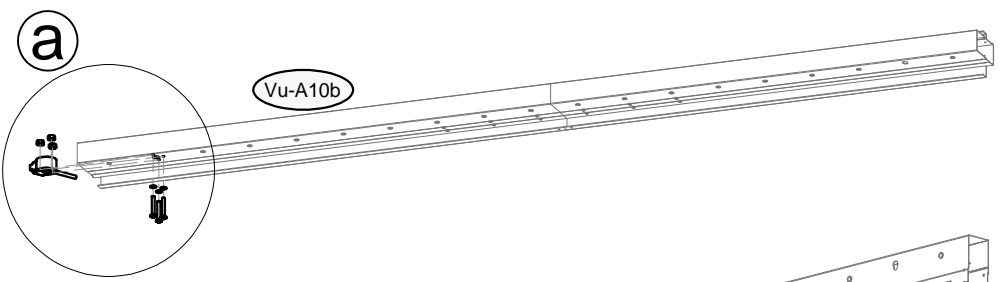
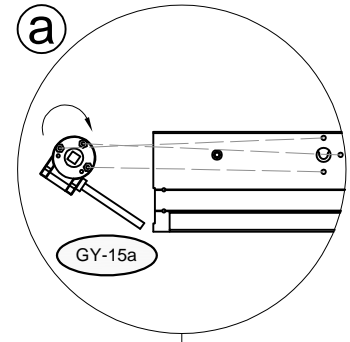
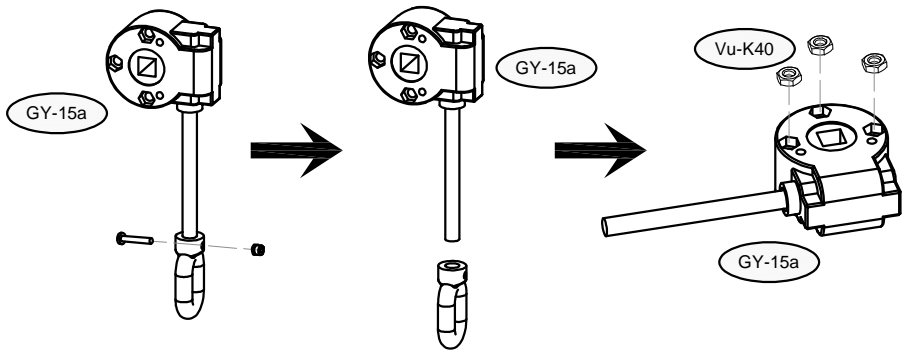



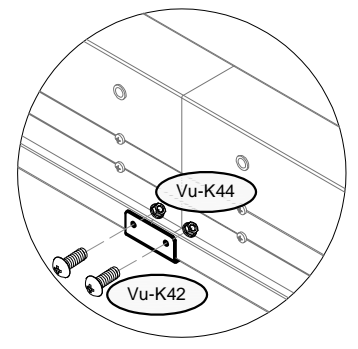
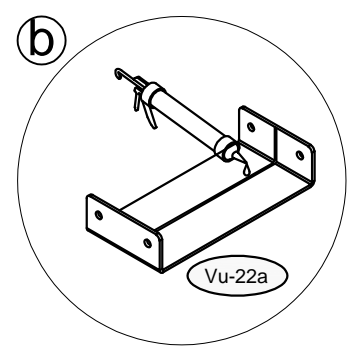
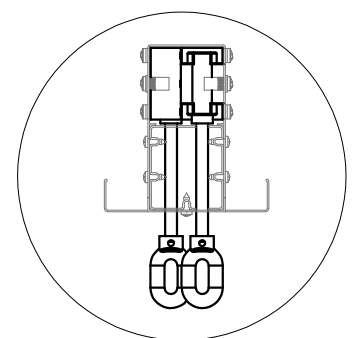
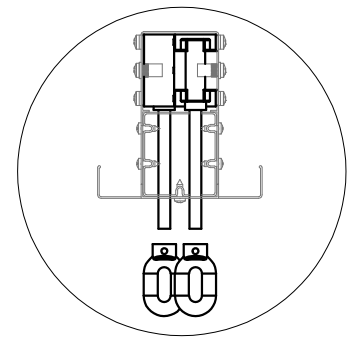
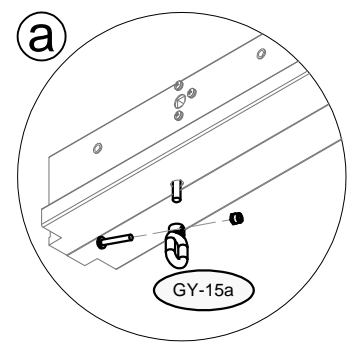
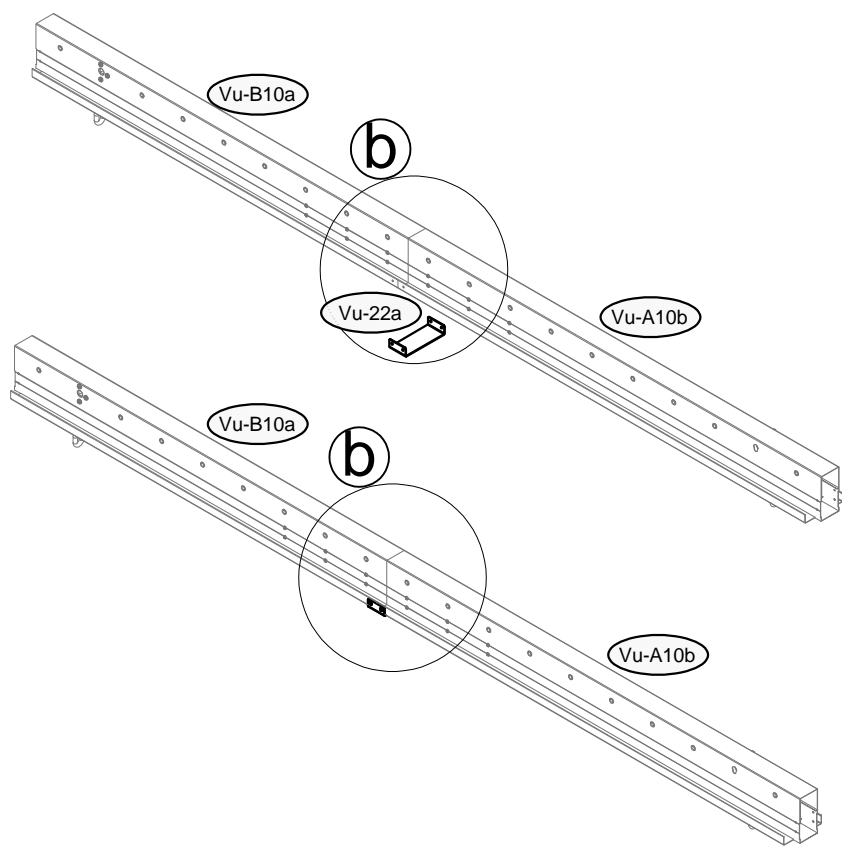
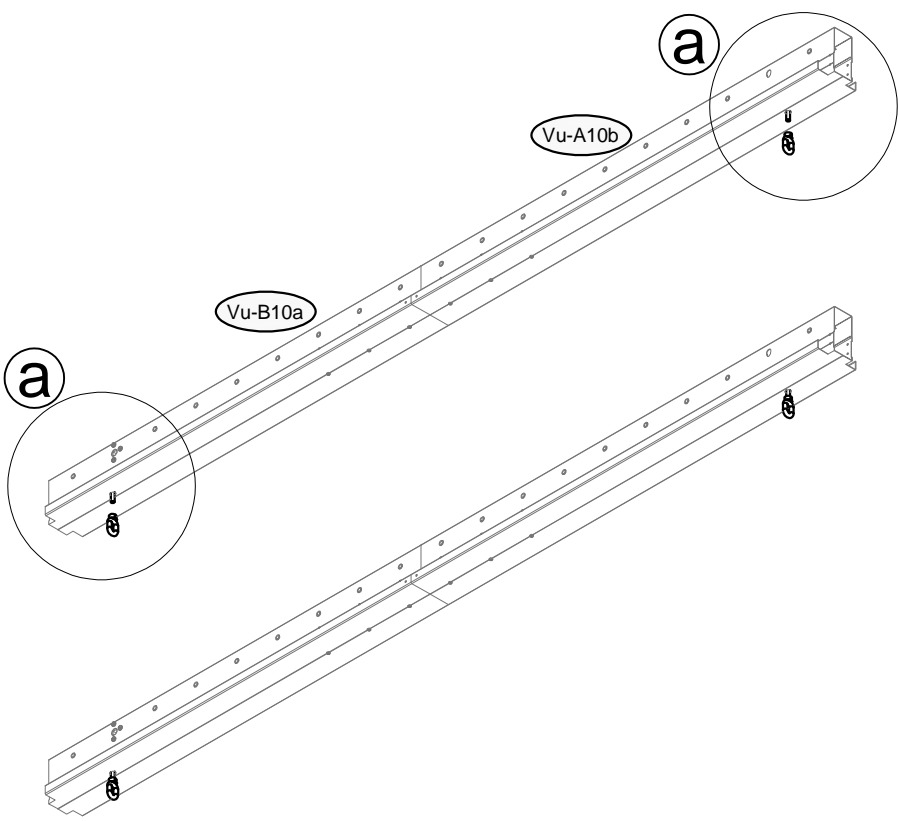

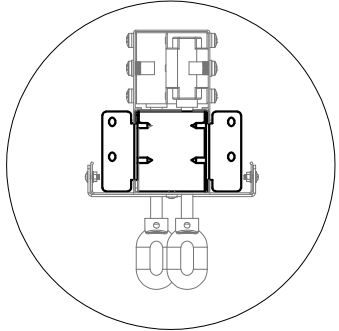
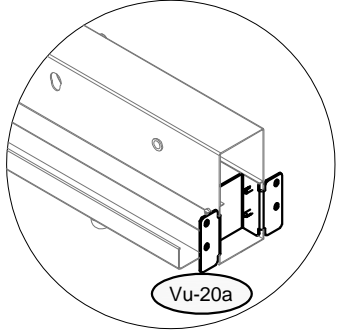
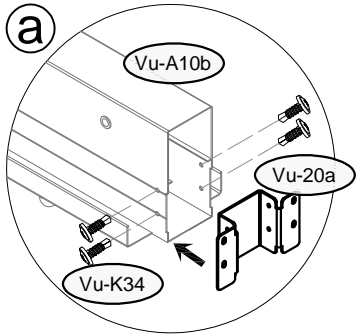
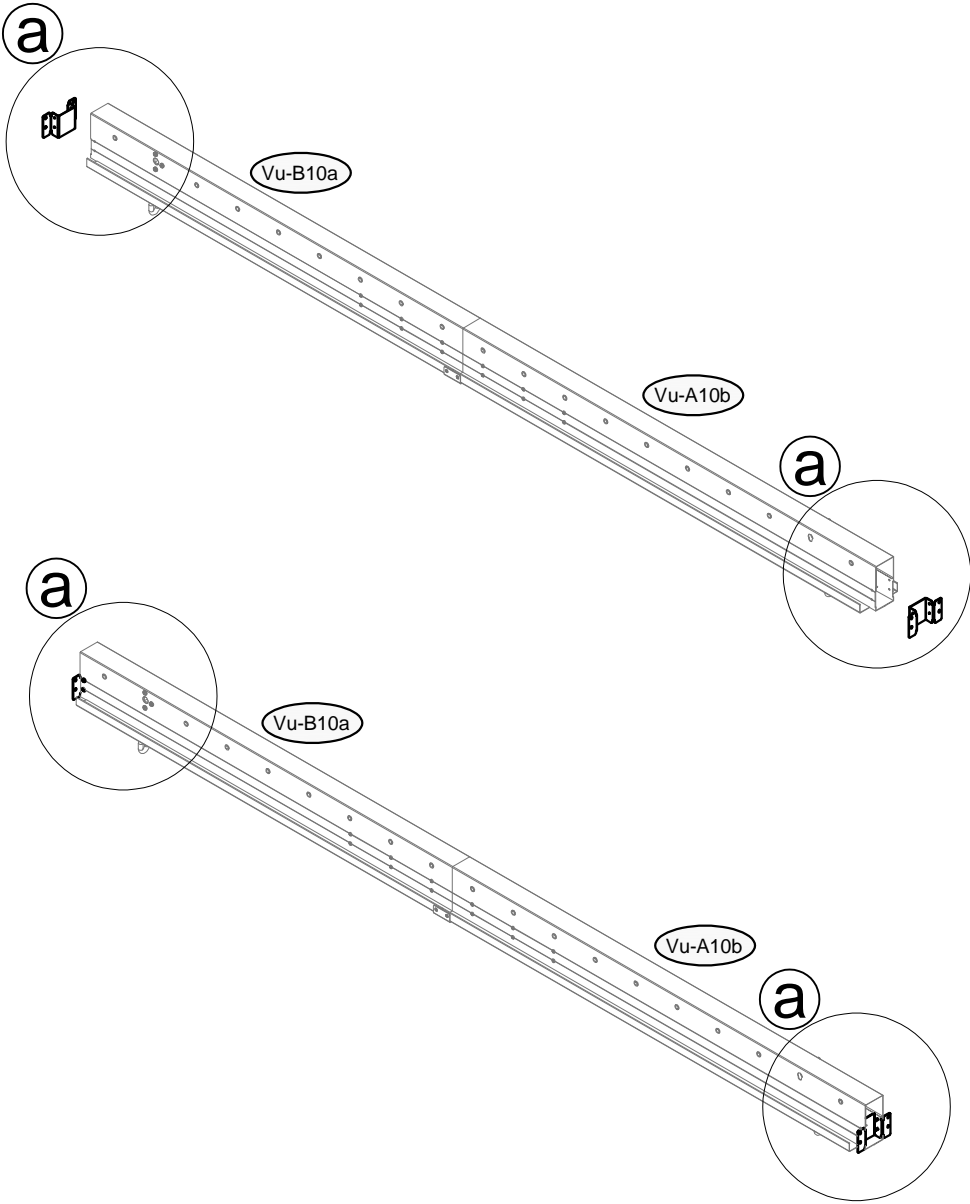

15	 Vu-22a x1	 Vu-K42 x4	 Vu-K44 x4	
----	--	--	--	--







<p>16</p>	 <p>Vu-20a x2</p>	 <p>Vu-K34 x8</p>	
------------------	--	--	--

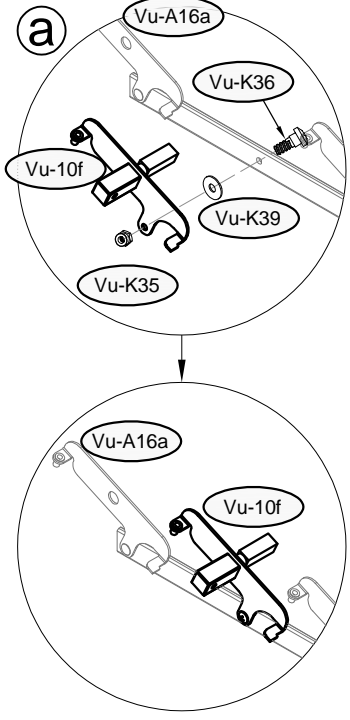
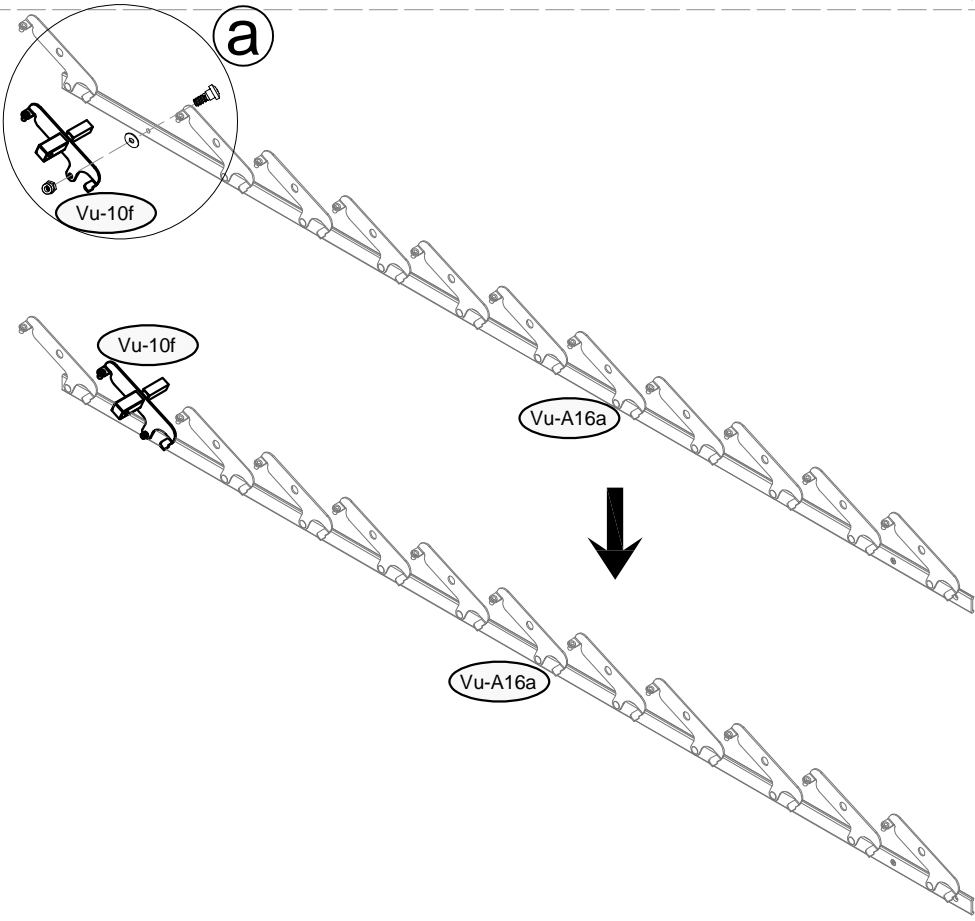
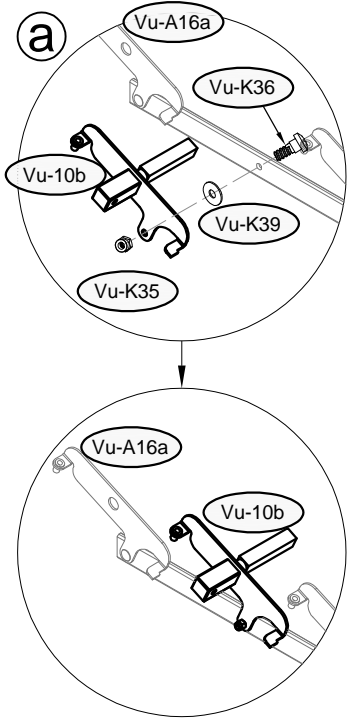
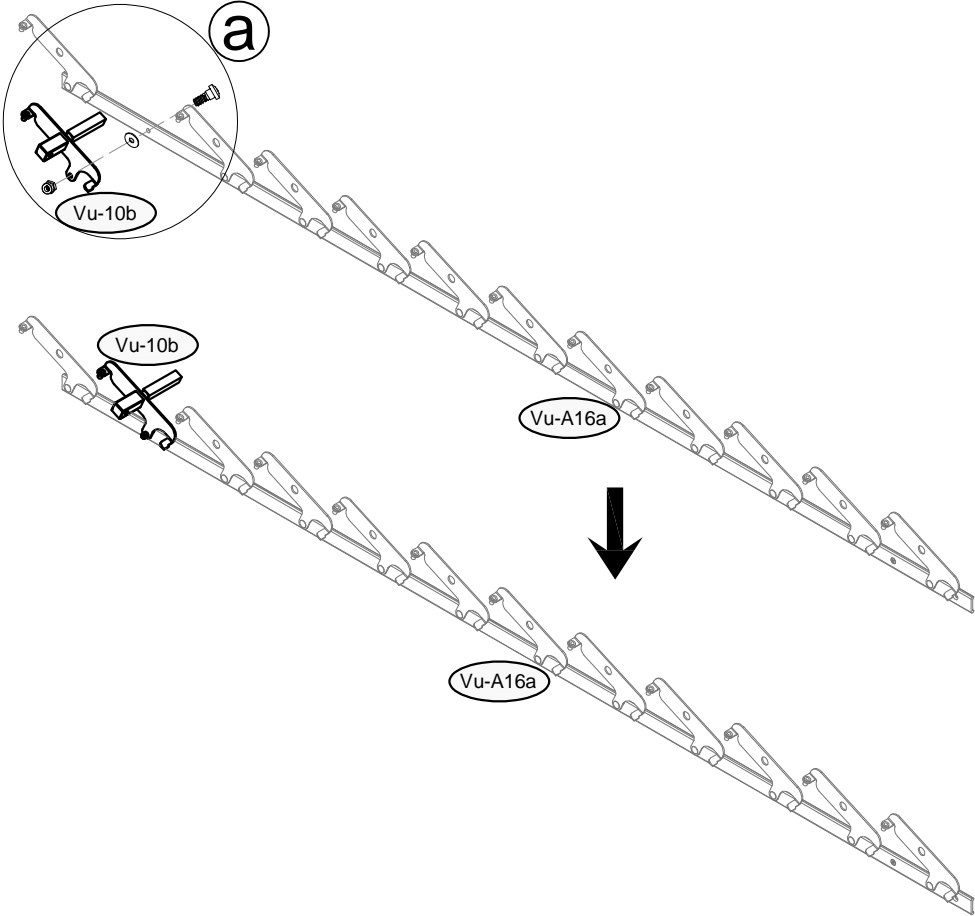

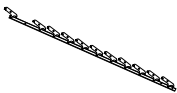
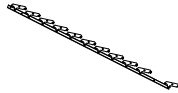

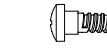

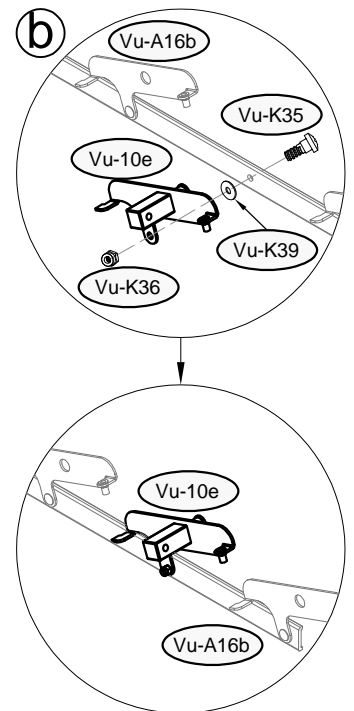
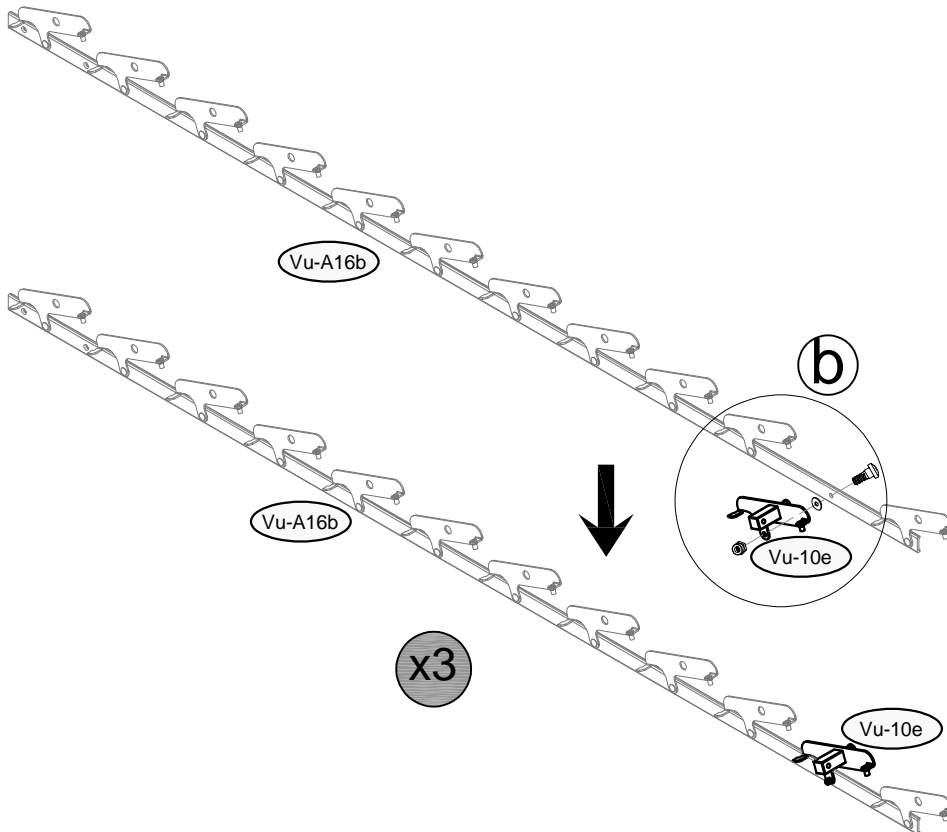
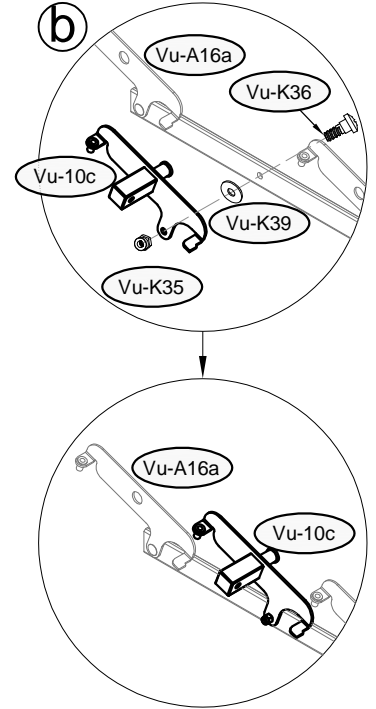
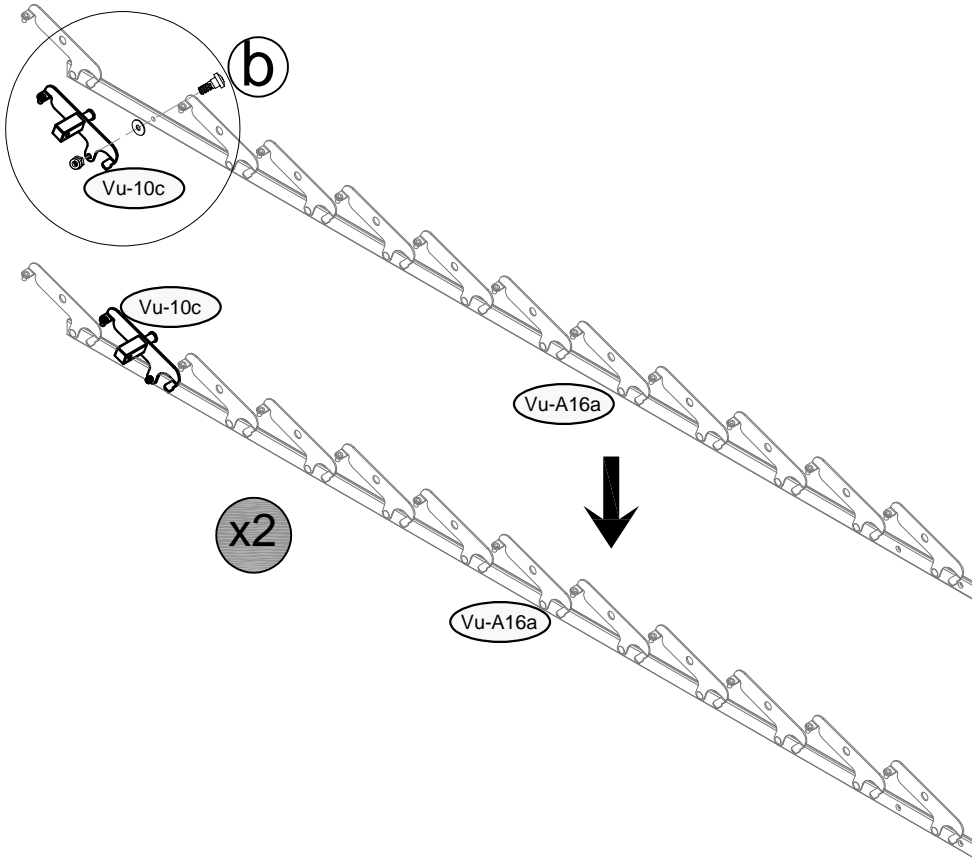

17	 Vu-A16a x2	 Vu-10b x1	 Vu-10f x1	 Vu-K35 x2	 Vu-K36 x2	 Vu-K39 x2	
----	---	--	--	--	--	--	--

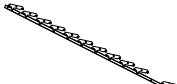
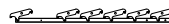





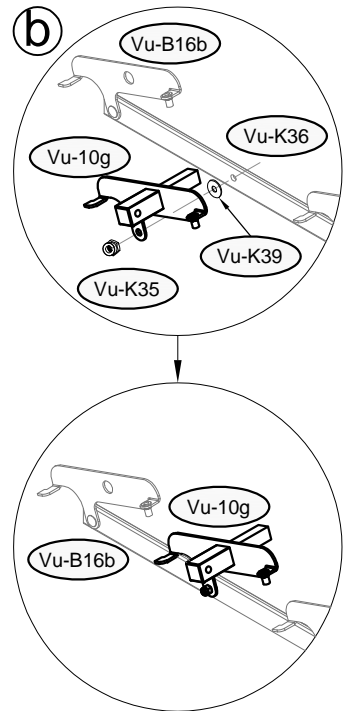
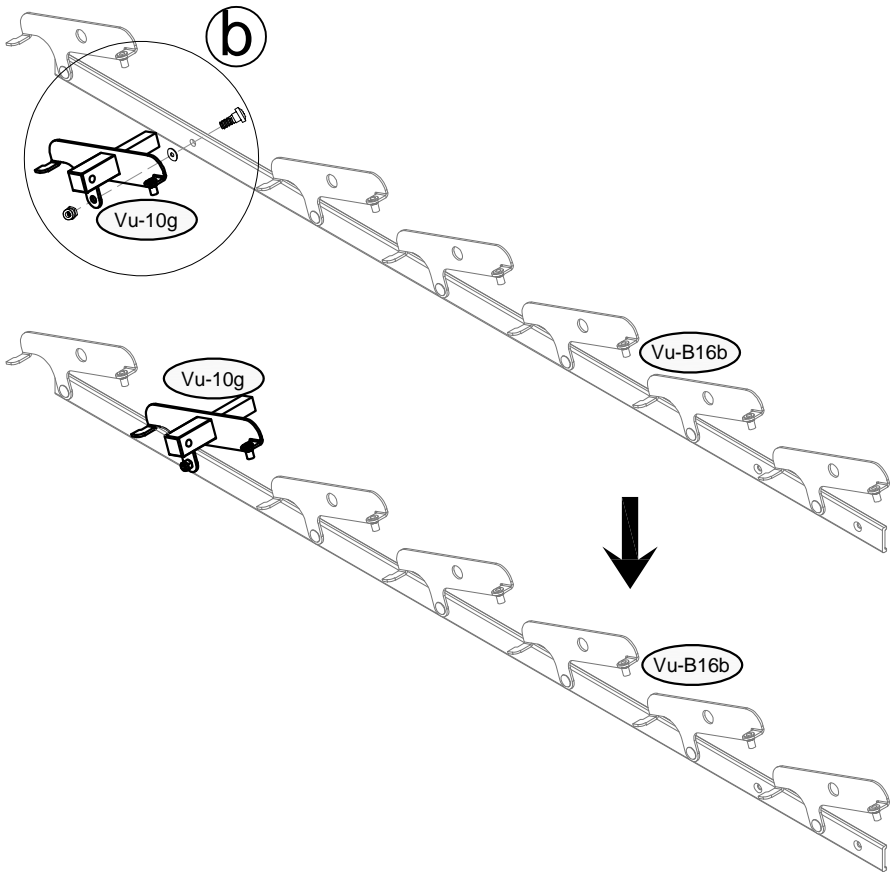
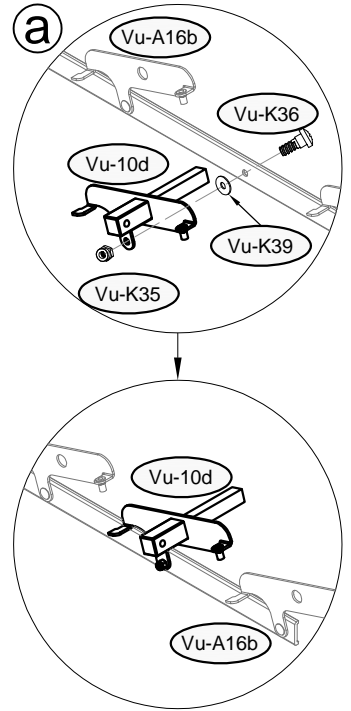
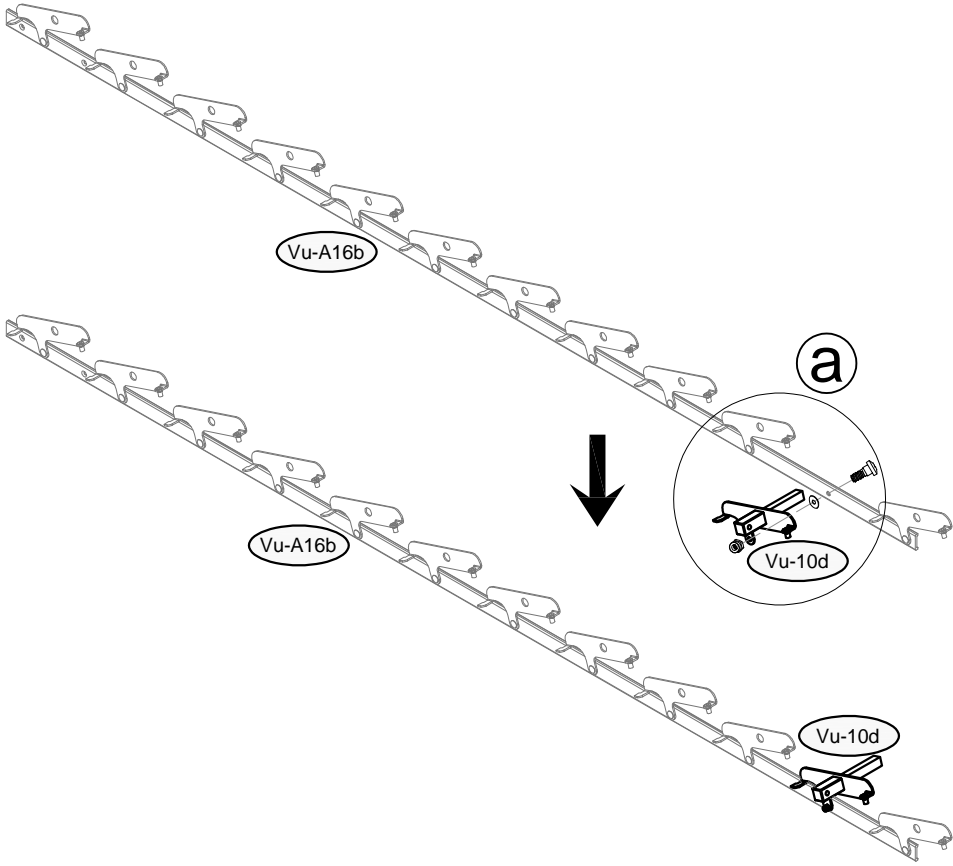

18	 Vu-A16a x2	 Vu-A16b x3	 Vu-10c x2	 Vu-10e x3	 Vu-K35 x5	 Vu-K36 x5	 Vu-K39 x5
----	---	---	--	--	---	--	--

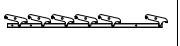
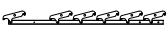

19	 Vu-A16b x1	 Vu-B16b x1	 Vu-10d x1	 Vu-10g x1	 Vu-K35 x2	 Vu-K36 x2	 Vu-K39 x2
----	---	---	--	--	--	--	--



20	 Vu-B16a x4	 Vu-B16b x3	 Vu-10c x4	 Vu-10e x3	 Vu-K35 x7	 Vu-K36 x7	 Vu-K39 x7
----	---	---	--	--	---	--	--

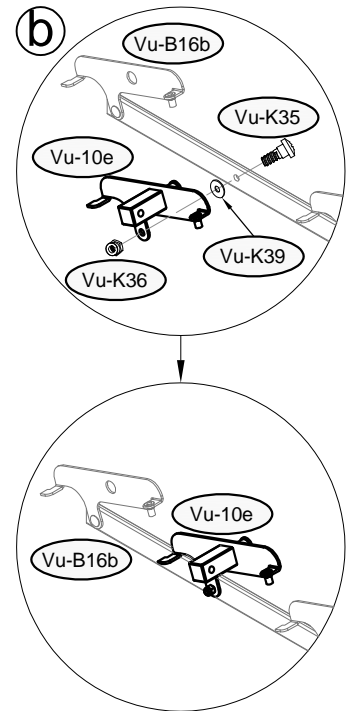
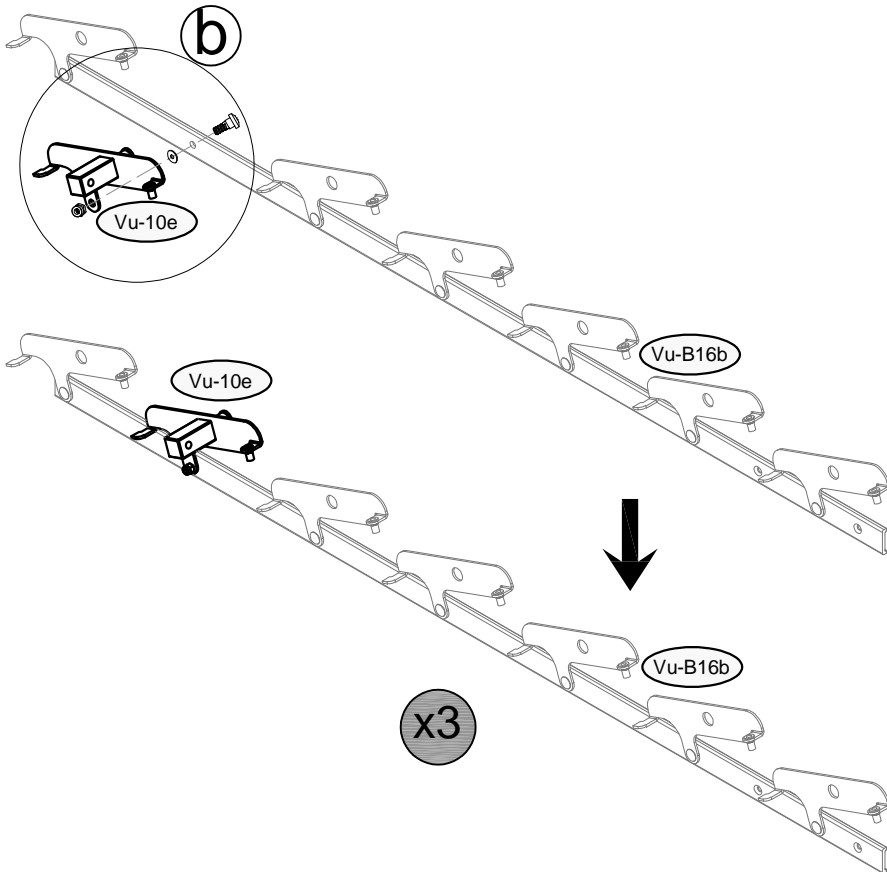
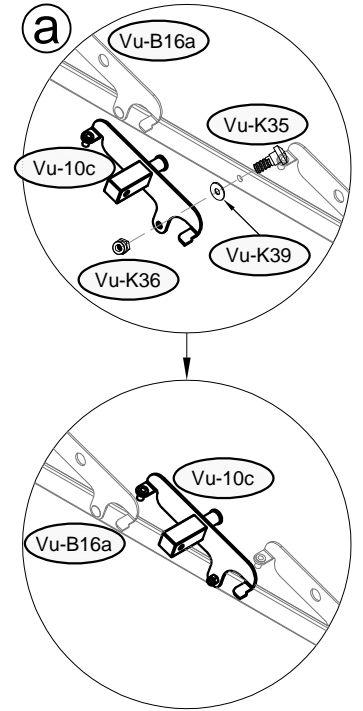
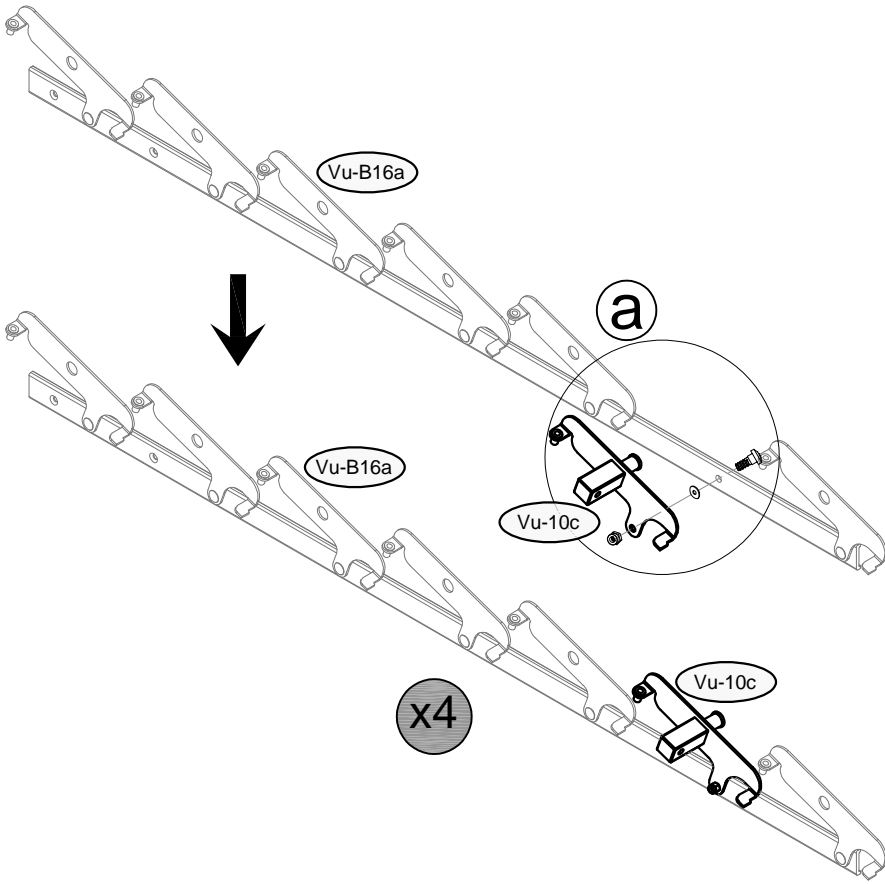

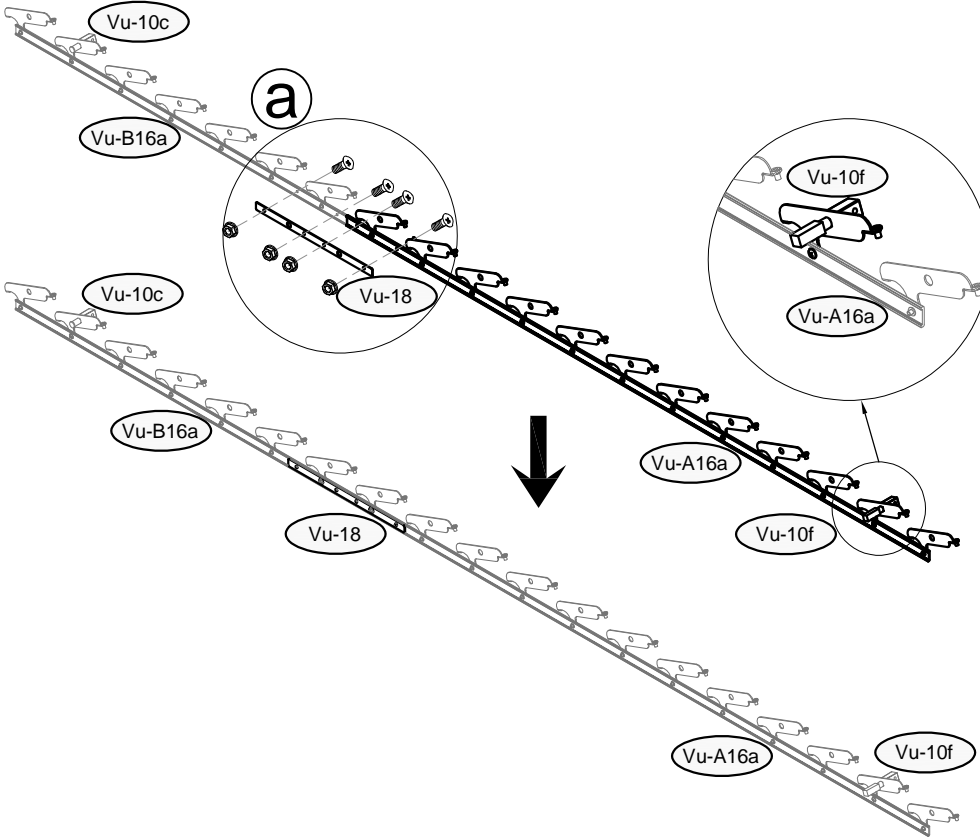
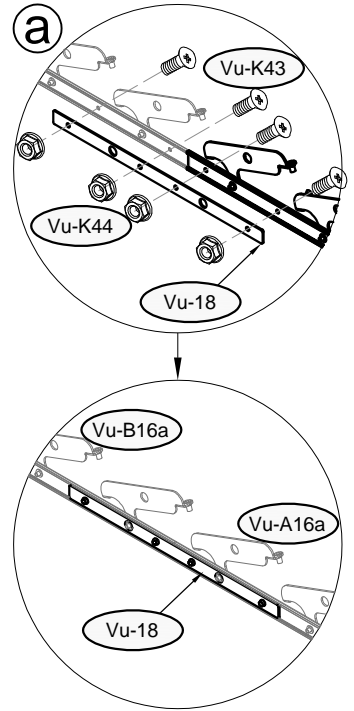
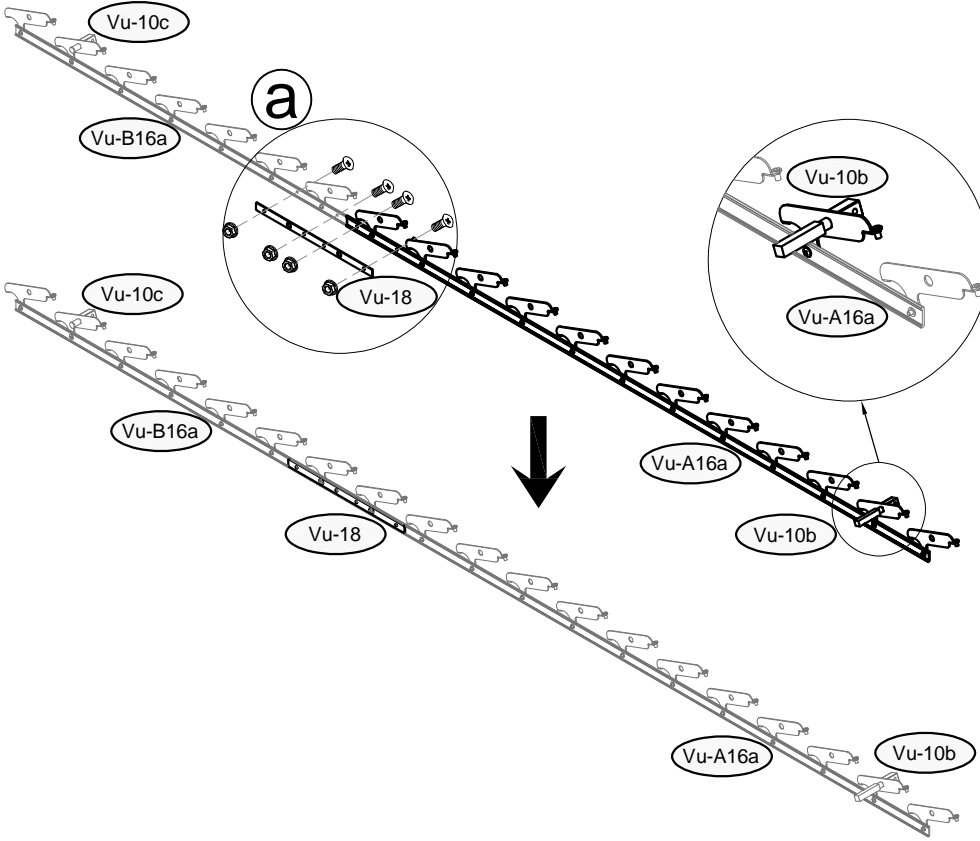

<p>21</p>	 <p>Vu-18 x2</p>	 <p>Vu-K43 x8</p>	 <p>Vu-K44 x8</p>	
------------------	---	--	--	--

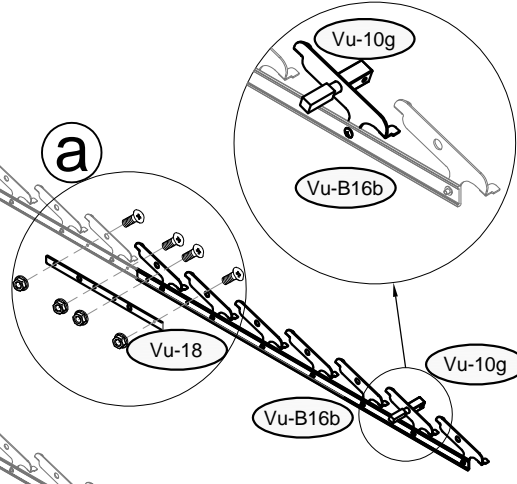
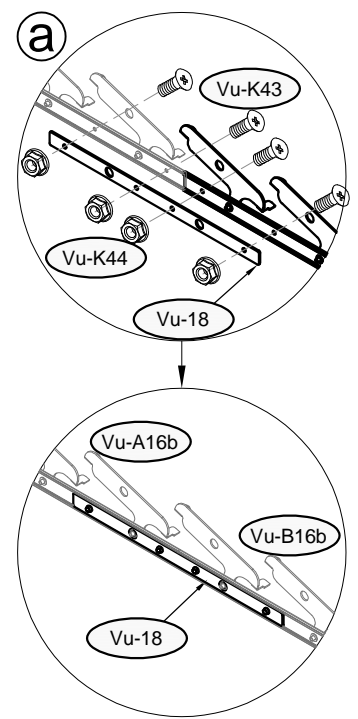
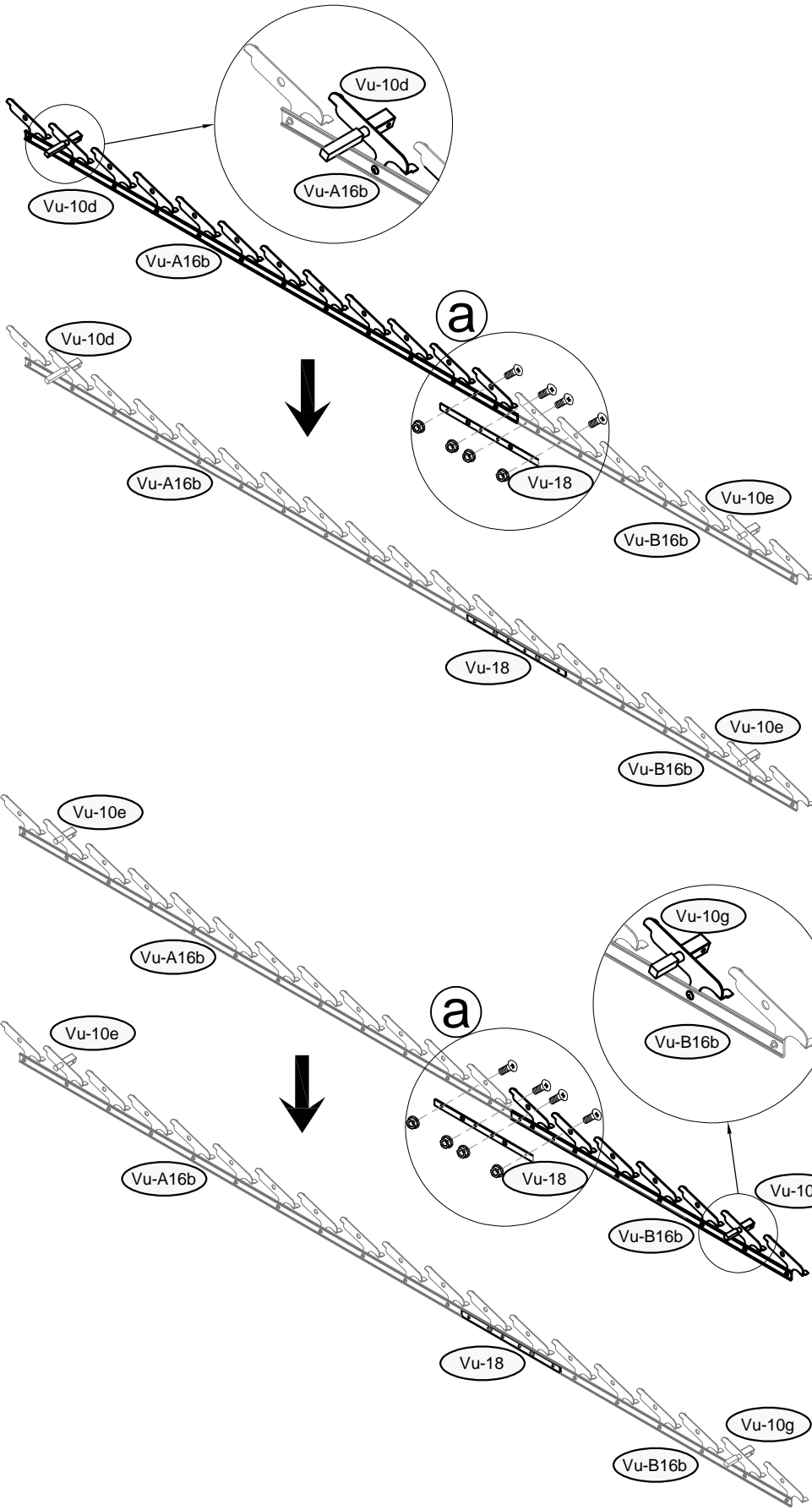

<p>22</p>	 <p>Vu-18 x2</p>	 <p>Vu-K43 x8</p>	 <p>Vu-K44 x8</p>	
-----------	---	--	--	--



<p>23</p>	 <p>Vu-18 x4</p>	 <p>Vu-K43 x16</p>	 <p>Vu-K44 x16</p>
------------------	---	---	---

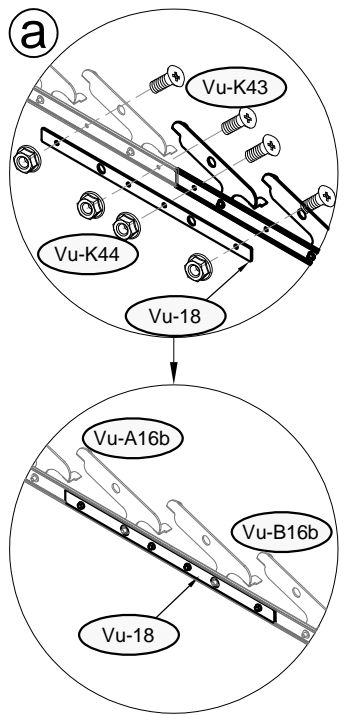
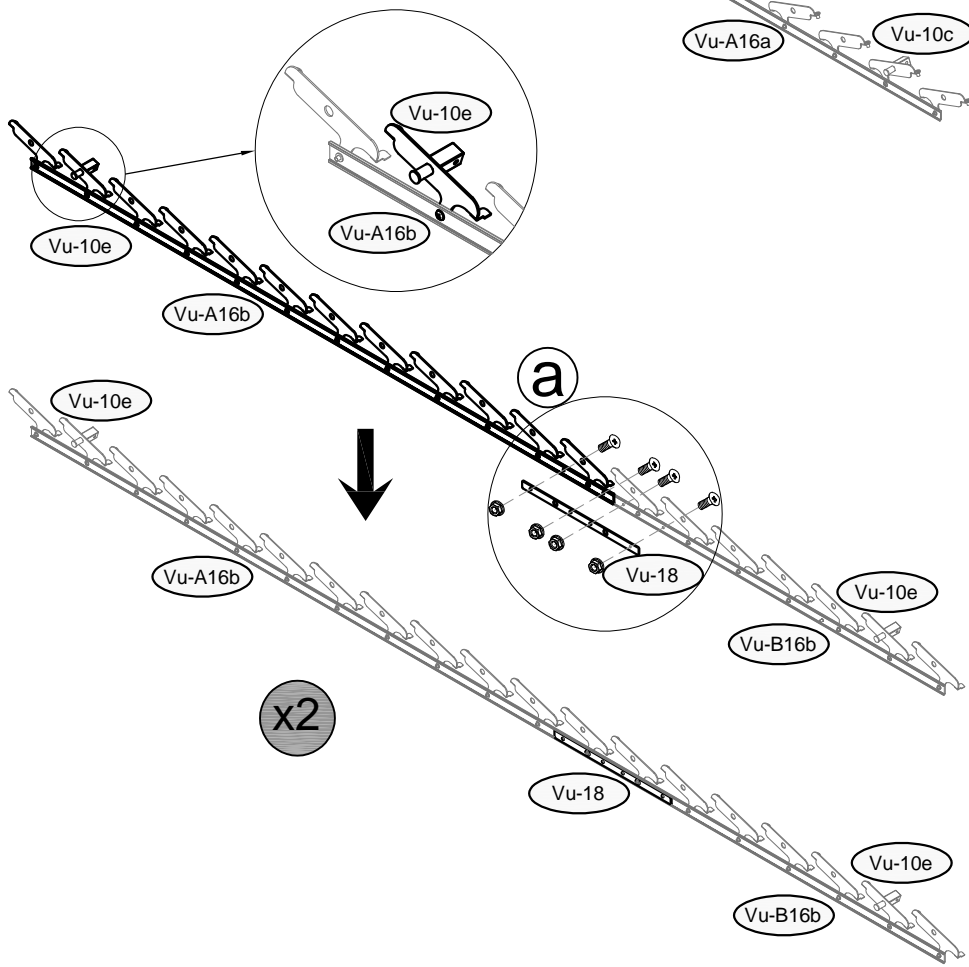
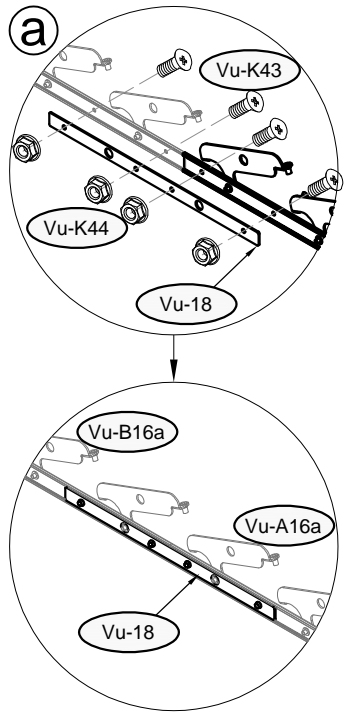
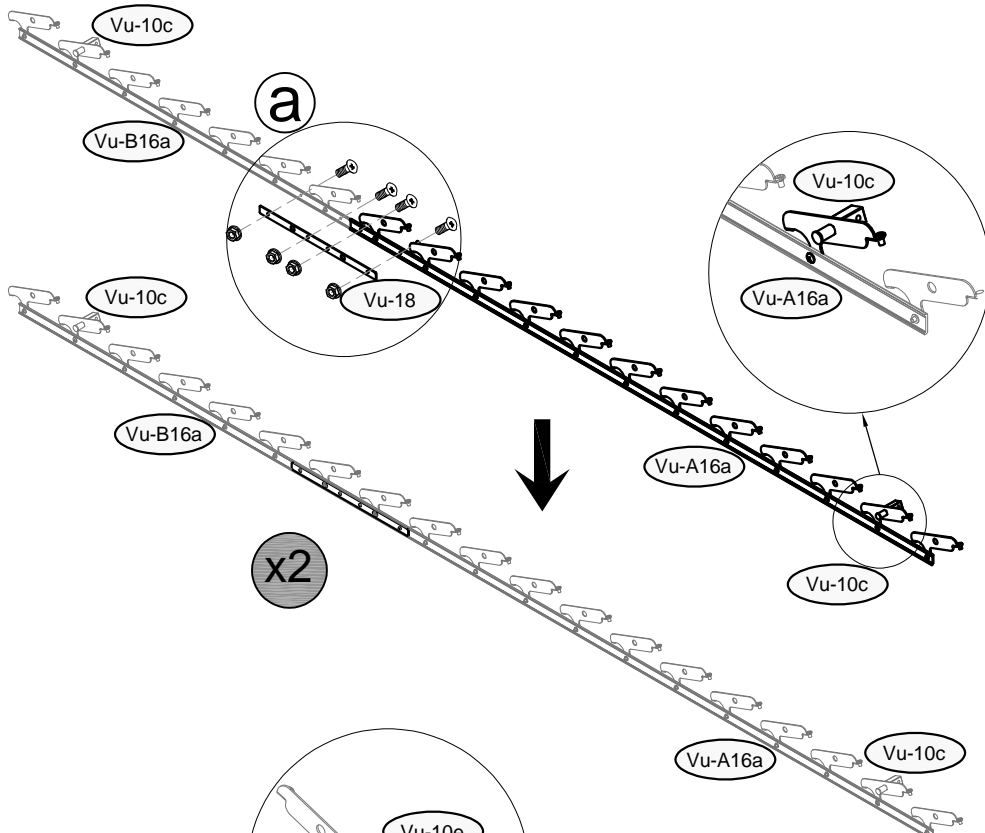

24	 Vu-21 x34	 Vu-K41 x34
-----------	--	---

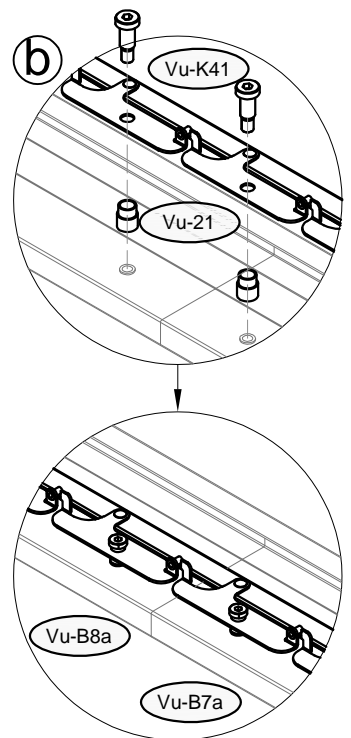
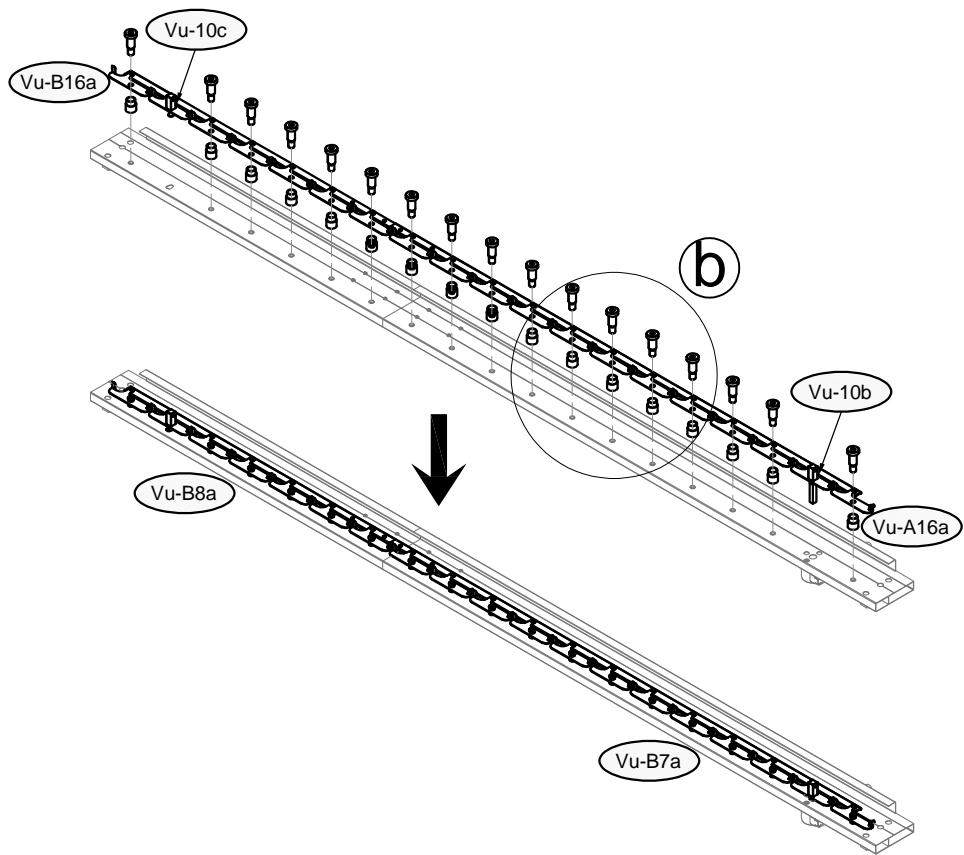
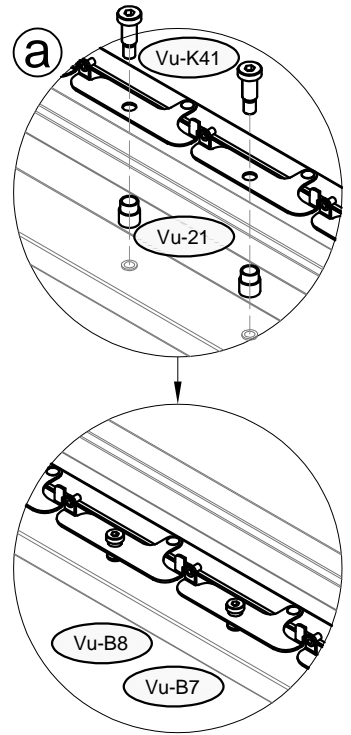
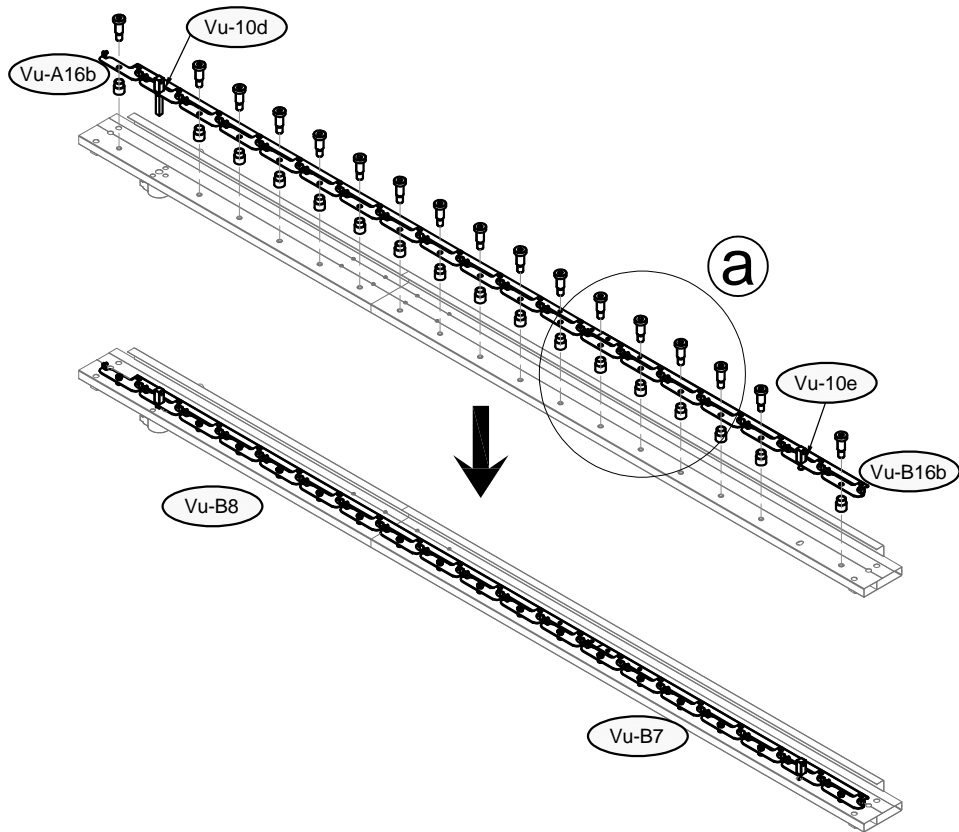

25







Vu-21 x68

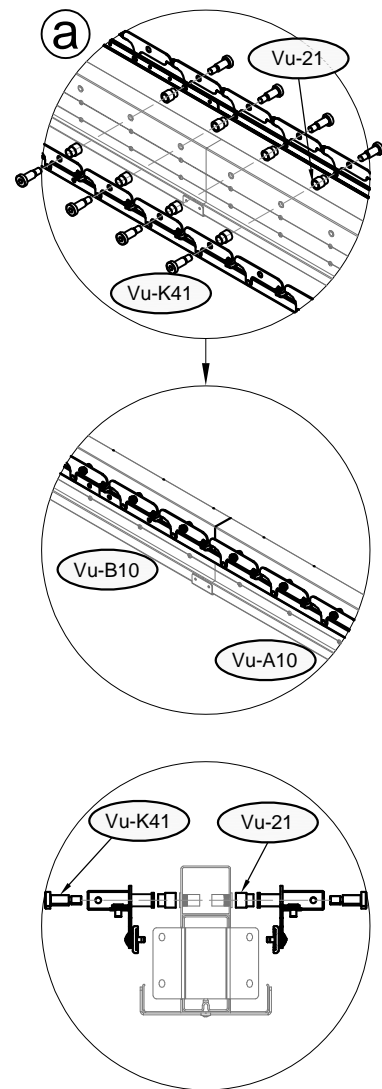
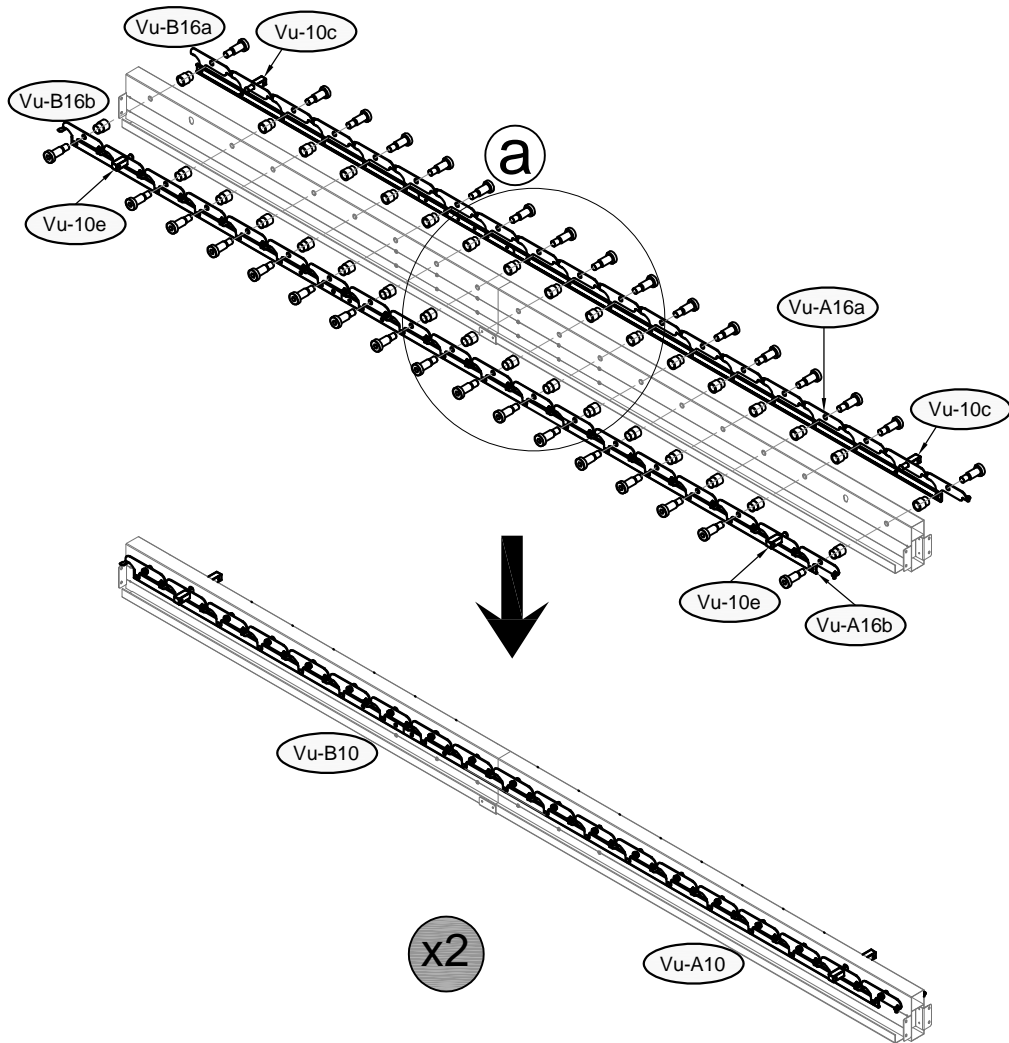

Vu-K41 x68



26	 Vu-14b x2	 Vu-21 x34	 Vu-K34 x4	 Vu-K41 x34
----	--	--	--	---

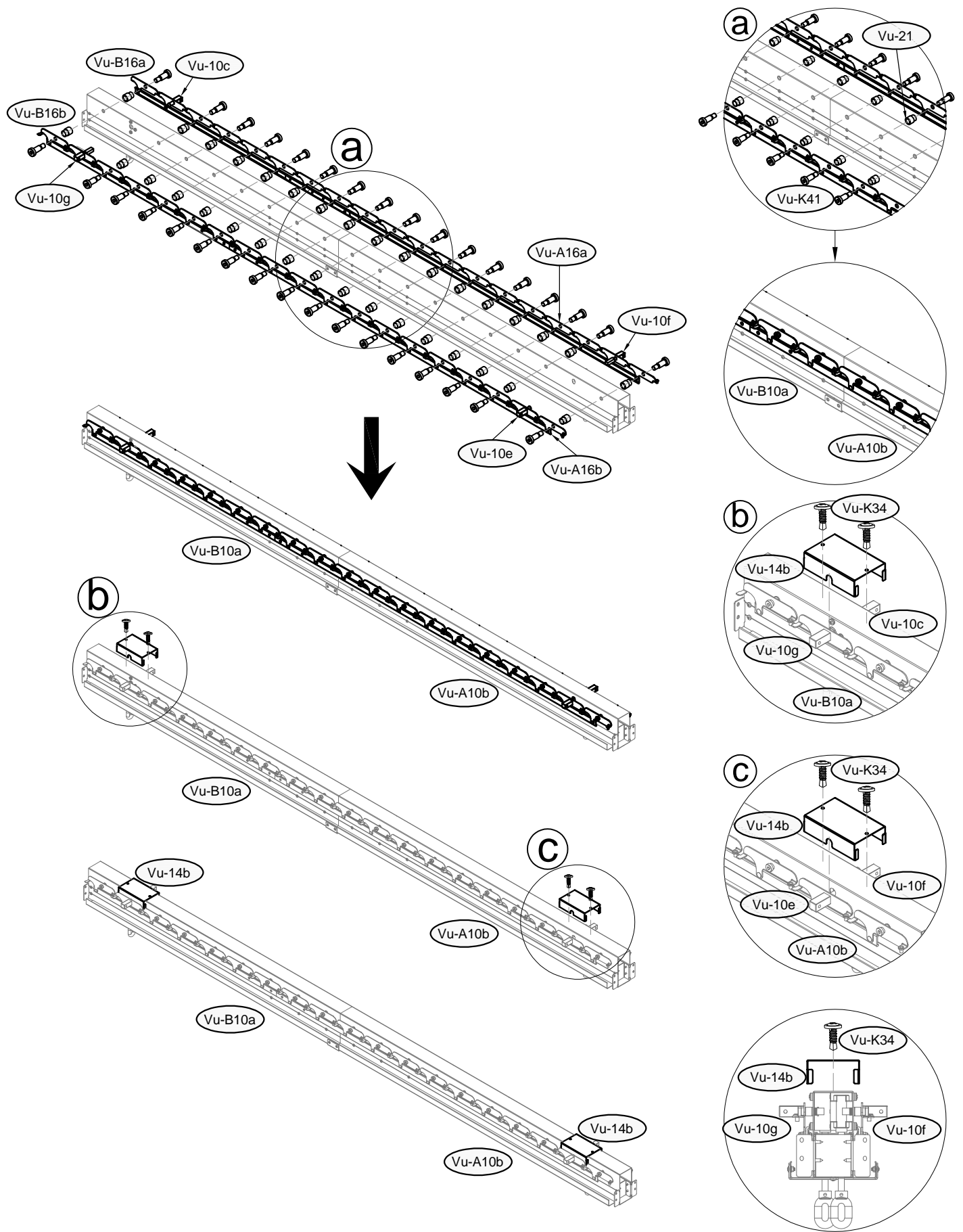

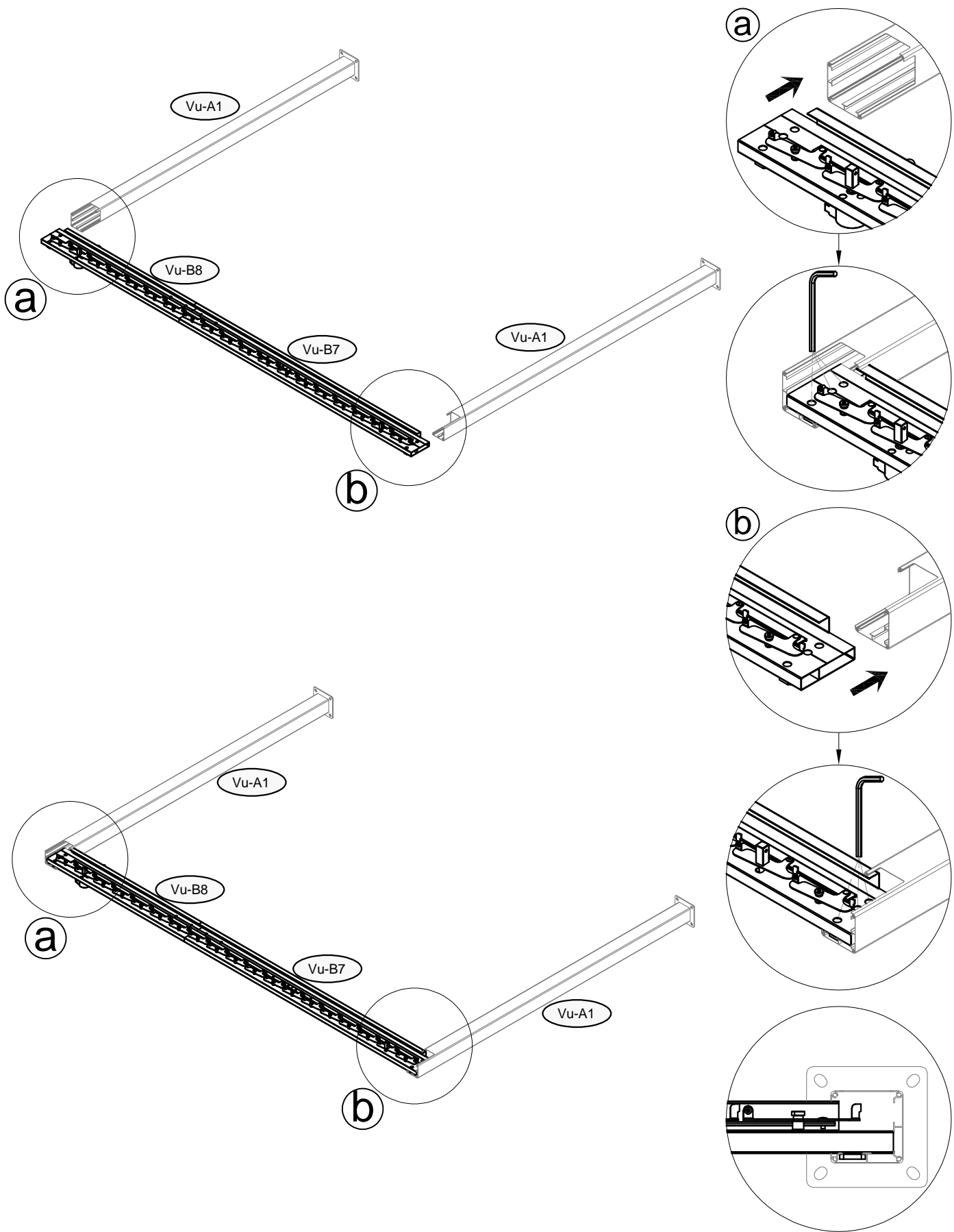

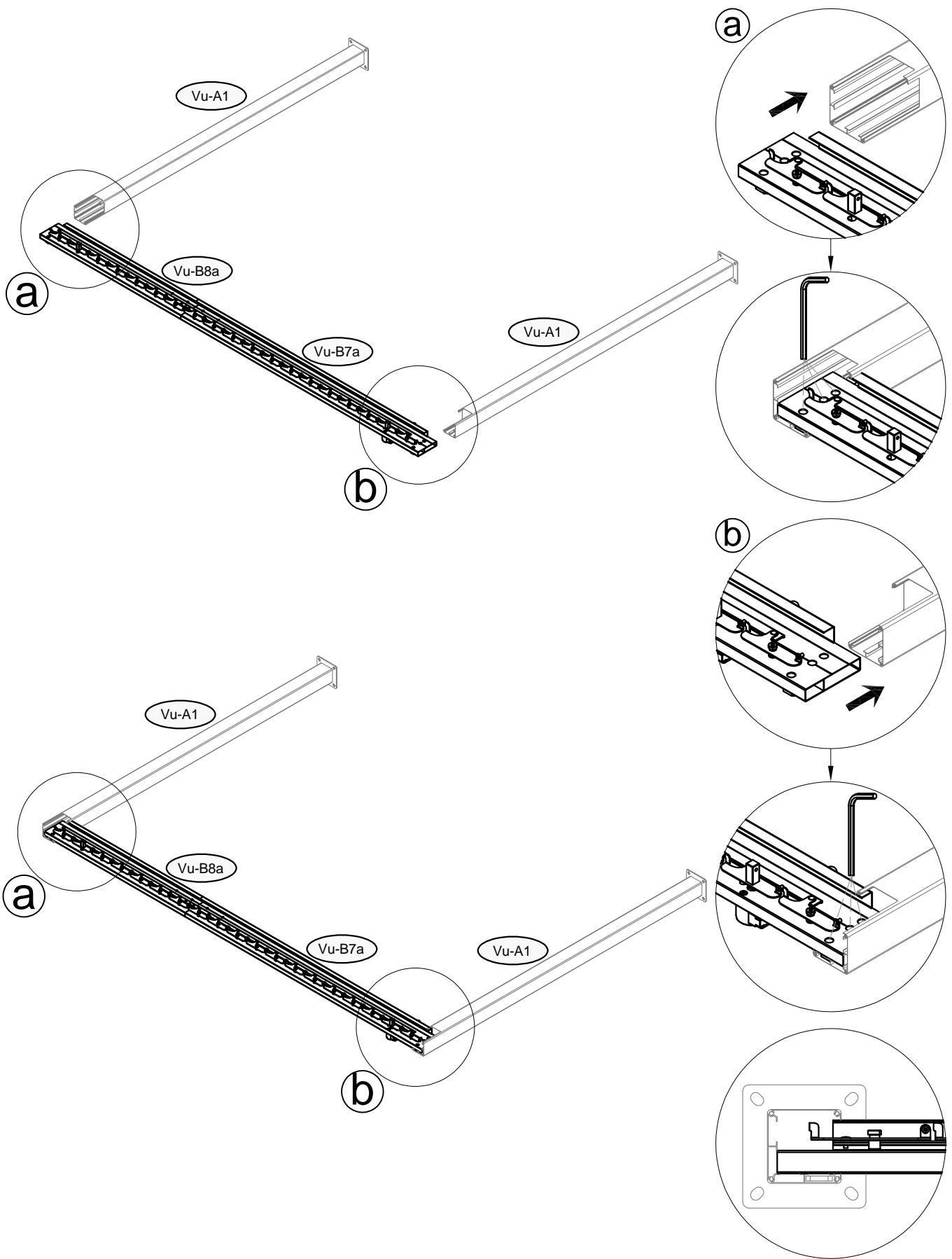

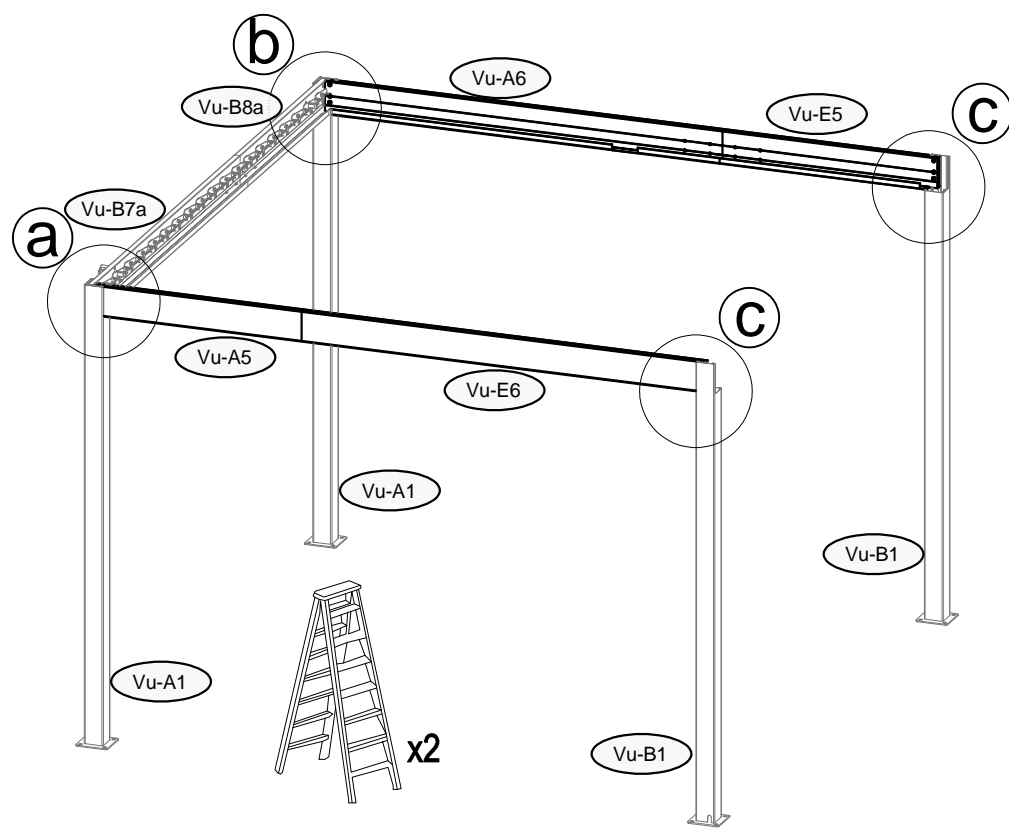
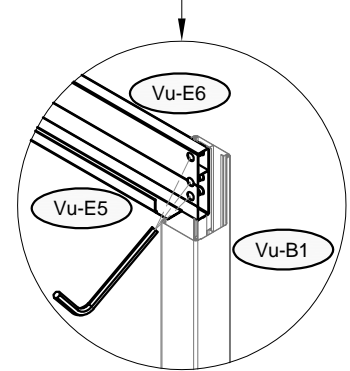
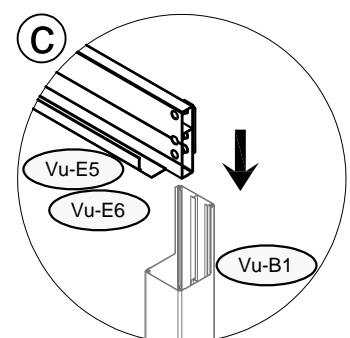
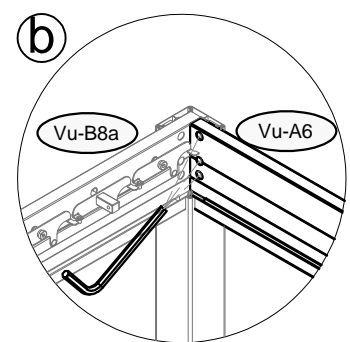
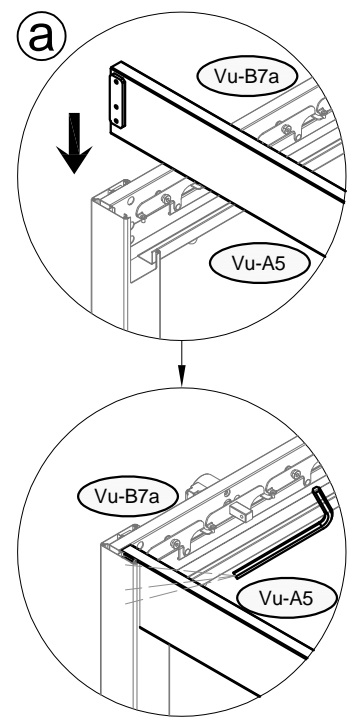
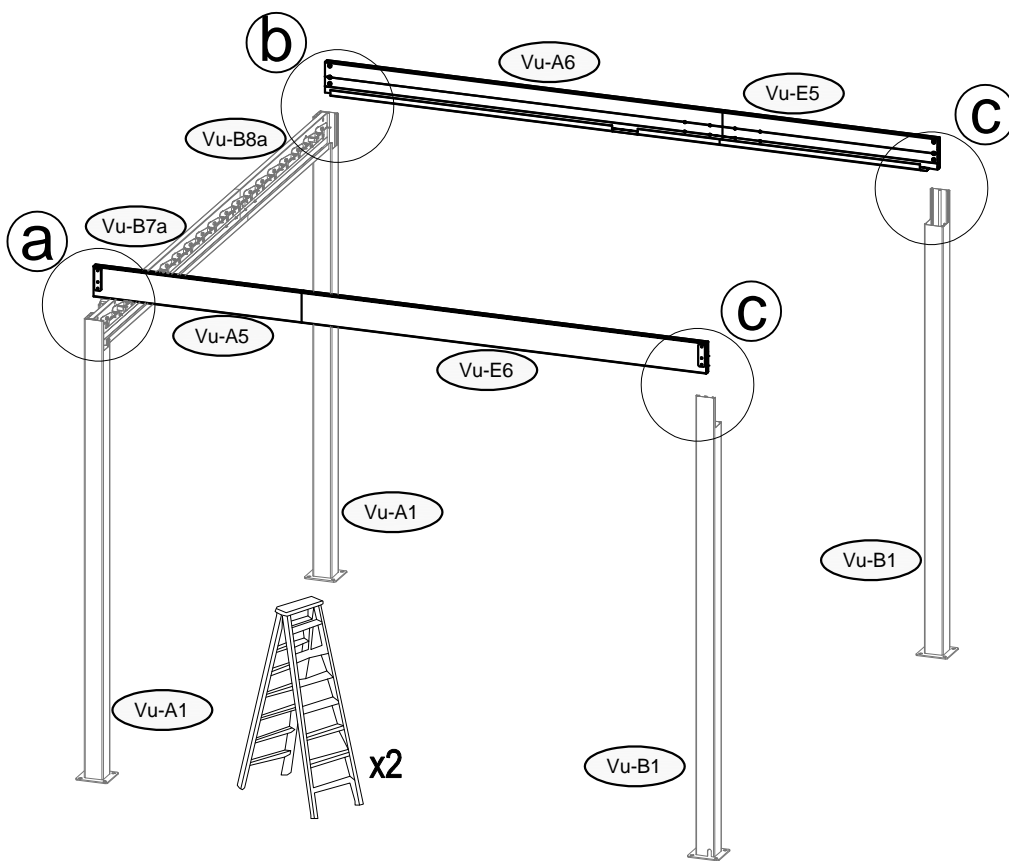

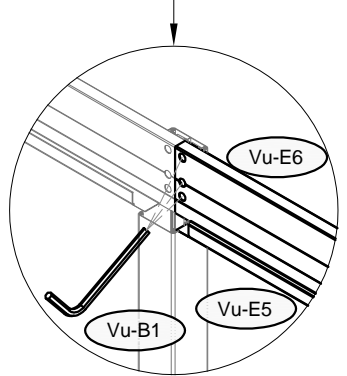
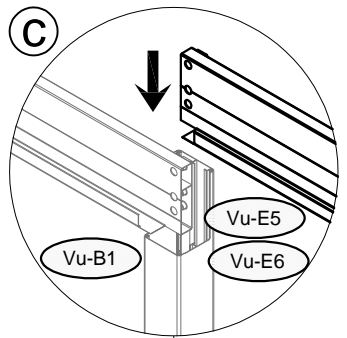
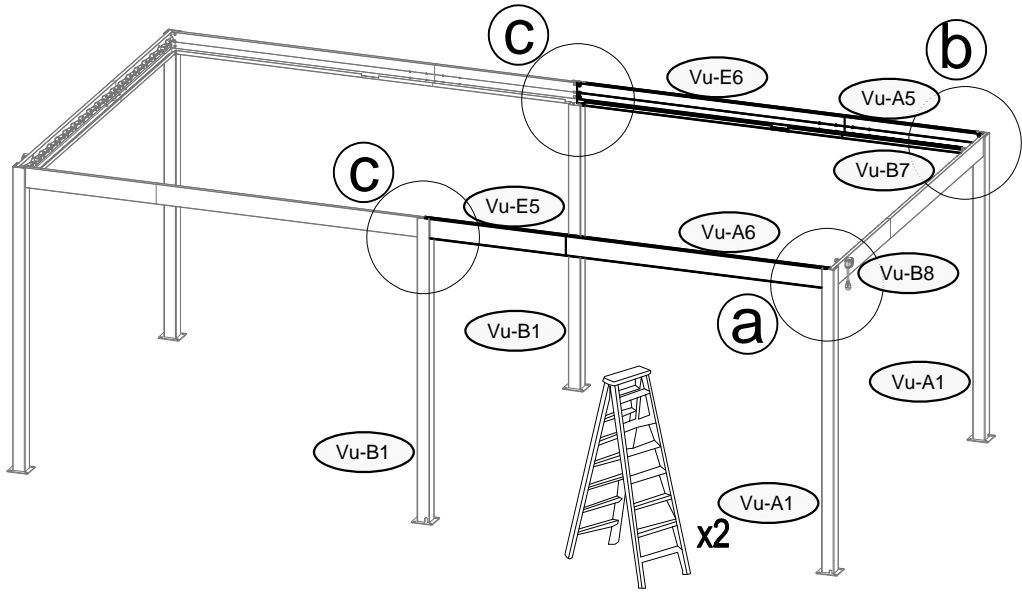
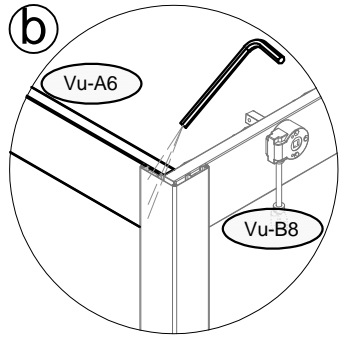
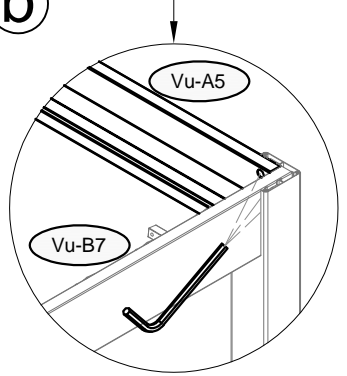
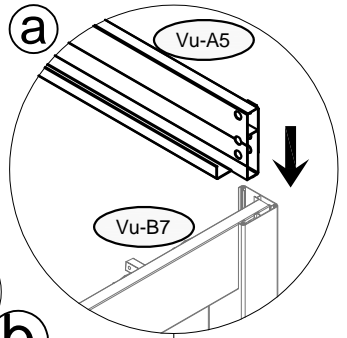
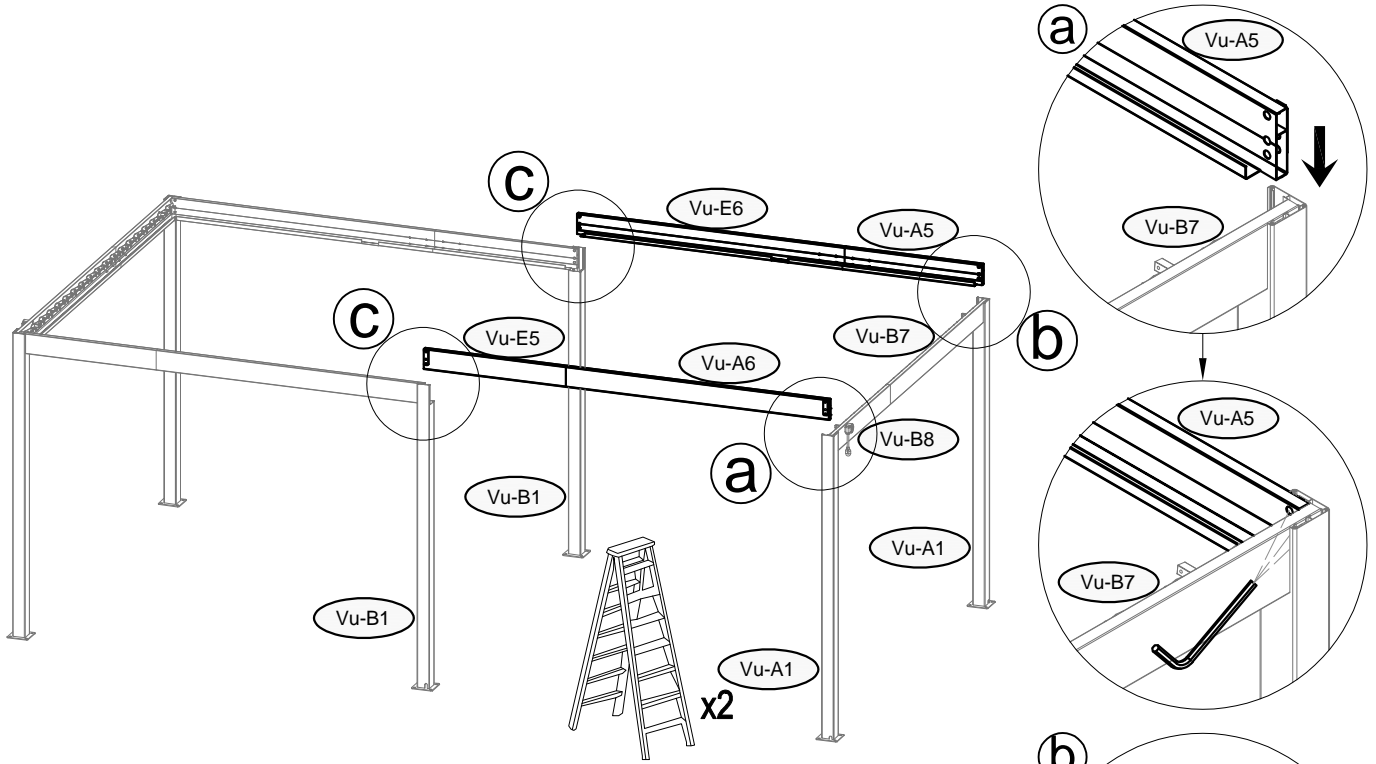

31



Vu-K45 x24

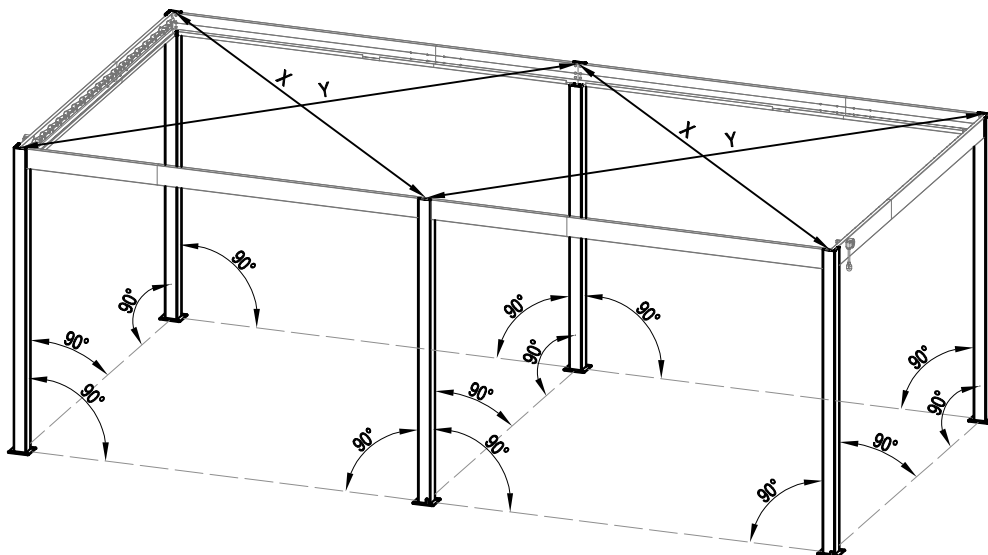

$X=Y$

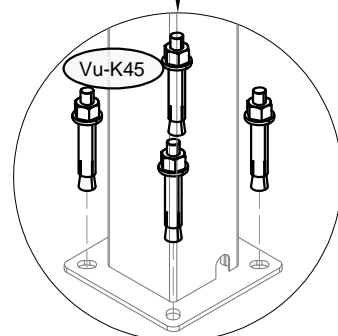
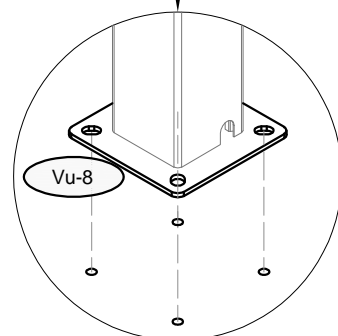
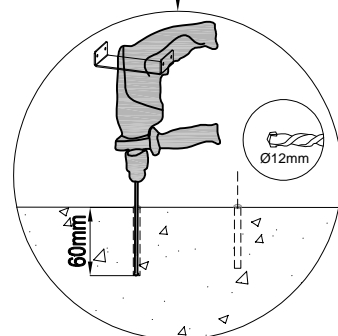
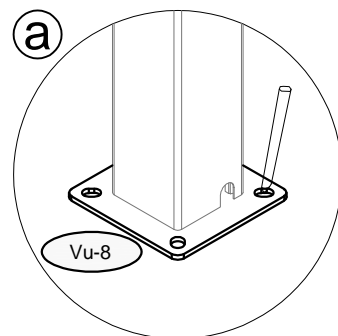
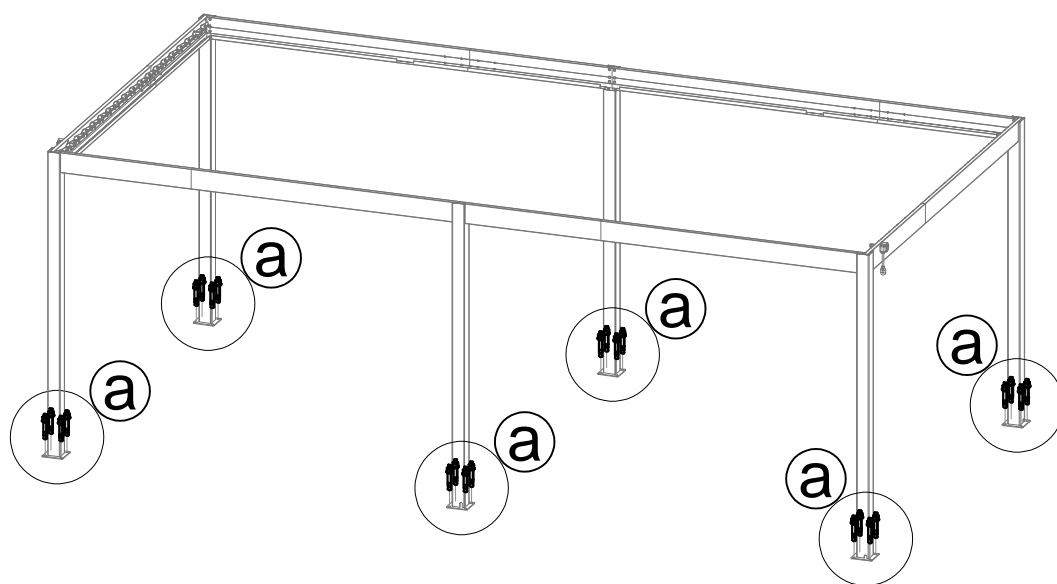

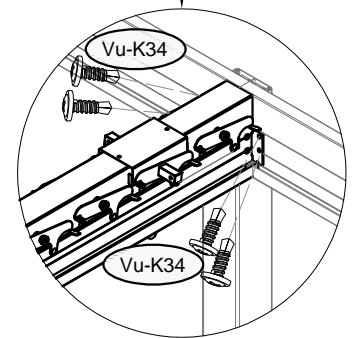
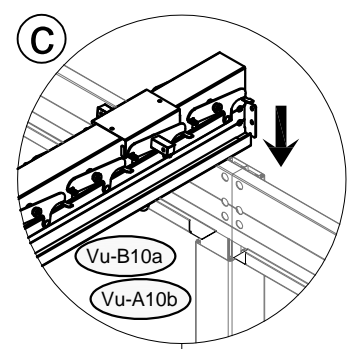
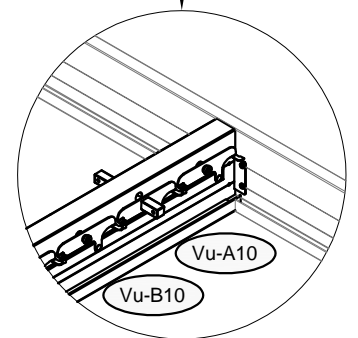
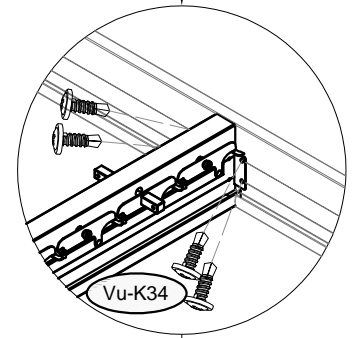
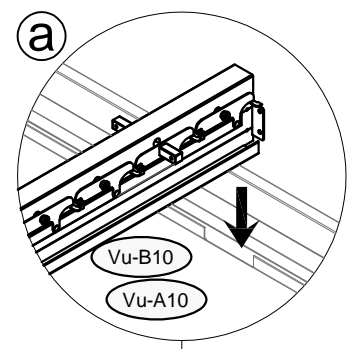
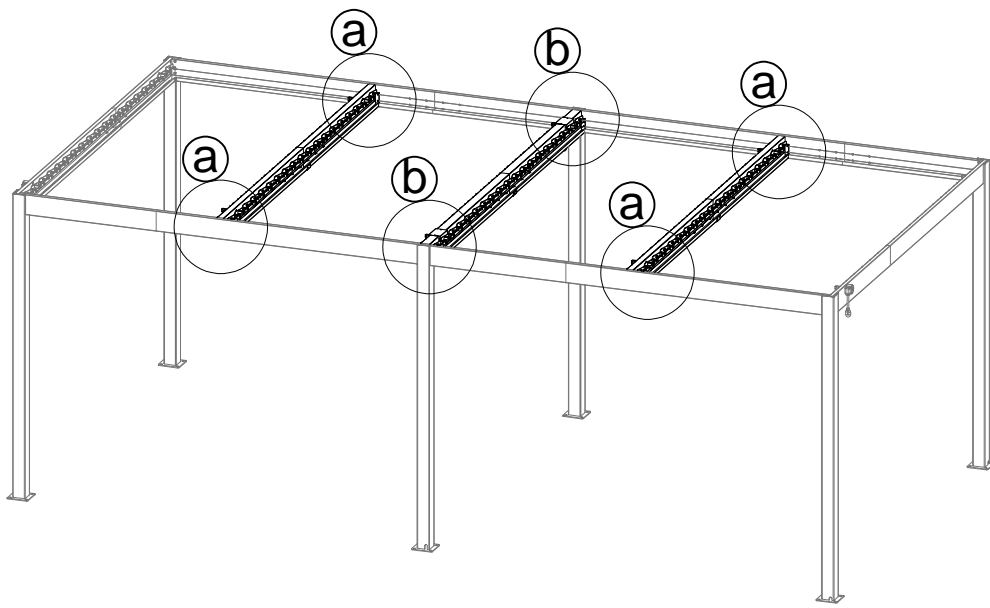
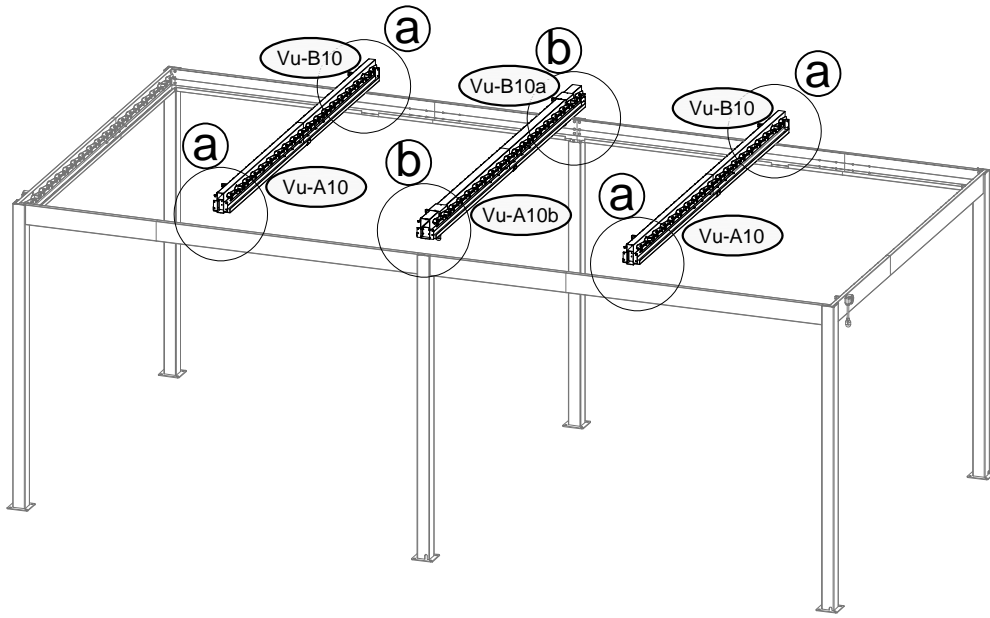

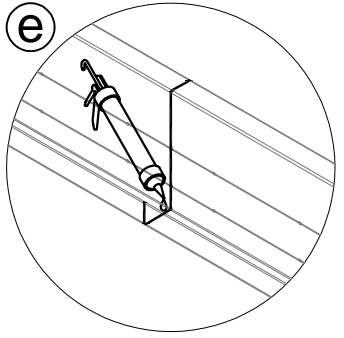
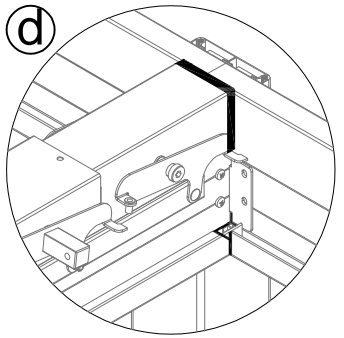
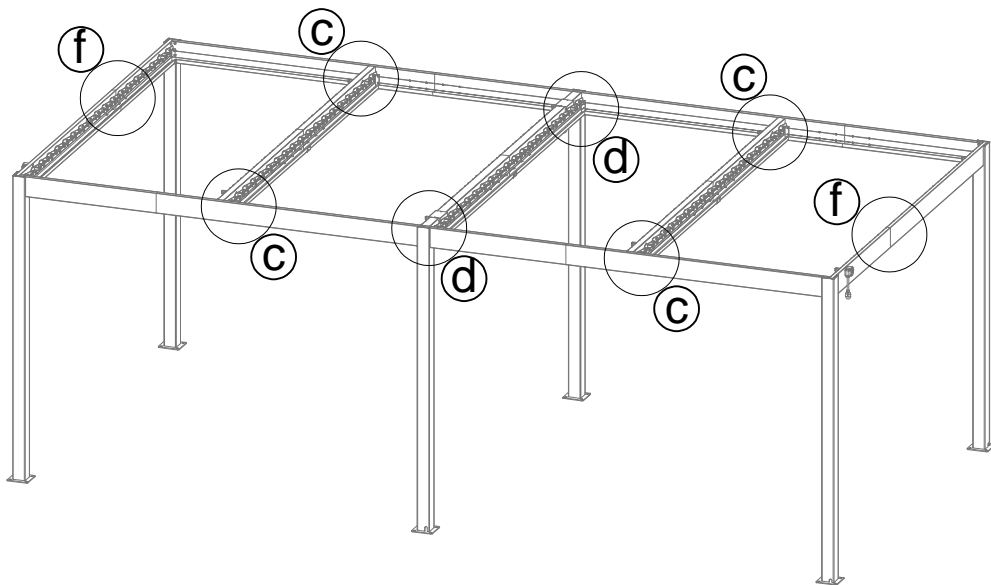
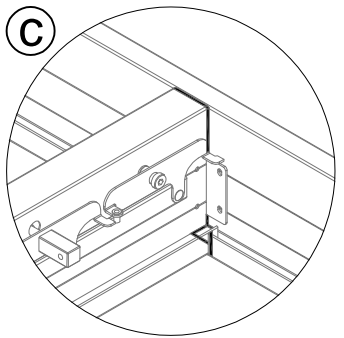
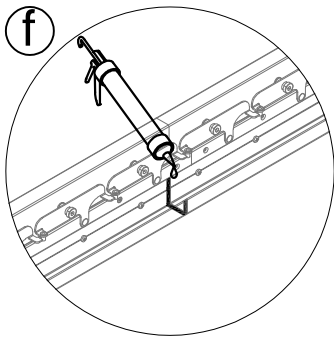
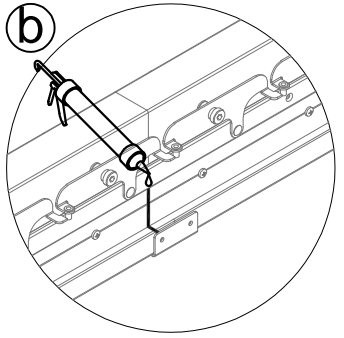
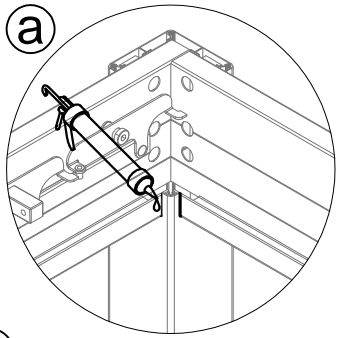
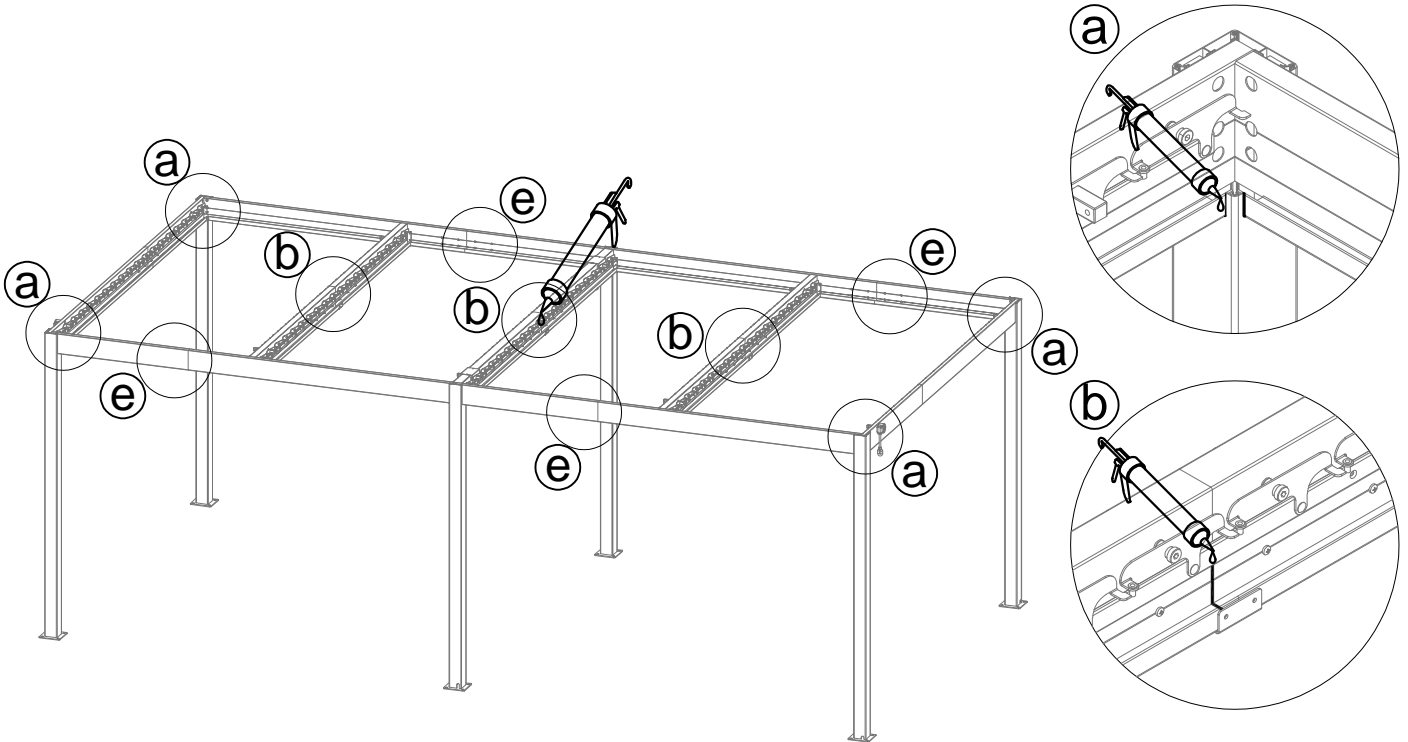

34



Vu-A15 x76



Vu-26 x152

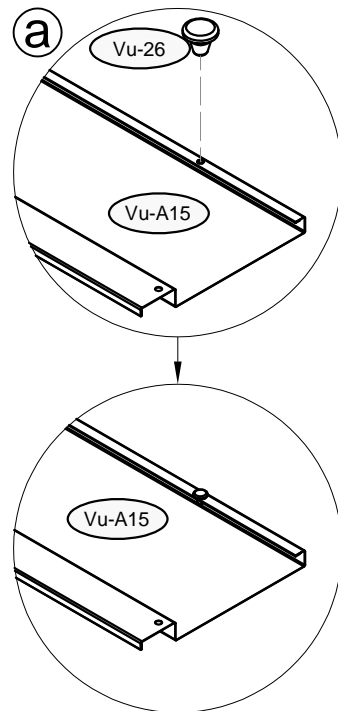
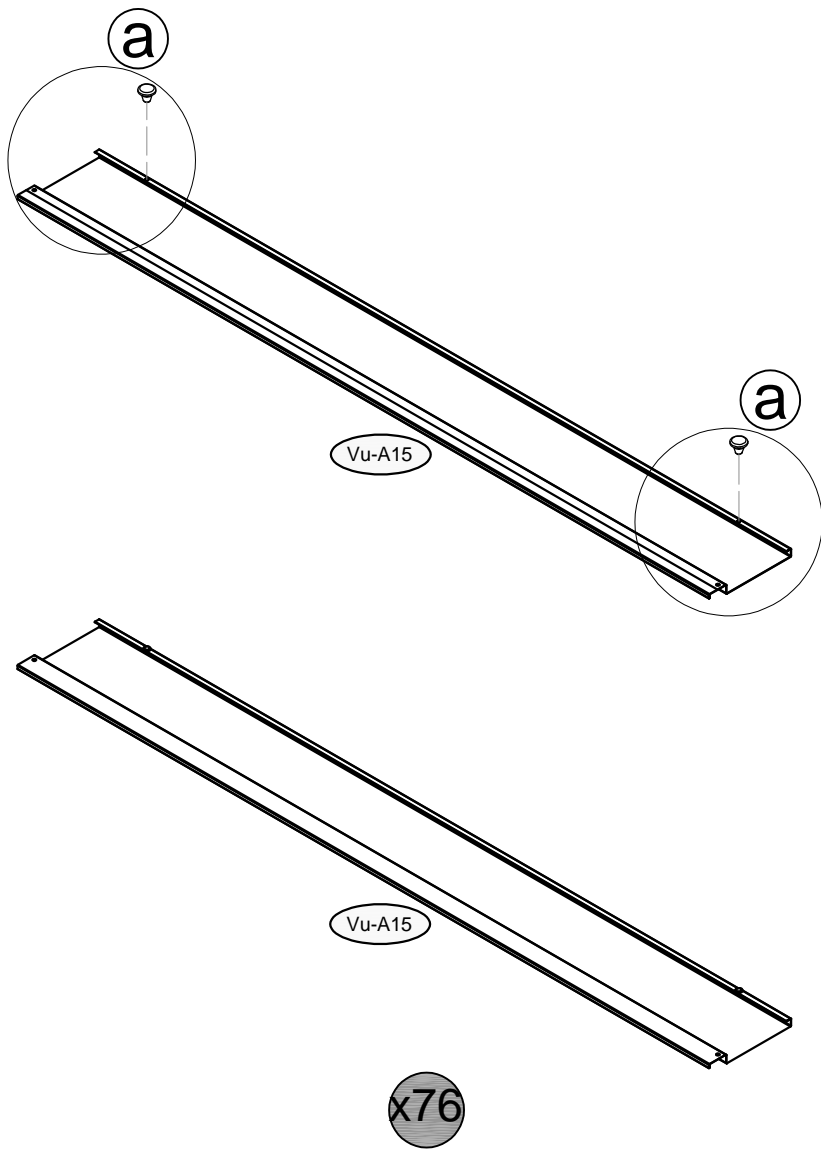

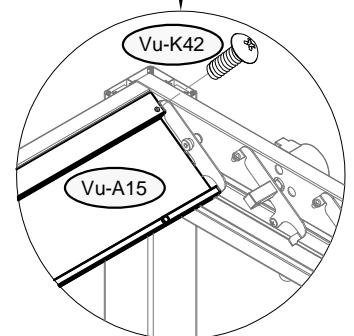
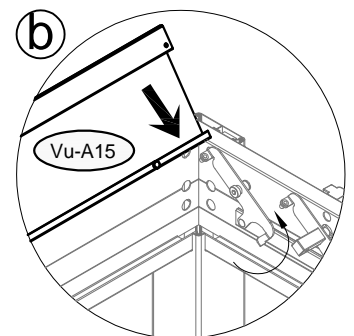
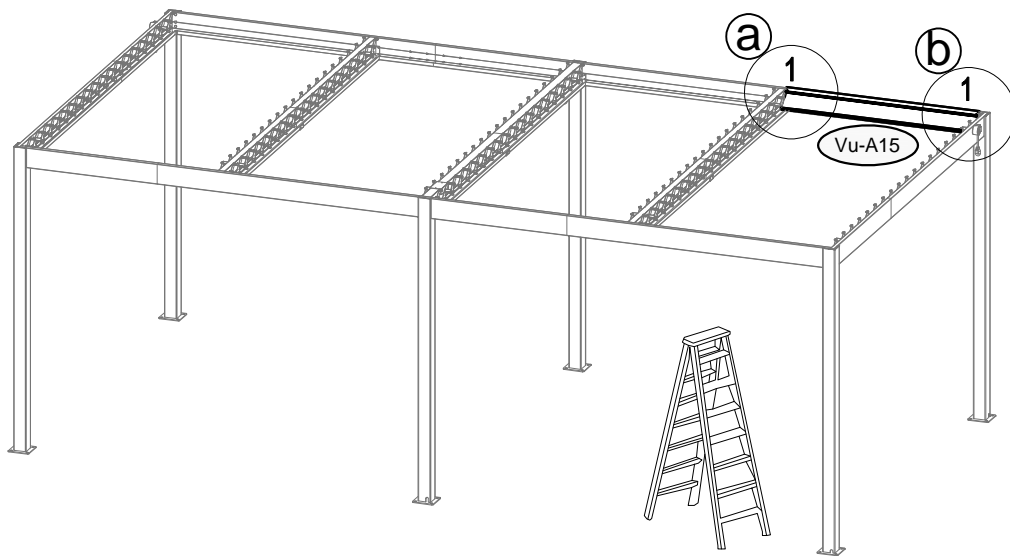
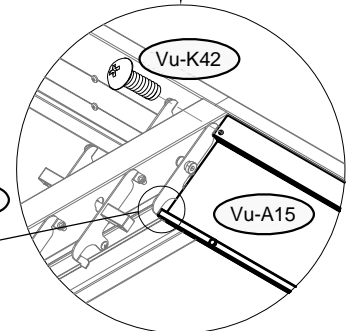
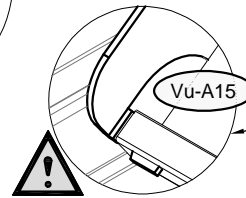
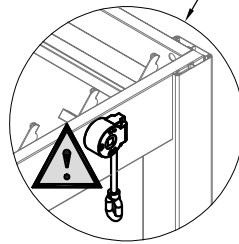
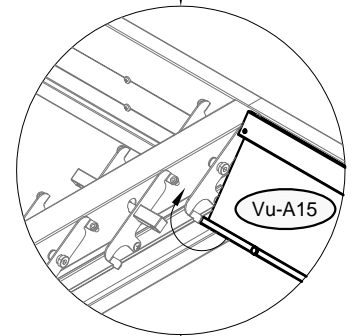
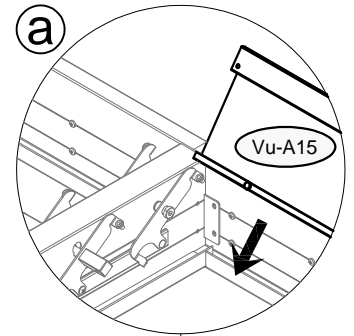
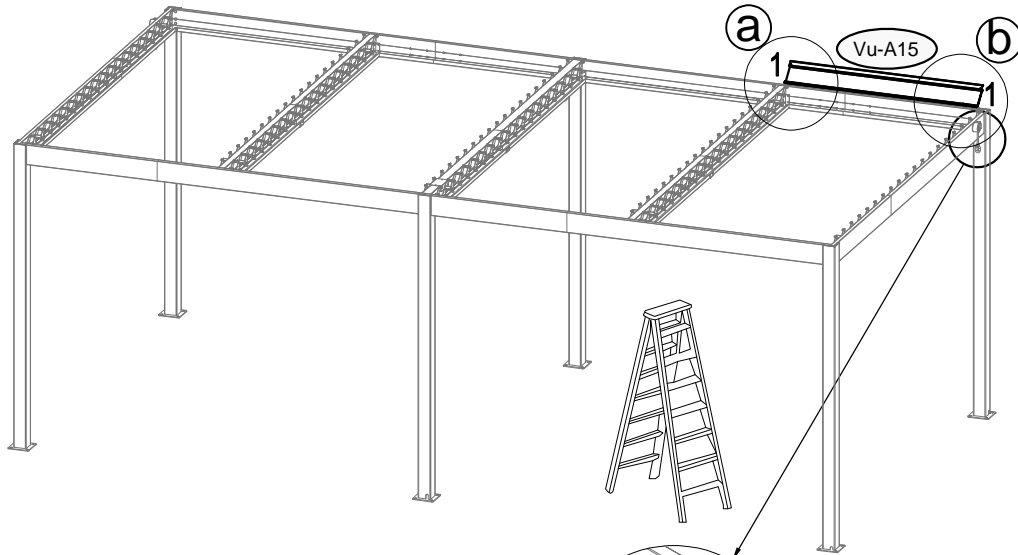

36



Vu-K42 x36

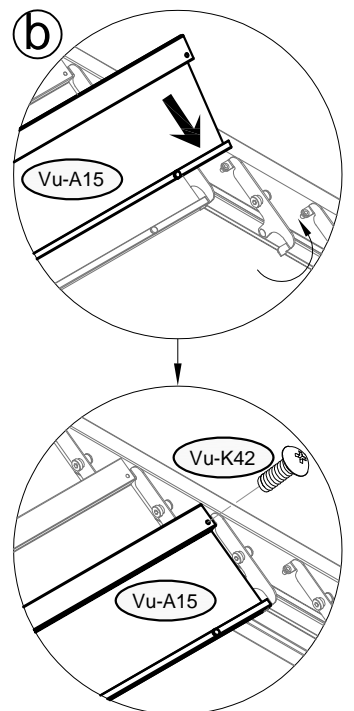
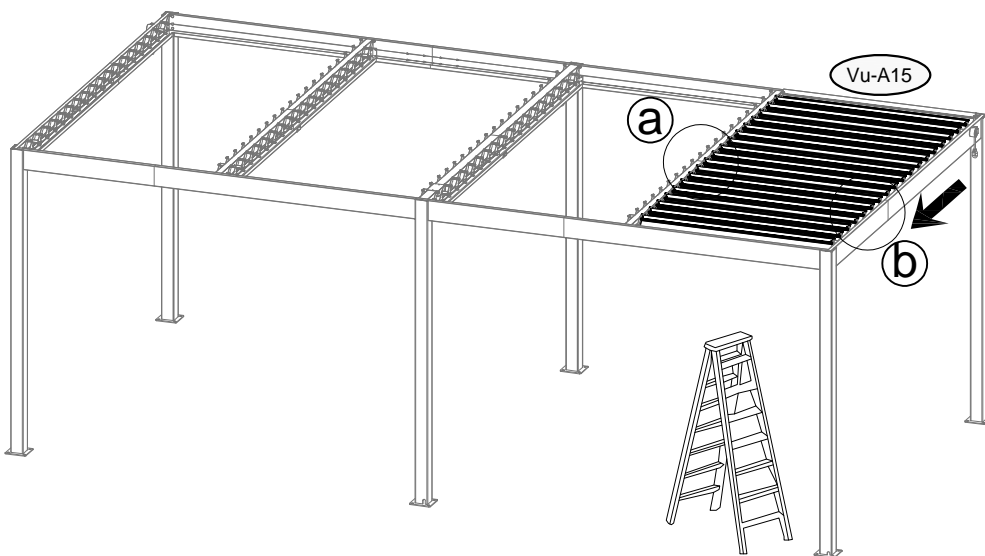
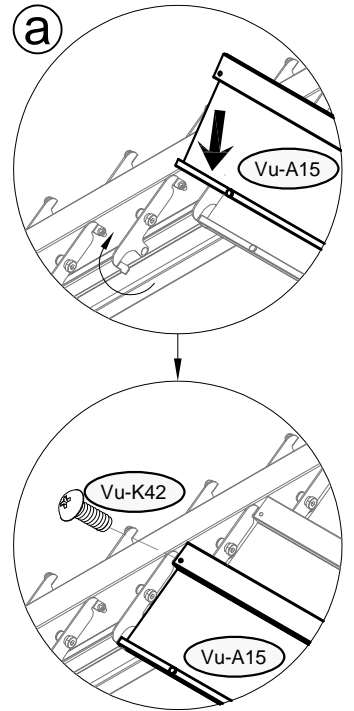
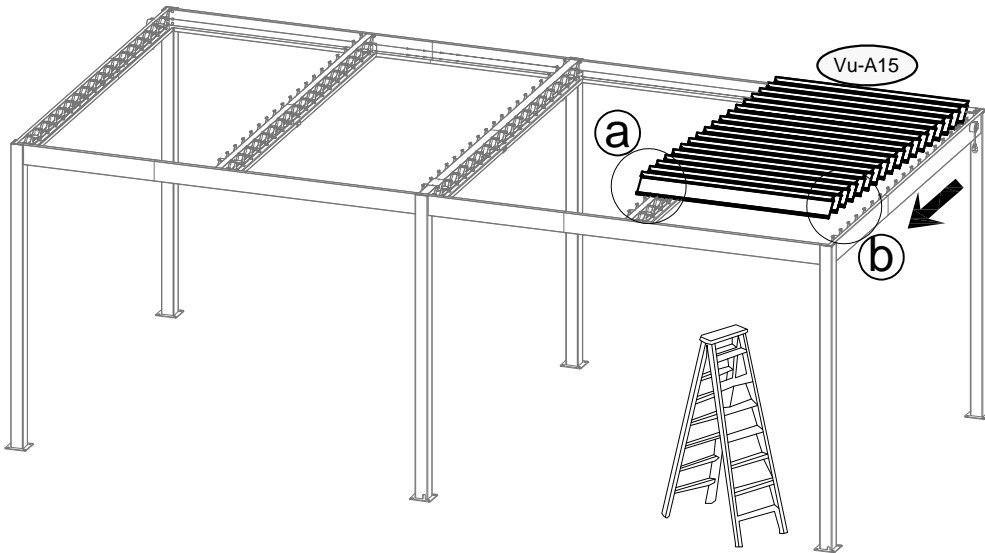

37



Vu-K42 x2

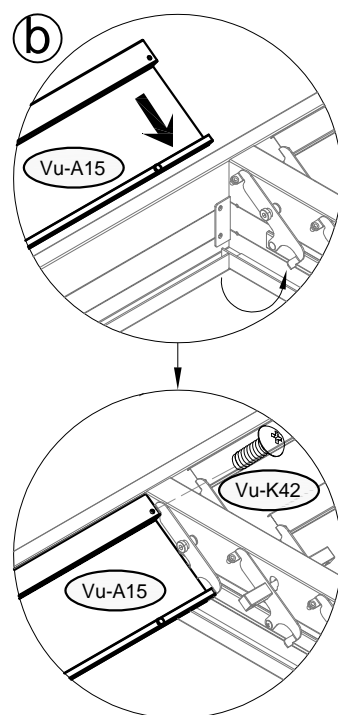
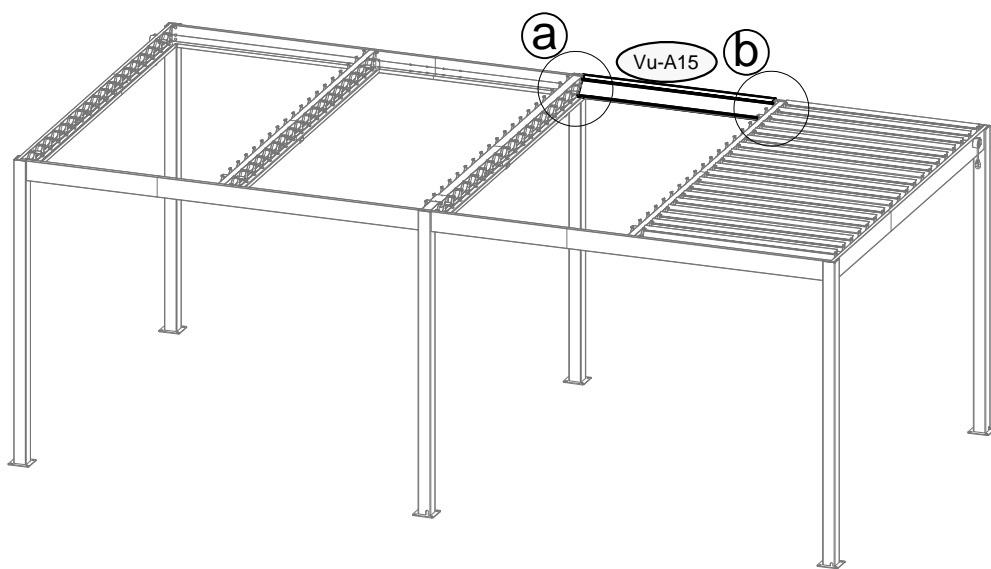
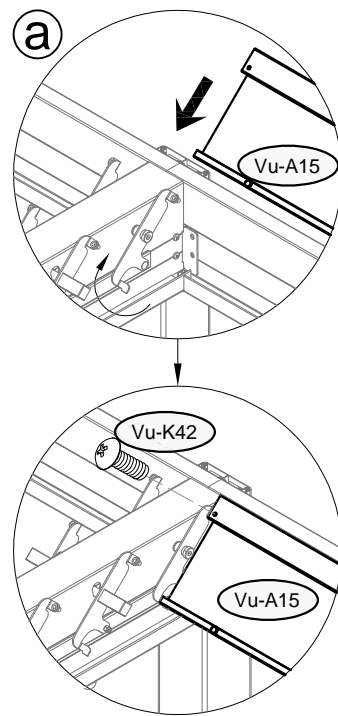
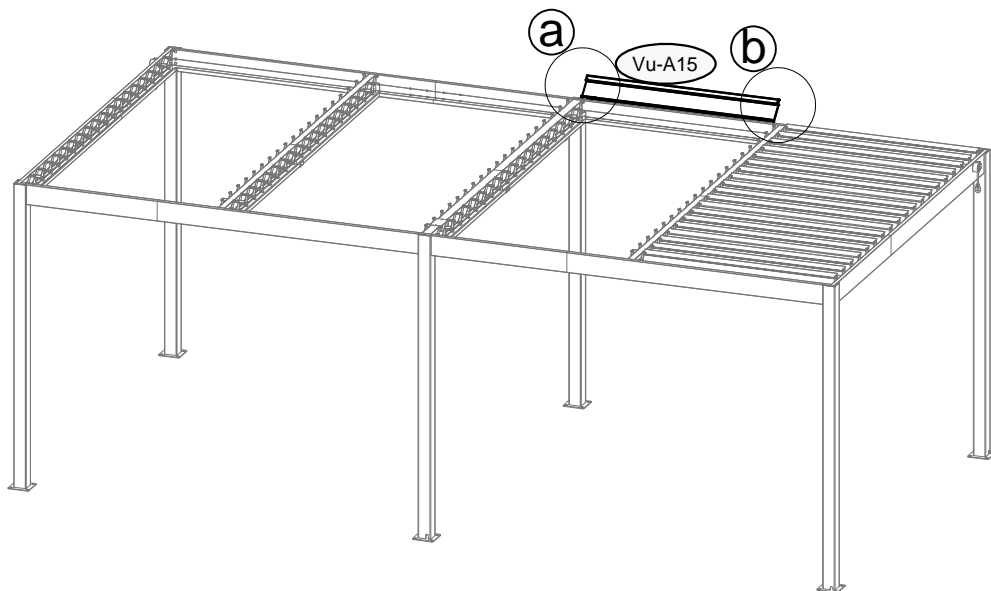

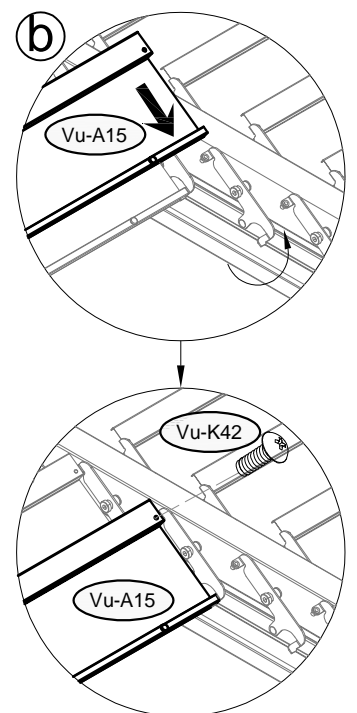
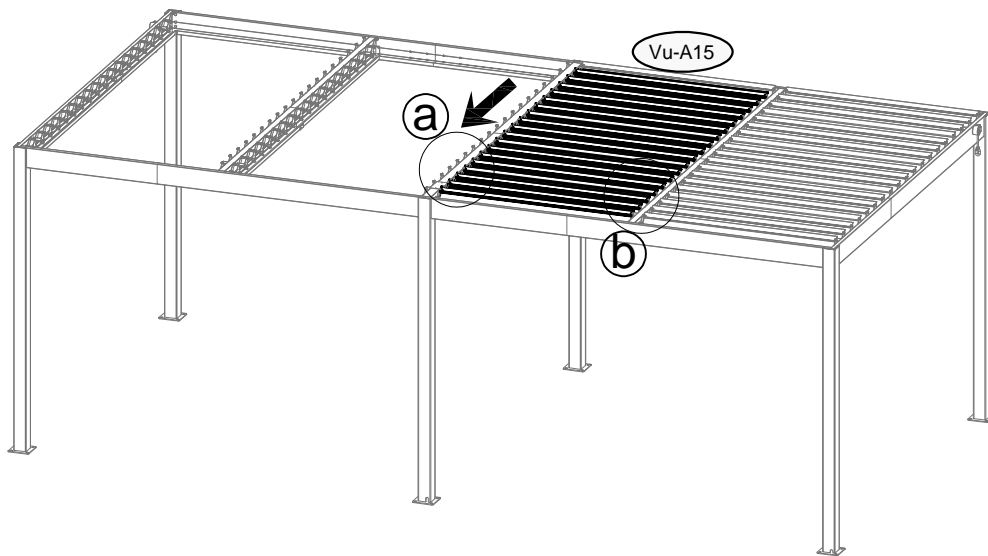
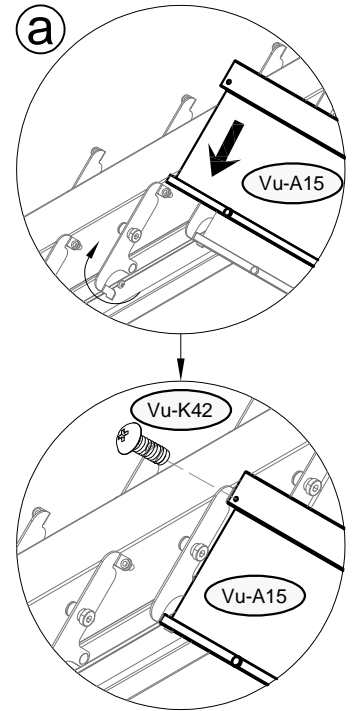
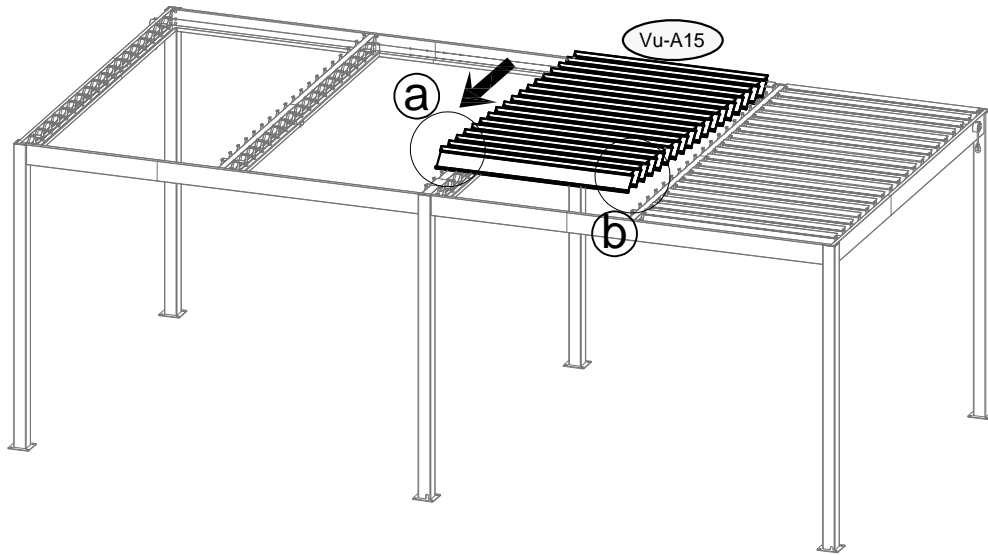

39



Vu-K42 x2

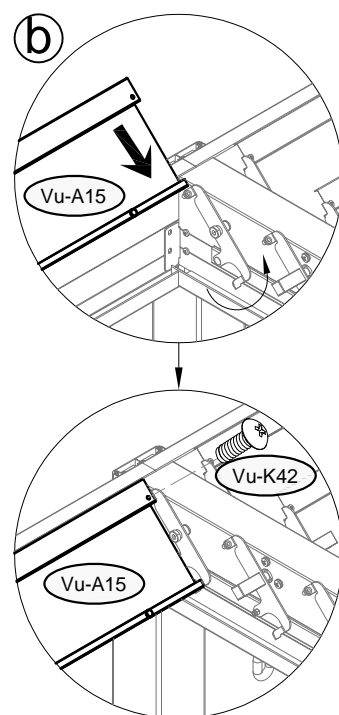
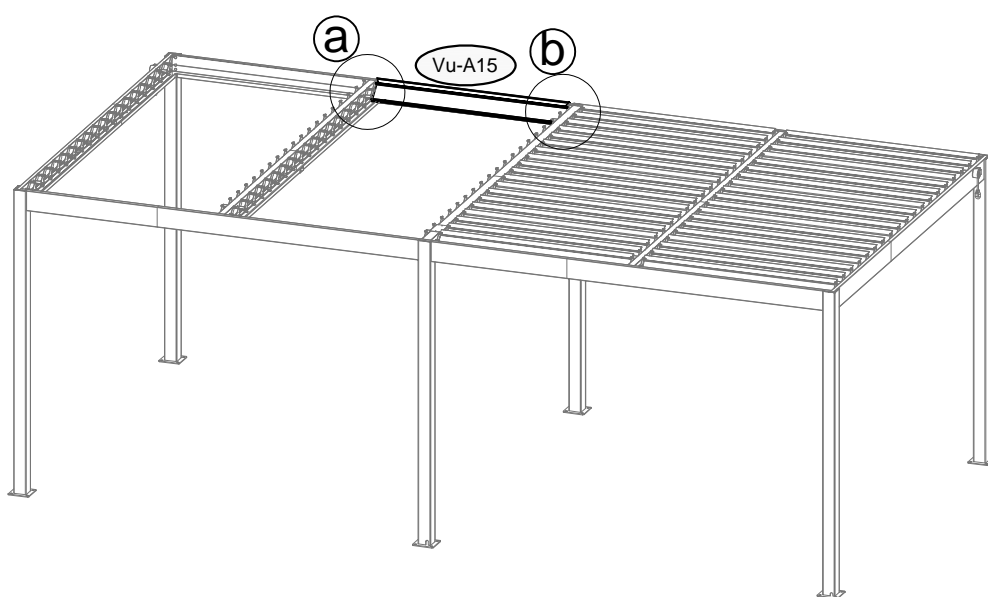
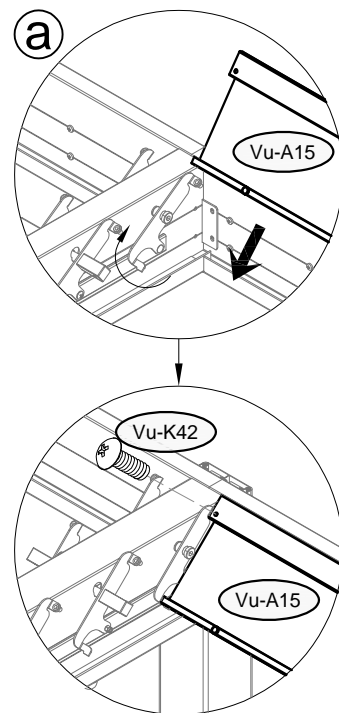
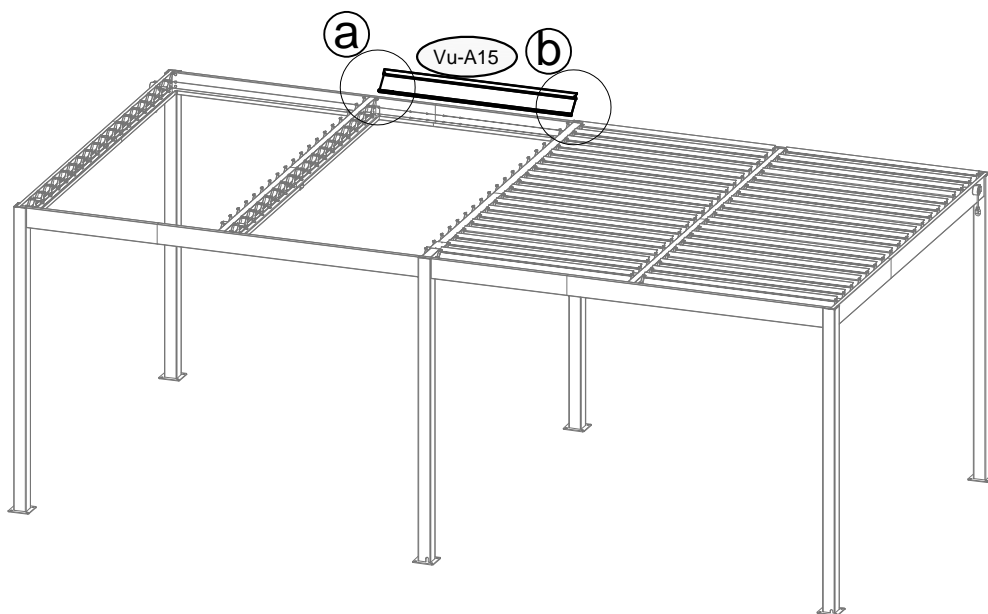

40



Vu-K42 x36

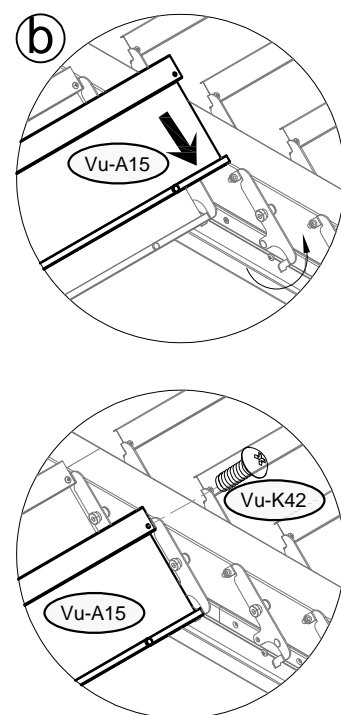
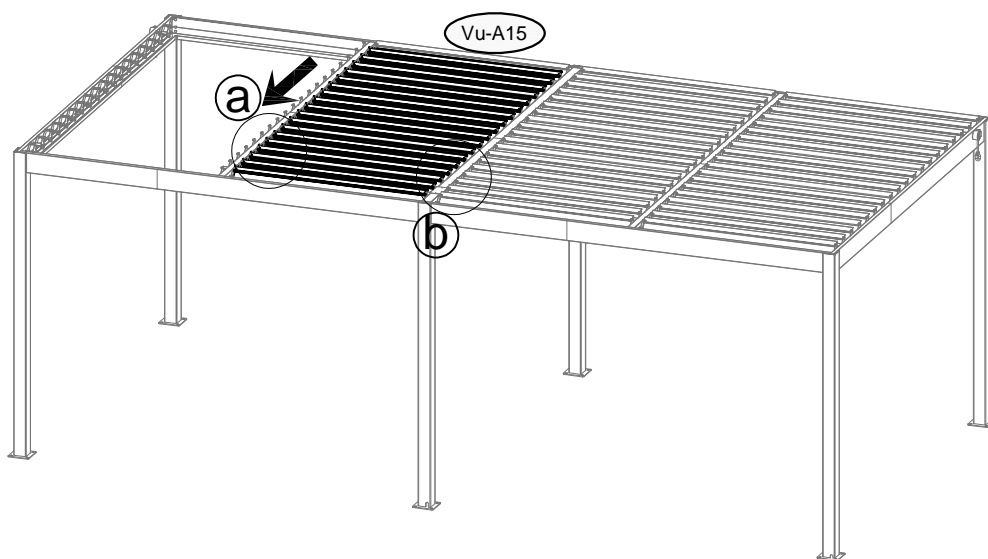
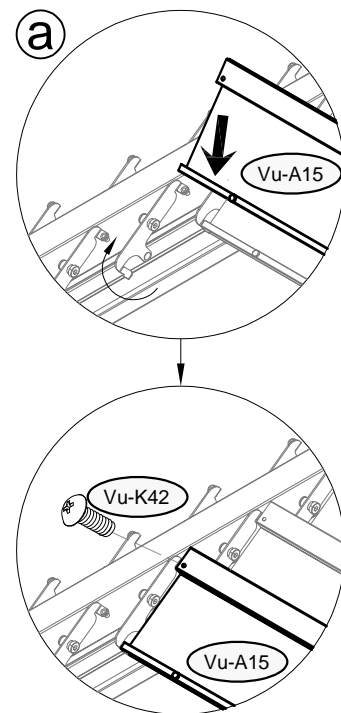
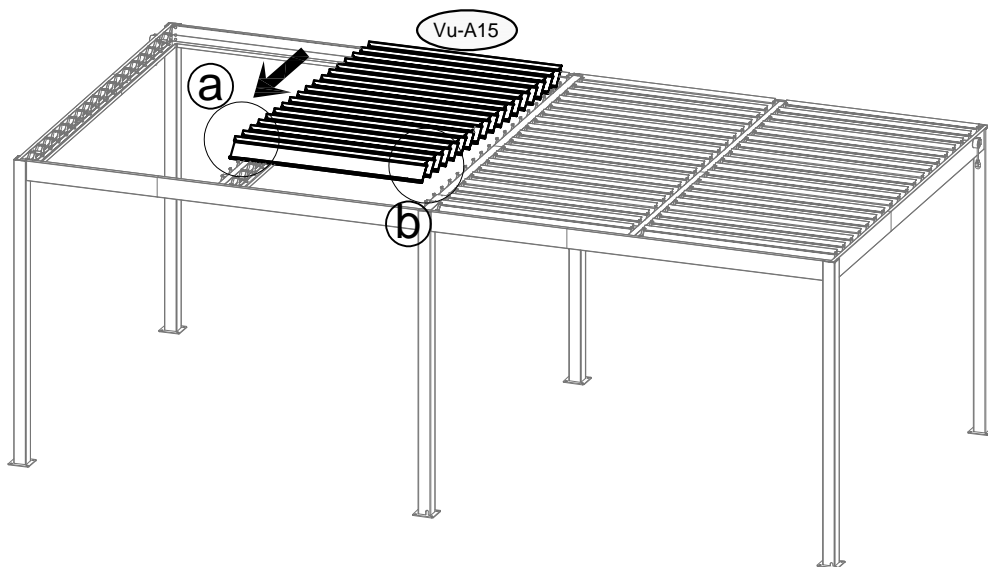

41



Vu-K42 x2

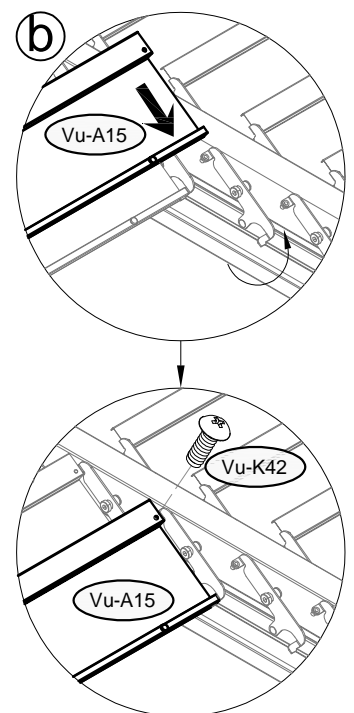
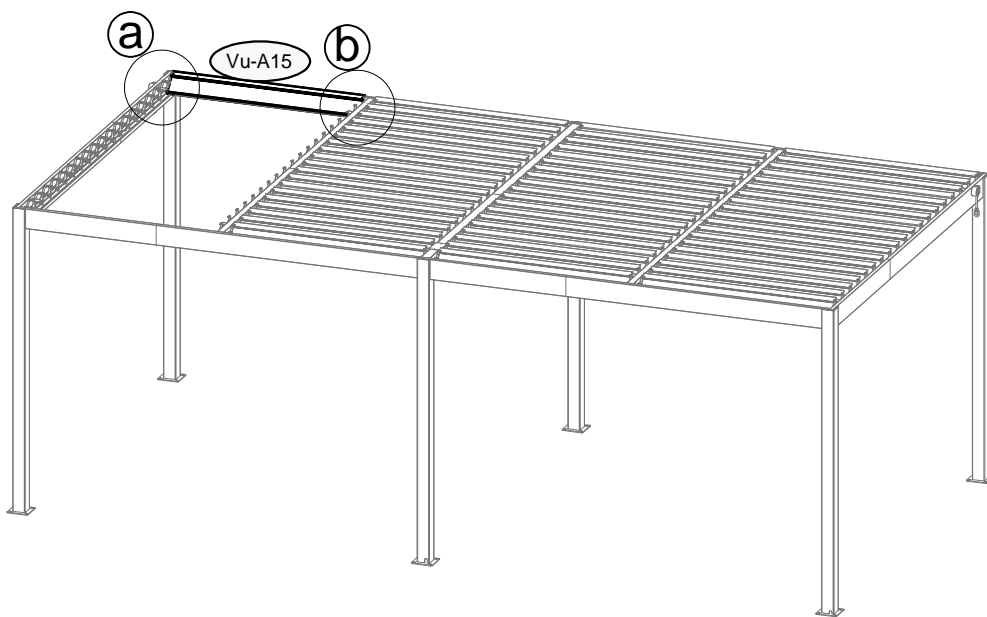
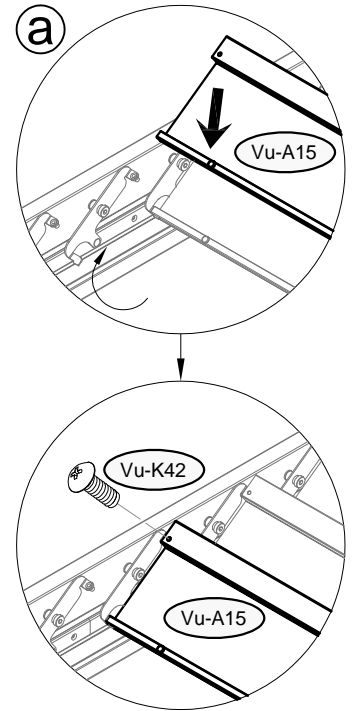
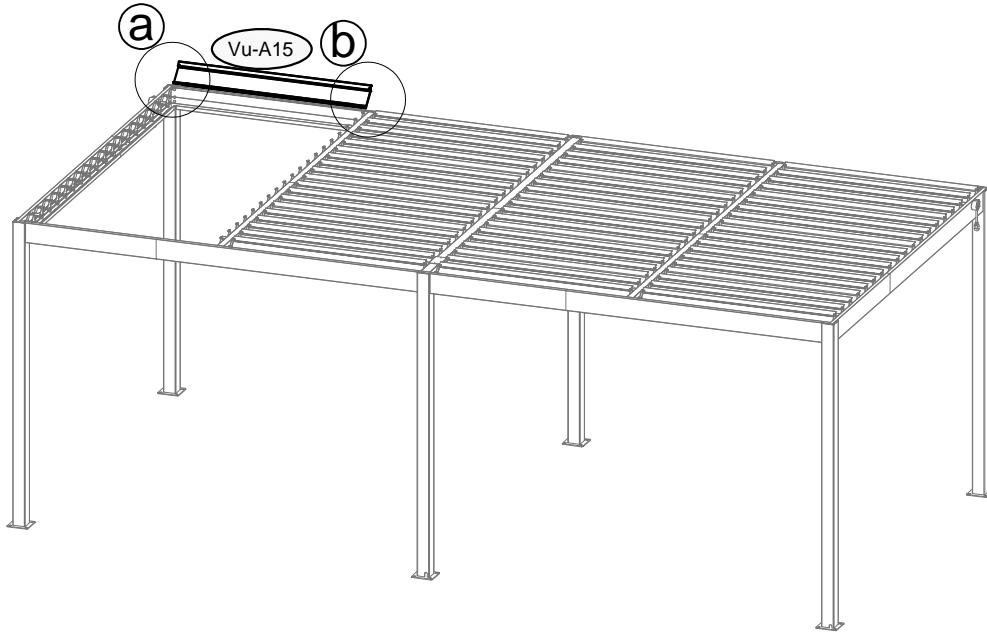

42



Vu-K42 x36

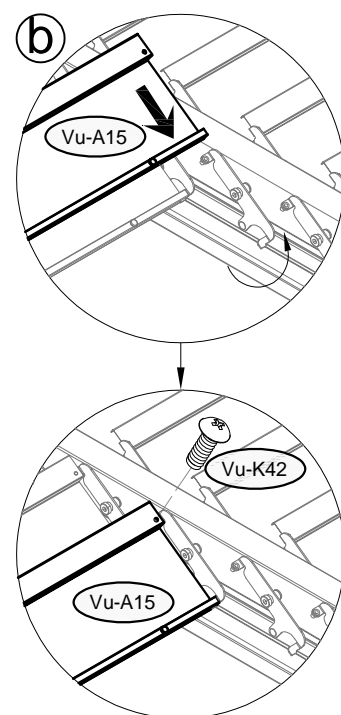
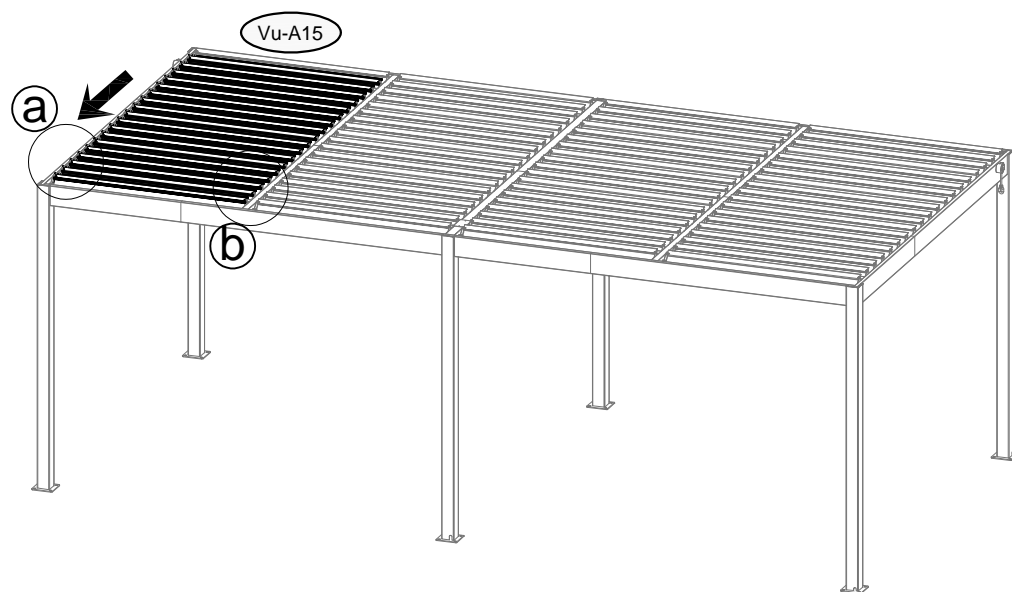
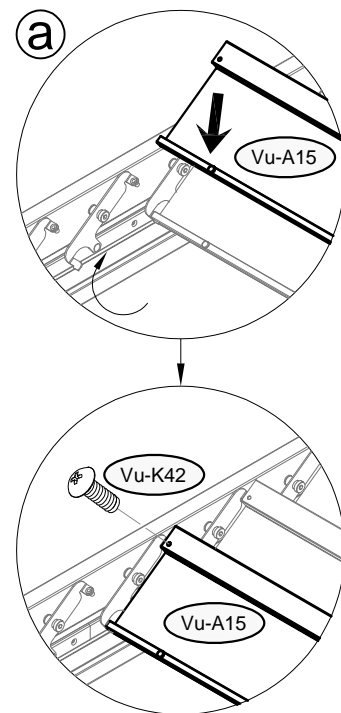
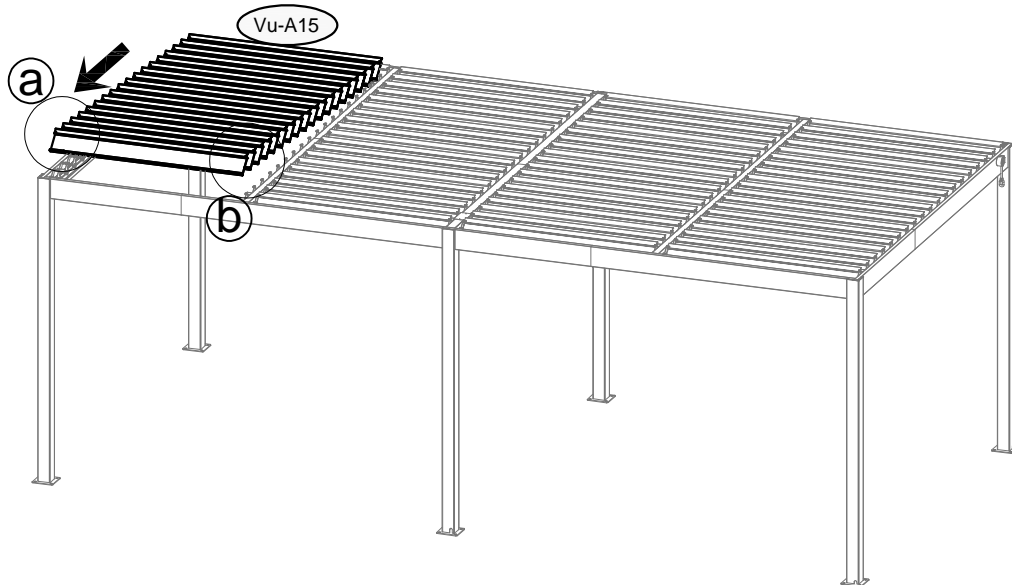

43	 Vu-A17 x8	 Vu-K37 x16	 Vu-K40 x16
-----------	--	---	---

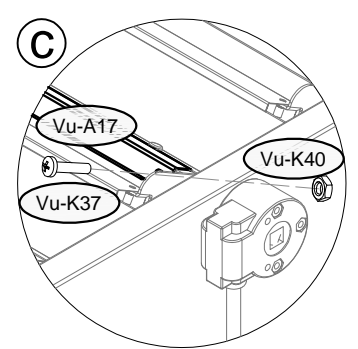
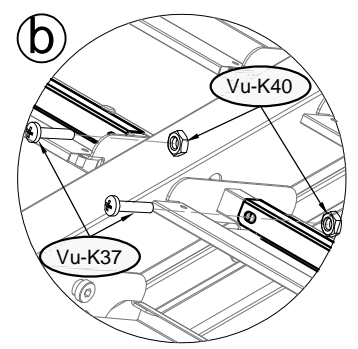
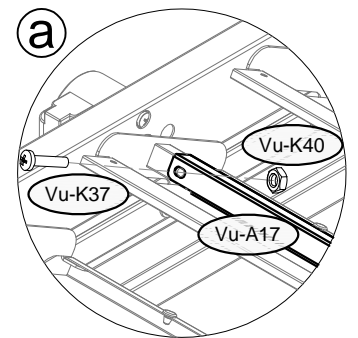
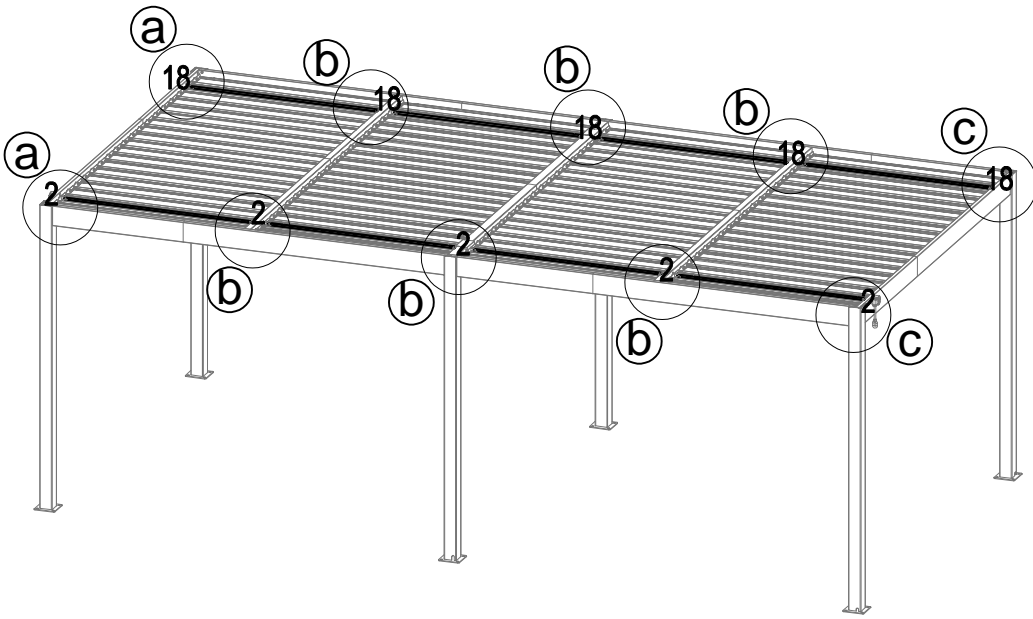
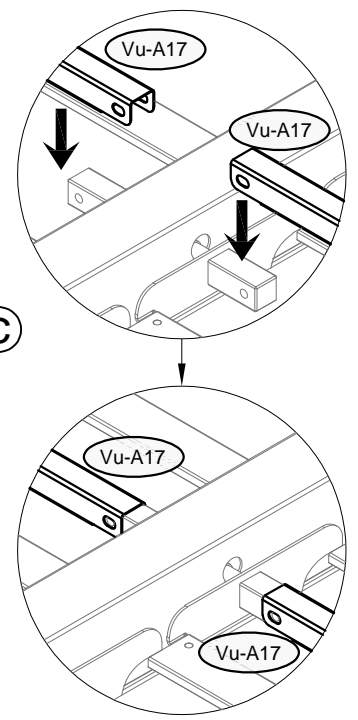
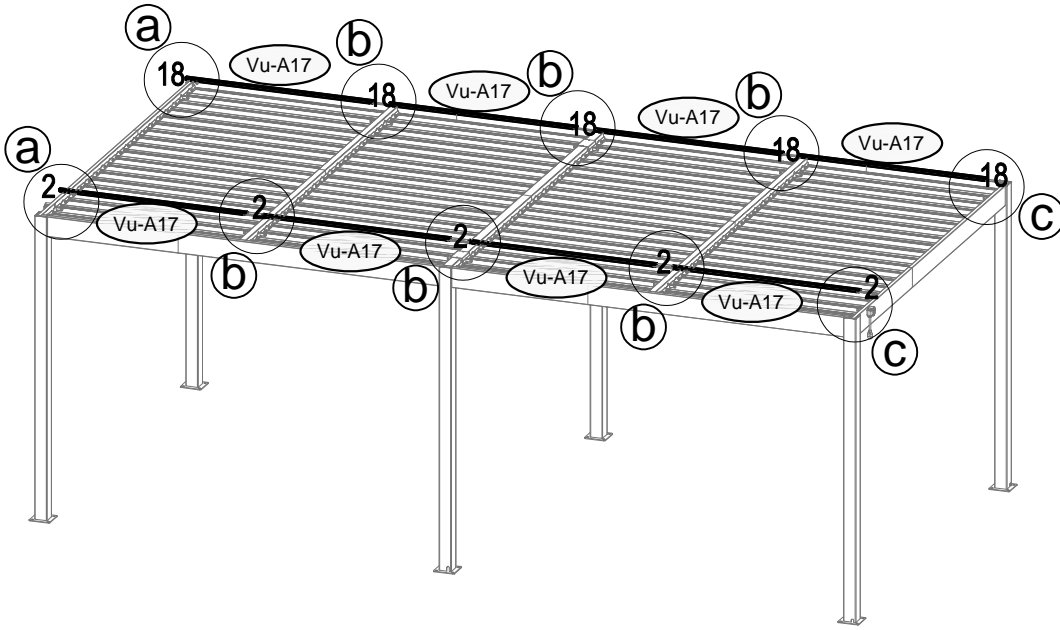

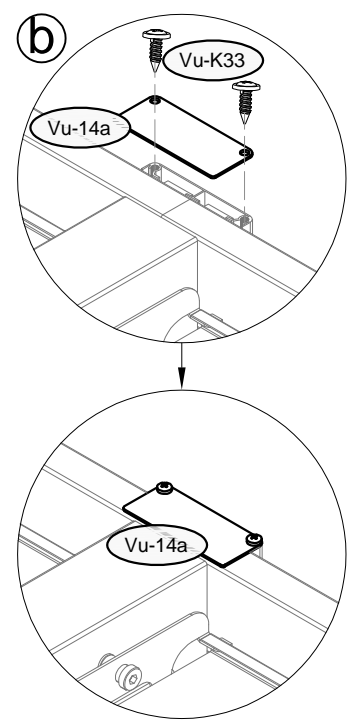
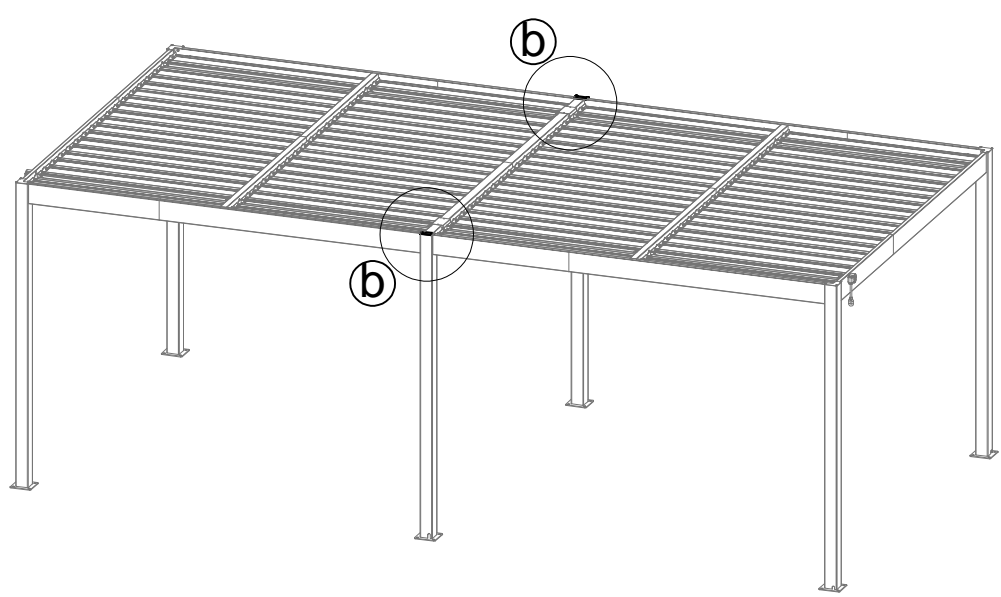
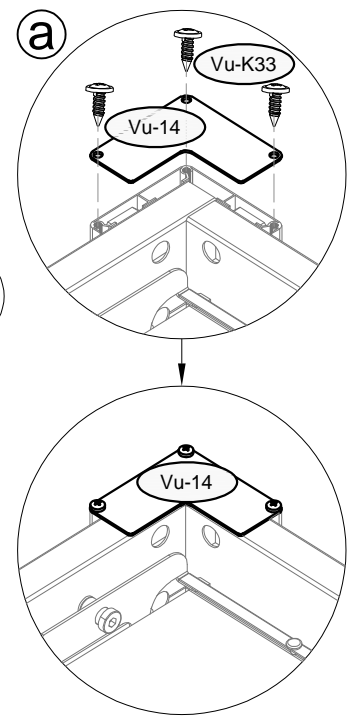
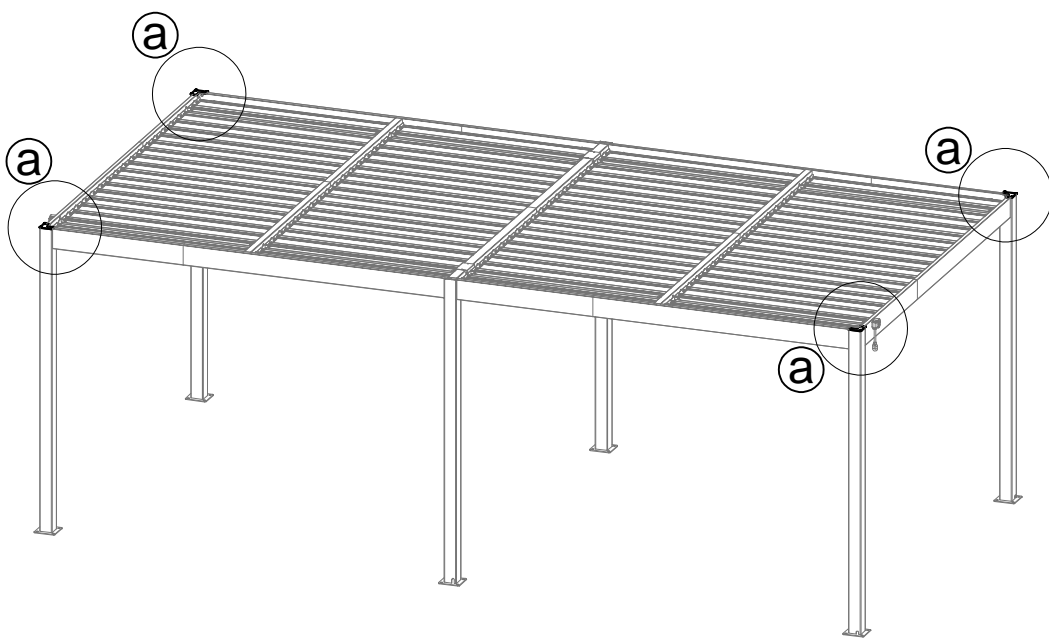

44	 Vu-14 x4	 Vu-14a x2	 Vu-K33 x16	
----	---	--	---	--



45

 Vu-23 x2

 Vu-K34 x8

 GY-16 x1

